

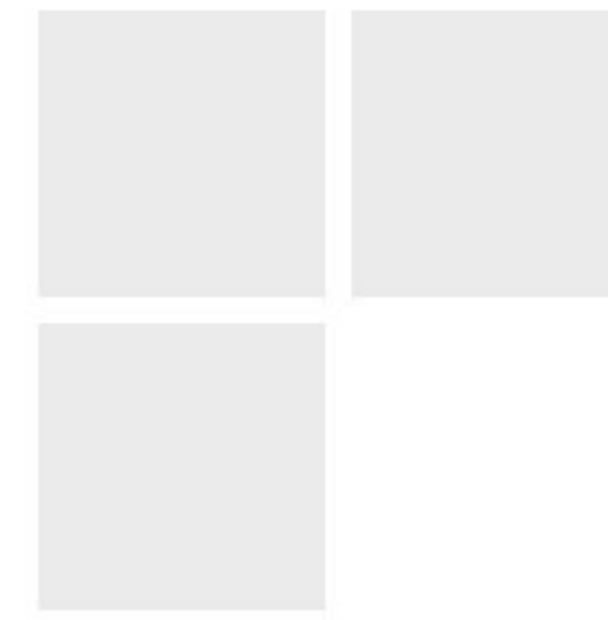

Königstein
konigstein.es



Welcome - 歡迎
Benvinguts - Bem
vinda | Bienvenue
Bine ati venit
Bienvenidos
Willkommen
Benvenuti



2.5T

-  1825-1960 mm
-  2500 kg
-  2766 mm
-  2032 mm
-  3 HP
-  (3 ~) 400/50V / Hz
(1 ~) 220/50V / Hz
-  2770*509*375mm
1920*1340*893mm
-  854 kg



KN3125PA

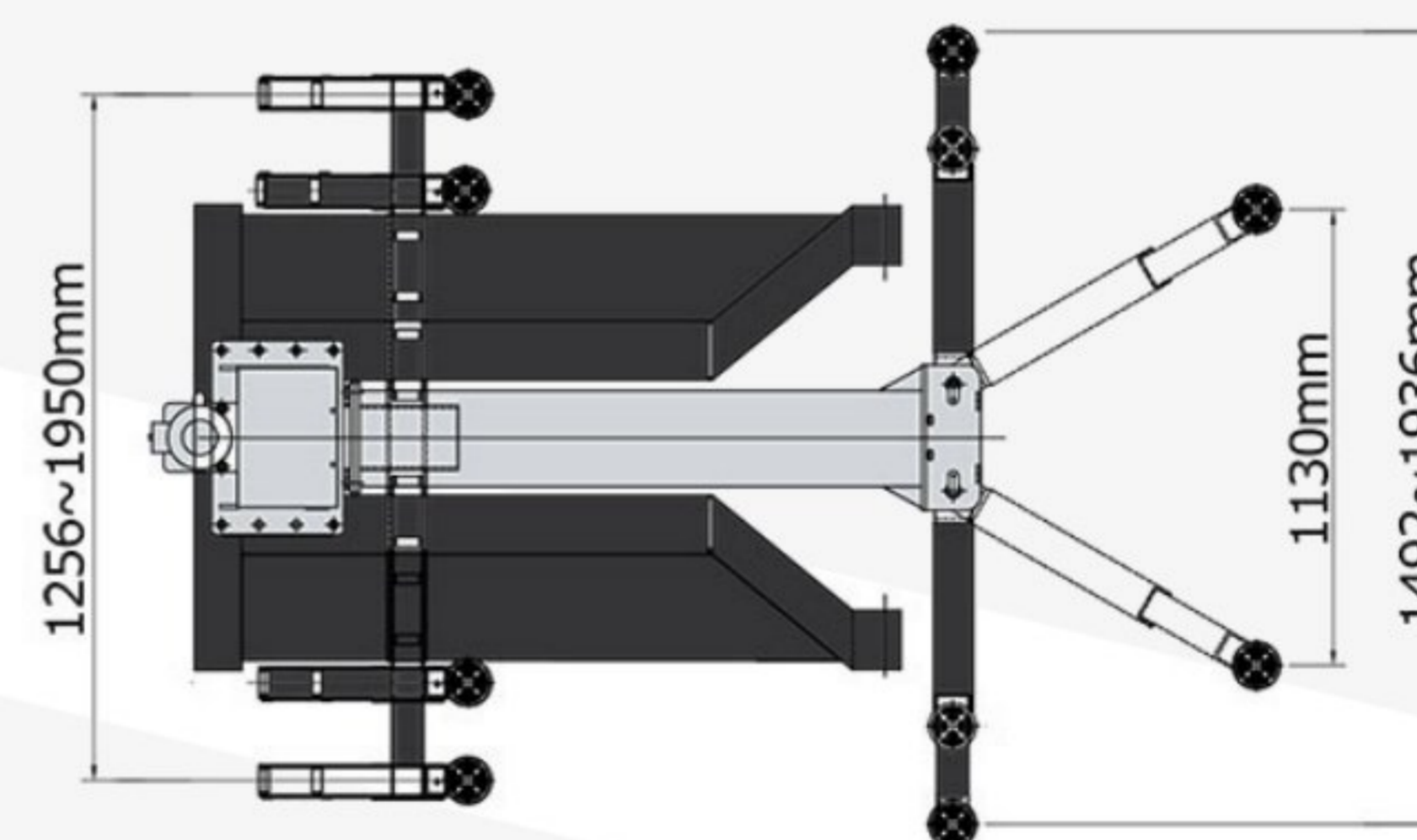
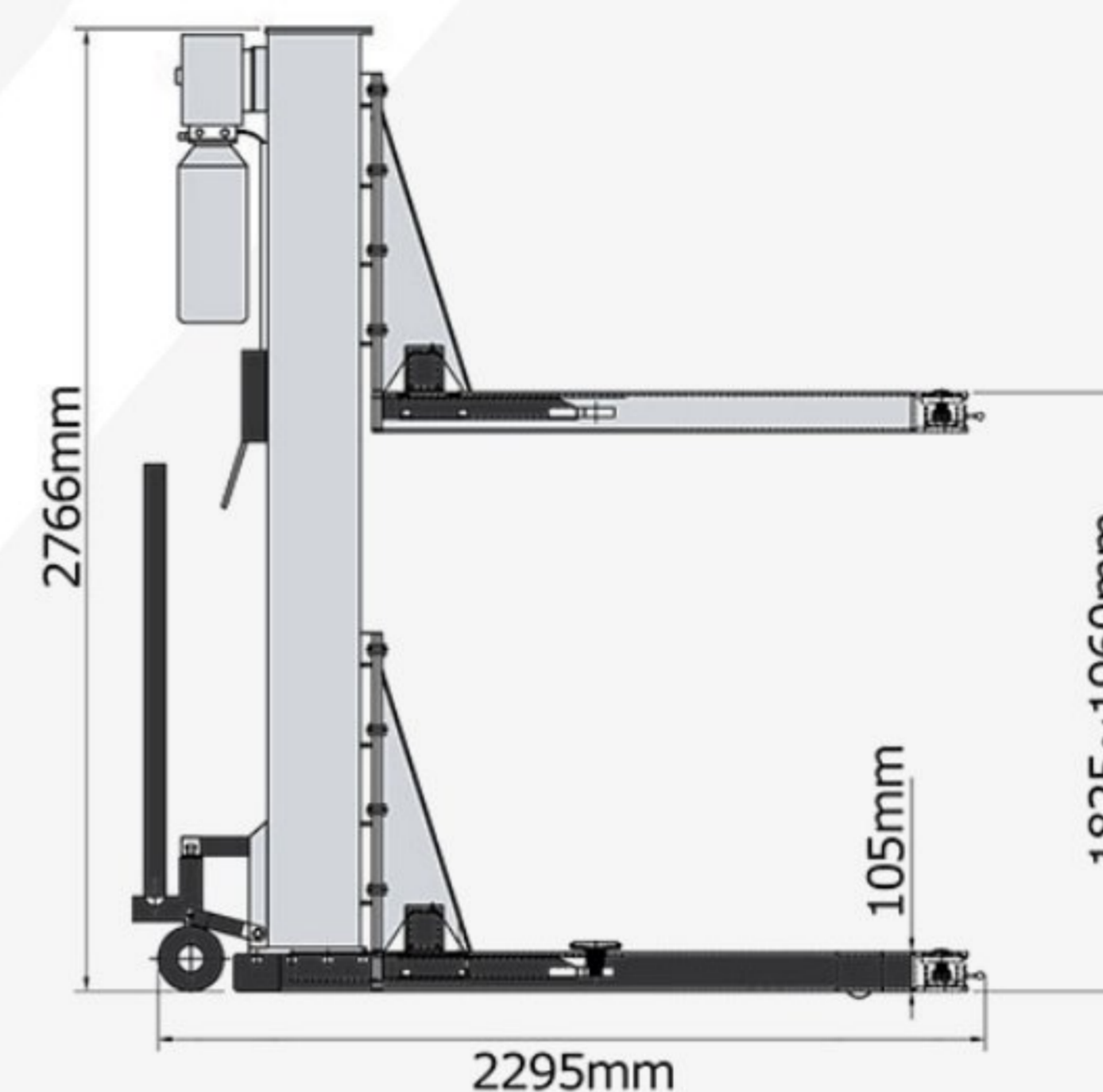

ELEVADOR 1 COLUMNA

- Subida y bajada automática a través del panel de control
- Tacos antifricción UHMW de poli y casquillo de bronce autolubricado
- Brazos de carga extraíbles con soportes de caucho graduables en altura.

PONT ÉLÉVATEUR 1 COLONNE

- Montée et descente automatiques via le panneau de commande
- Patins anti-friction en polyuréthane UHMW et bague en bronze autolubrifiante
- Bras de chargement amovibles avec supports en caoutchouc réglables en hauteur.

SINGLE COLUMN LIFT

- Removable loading arms with height-adjustable rubber supports.
- Mechanical safety systems to protect the hydraulic system, designed for a long service life.

SOLLEVATORE MONOCOLONNA

- Bracci di carico estensibili con supporti in gomma e regolabili in altezza.
- Sistemi di sicurezza meccanici ideati per proteggere il sistema idraulico, affinché abbia una lunga durata.

KN3125PA

Königstein

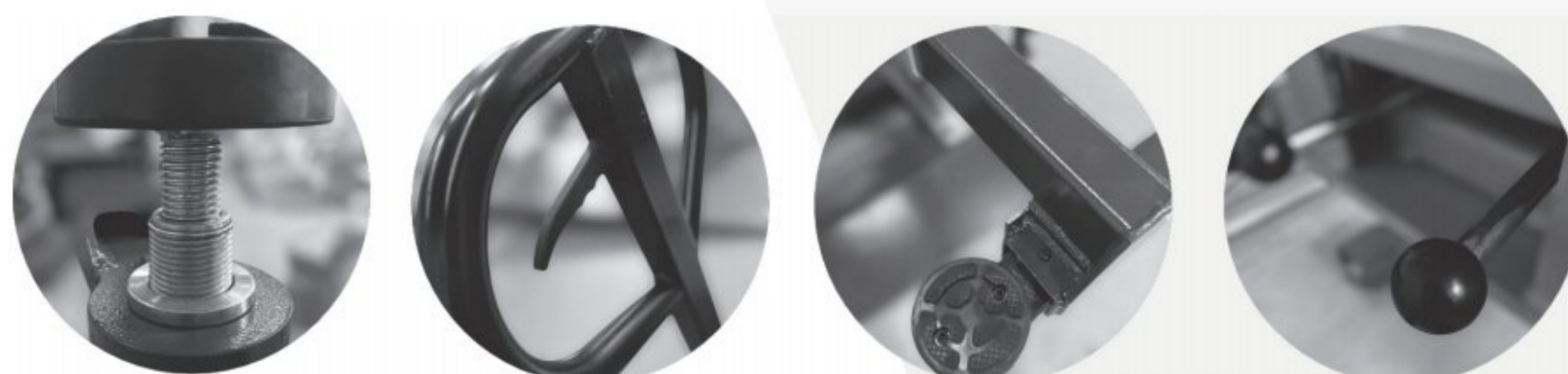

ES: Escanee el código para más información.

FR: Scannez le code pour plus d'informations.

EN: Scan the code for further information.

IT: Scansiona il codice per maggiori informazioni.



4T



1815-2000 mm



4000 kg

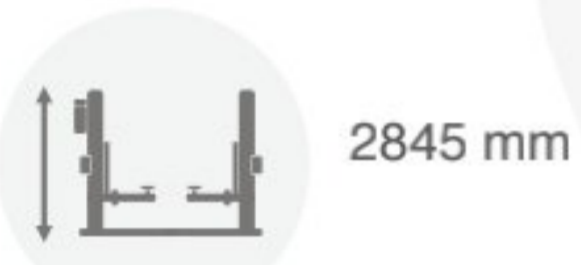

2845 mm

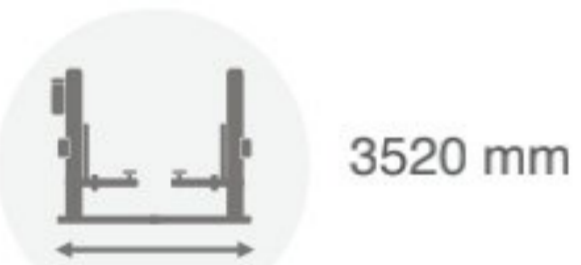

3520 mm

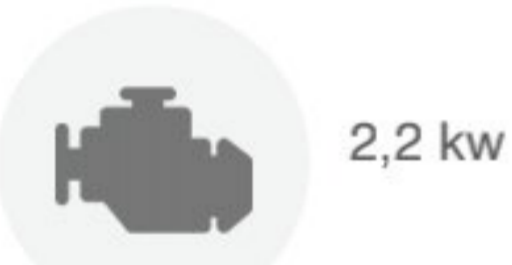

2,2 kw

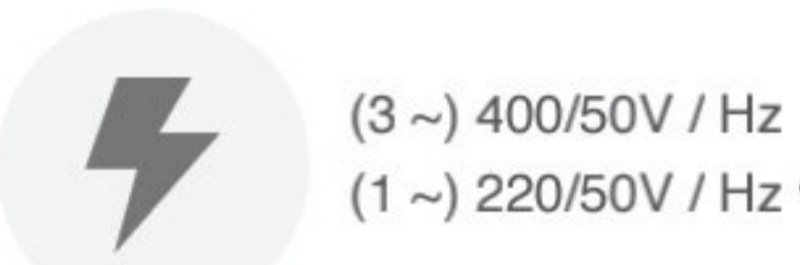

(3 ~) 400/50V / Hz
(1 ~) 220/50V / Hz



1 x 3 x 0.30 m







605 kg

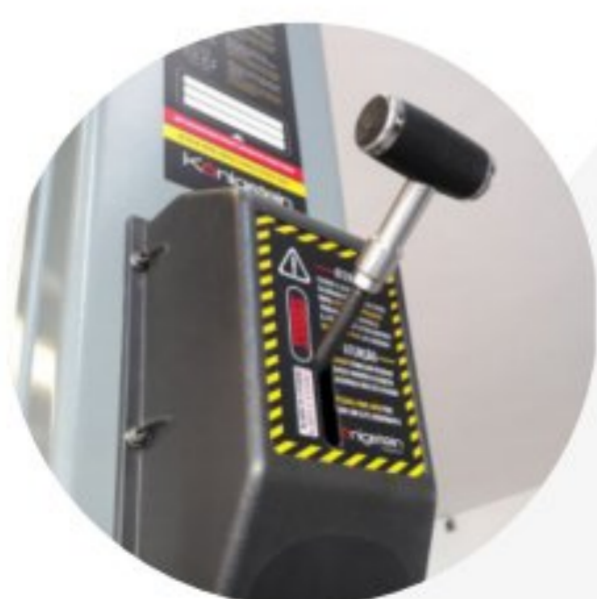

KN3240C
4T



SEGUROS MANUALES 
SÉCURITÉS MANUELLES 
MANUAL LOCKS 
SICUREZZE MANUALI 

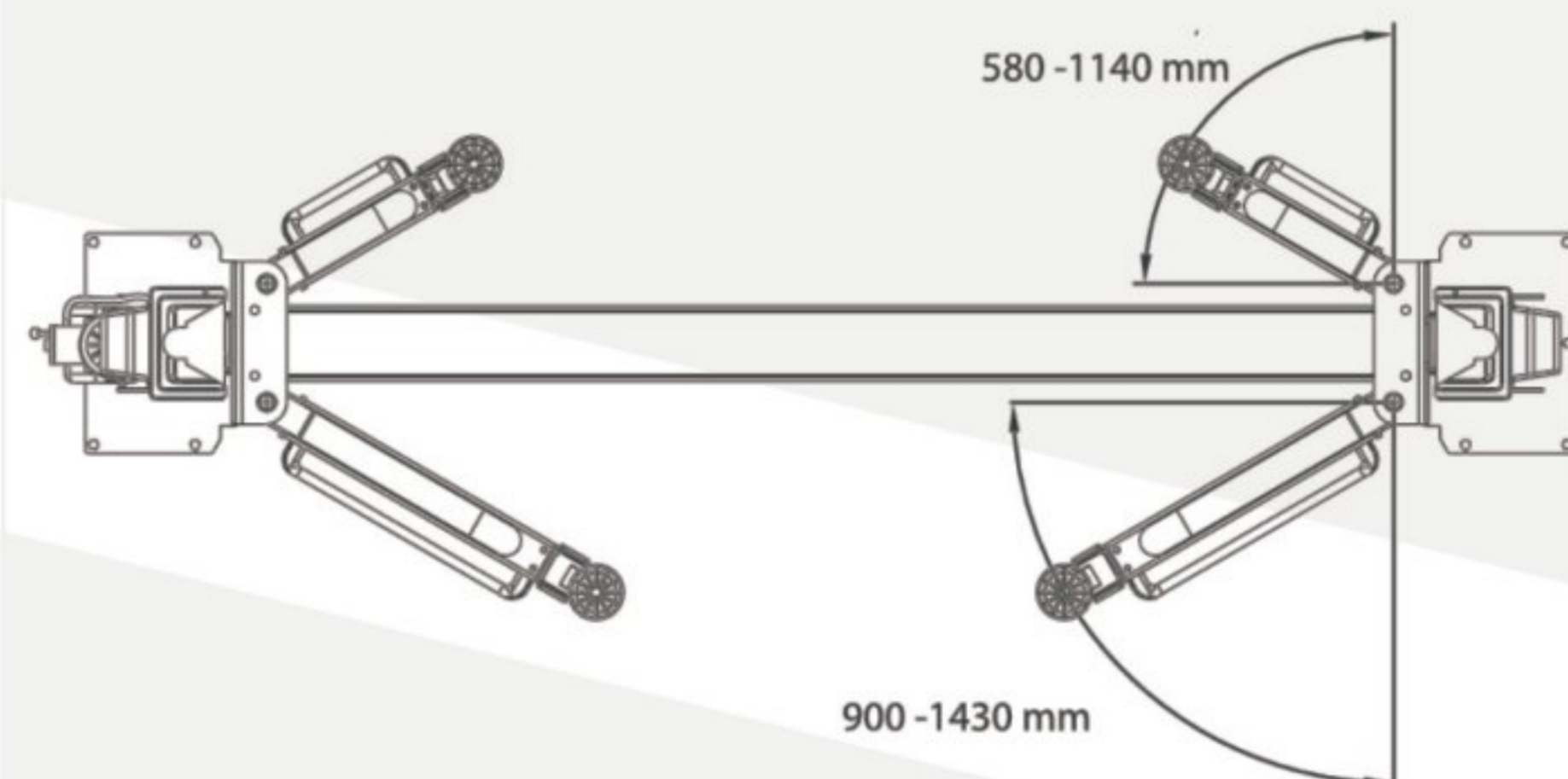
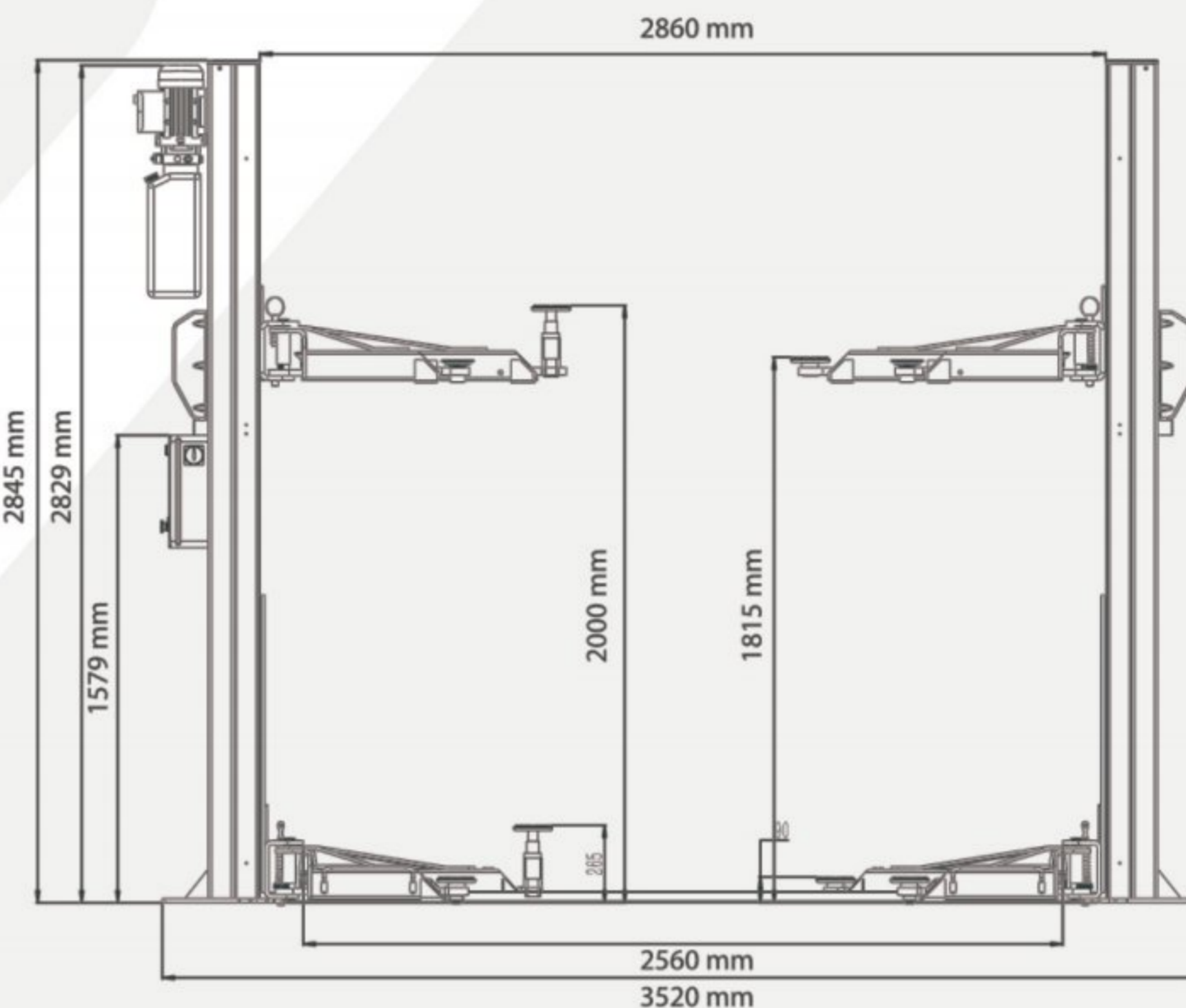

 **ELEVADOR 2 COLUMNA SEMIAUTOMÁTICO**

- Elevador hidráulico de dos columnas con los últimos avances, especialmente diseñados para talleres profesionales.
- Columnas fabricadas en acero de 5 mm y amplia distancia entre las mismas para facilitar el trabajo en el elevador.

 **PONT ÉLÉVATEUR 2 COLONNE SEMI AUTOMATIQUE**

- Elévateur hydraulique à deux colonnes équipé des toutes dernières technologies, spécialement conçu pour les ateliers professionnels.
- Colonnes en acier de 5 mm et large distance entre celles-ci pour faciliter le travail avec le pont élévateur.

 **SEMI AUTOMATIC 2 POST LIFT**

- Two post hydraulic lift with the latest advances, specially designed for professional workshops.
- Columns made of 5 mm steel and wide distance between them to facilitate work on the lift.

 **SOLLEVATORE A 2 COLONNE SEMI AUTOMATICO**

- Sollevatore idraulico a due colonne all'avanguardia, appositamente progettato per le officine professionali.
- Colonne in acciaio di 5 mm e con ampia distanza tra di loro per facilitare il lavoro con il sollevatore.



ES: Escanee el código para más información.

FR: Scannez le code pour plus d'informations.

EN: Scan the code for further information.

IT: Scansiona il codice per maggiori informazioni.



KN3240C

Königstein

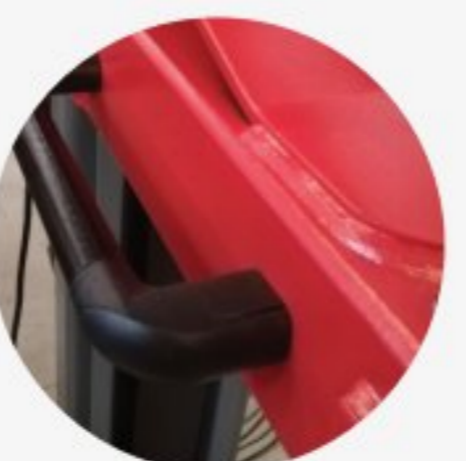
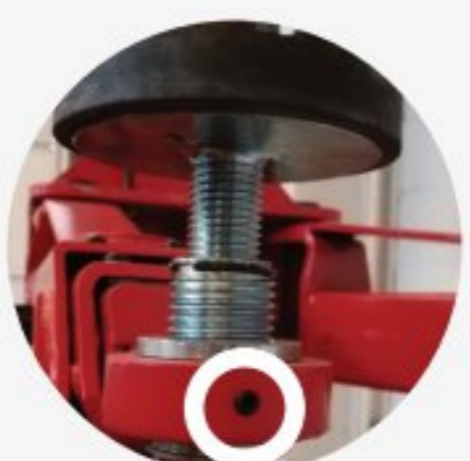

4T

4.5T



1815 mm



4000 kg / 4500 kg

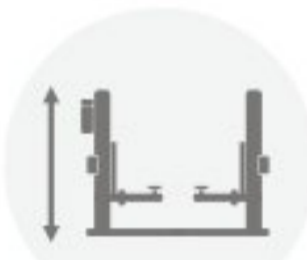

2845 mm



3520 mm



2,2 kw



(3 ~) 400/50V / Hz
(1 ~) 220/50V / Hz



1 x 3 x 0.30 m



610 kg / 630 kg



KN3240A



4.5 mm



KN3245A

5.5 mm



FABRICADO DE UNA SOLA PIEZA
PLEGADA ROBUSTA Y RESISTENTE



FAIT D'UNE SEULE PIÈCE PLIÉE, ROBUSTE
ET RÉSIDANTE



MADE IN ONE FOLDED RESSISTANT PIECE



REALIZZATO CON UN SOLO PEZZO
PIEGATO ROBUSTO E RESISTENTE.



Königstein

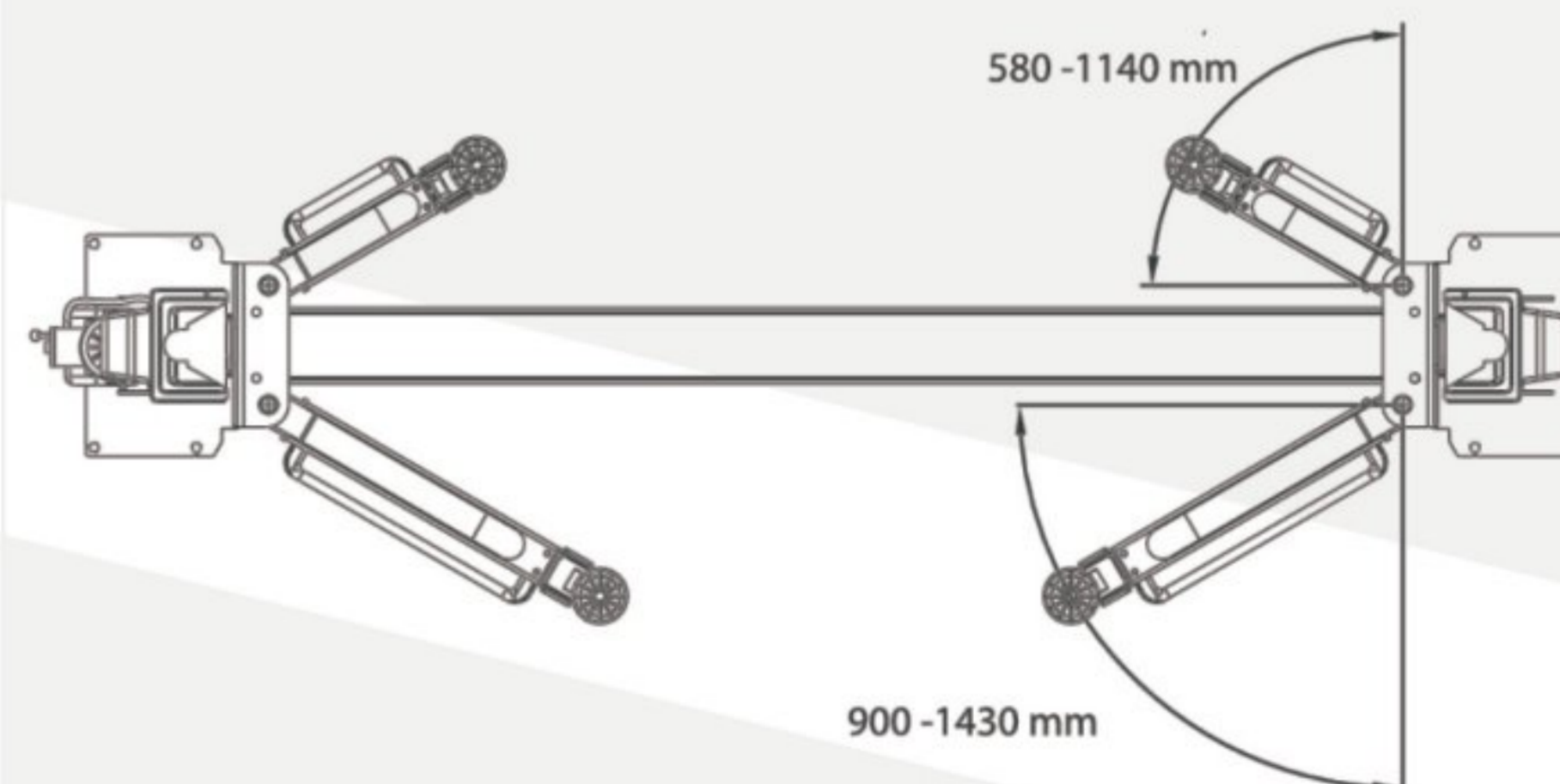
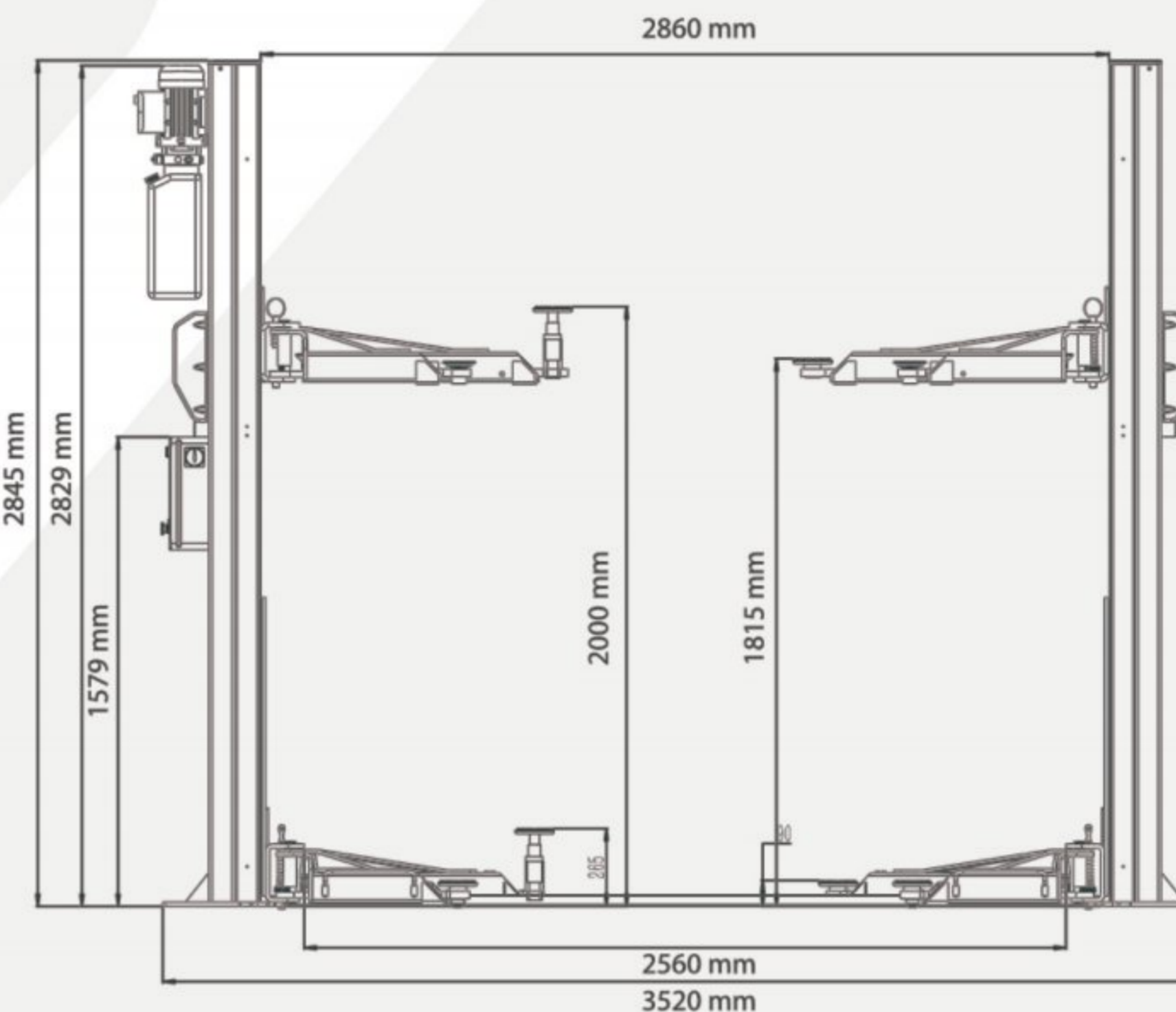
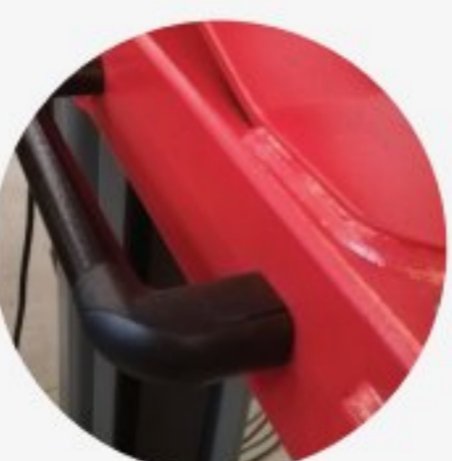
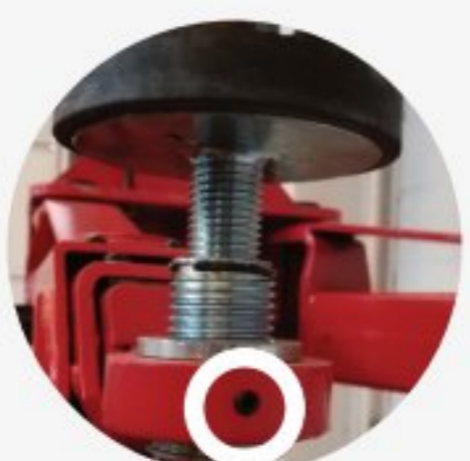

**ELEVADOR 2 COLUMNA
AUTOMÁTICO**

- Elevador hidráulico de dos columnas con los últimos avances, especialmente diseñados para talleres profesionales.

- Columnas fabricadas en acero de 5 mm y amplia distancia entre las mismas para facilitar el trabajo en el elevador.

**PONT ÉLÉVATEUR 2
COLONNE
AUTOMATIQUE**

- Elévateur hydraulique à deux colonnes équipé des toutes dernières technologies, spécialement conçu pour les ateliers professionnels.

- Colonnes en acier de 5 mm et large distance entre celles-ci pour faciliter le travail avec le pont élévateur.

AUTOMATIC 2 POST LIFT

- Two post hydraulic lift with the latest advances, specially designed for professional workshops.

- Columns made of 5 mm steel and wide distance between them to facilitate work on the lift.

**SOLLEVATORE A 2 COLONNE
AUTOMATICO**

- Sollevatore idraulico a due colonne all'avanguardia, appositamente progettato per le officine professionali.

- Colonne in acciaio di 5 mm e con ampia distanza tra di loro per facilitare il lavoro con il sollevatore.



ES: Escanee el código para más información.

EN: Scan the code for further information.

FR: Scannez le code pour plus d'informations.

IT: Scansiona il codice per maggiori informazioni.



4T



1850 mm



4000 kg / 4500 kg

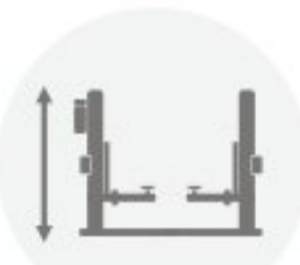

2845 mm



3400 mm



2,2 kw



(3 ~) 400/50V / Hz
(1 ~) 220/50V / Hz



1 x 3 x 0.30 m



610 kg



KN3240A
BASIC



5 mm



FABRICADO DE UNA SOLA PIEZA
PLEGADA ROBUSTA Y RESISTENTE

FAIT D'UNE SEULE PIÈCE PLIÉE, ROBUSTE
ET RÉSIDANTE

MADE IN ONE FOLDED RESSISTANT PIECE

REALIZZATO CON UN SOLO PEZZO
PIEGATO ROBUSTO E RESISTENTE.

KN3240A BASIC

Königstein

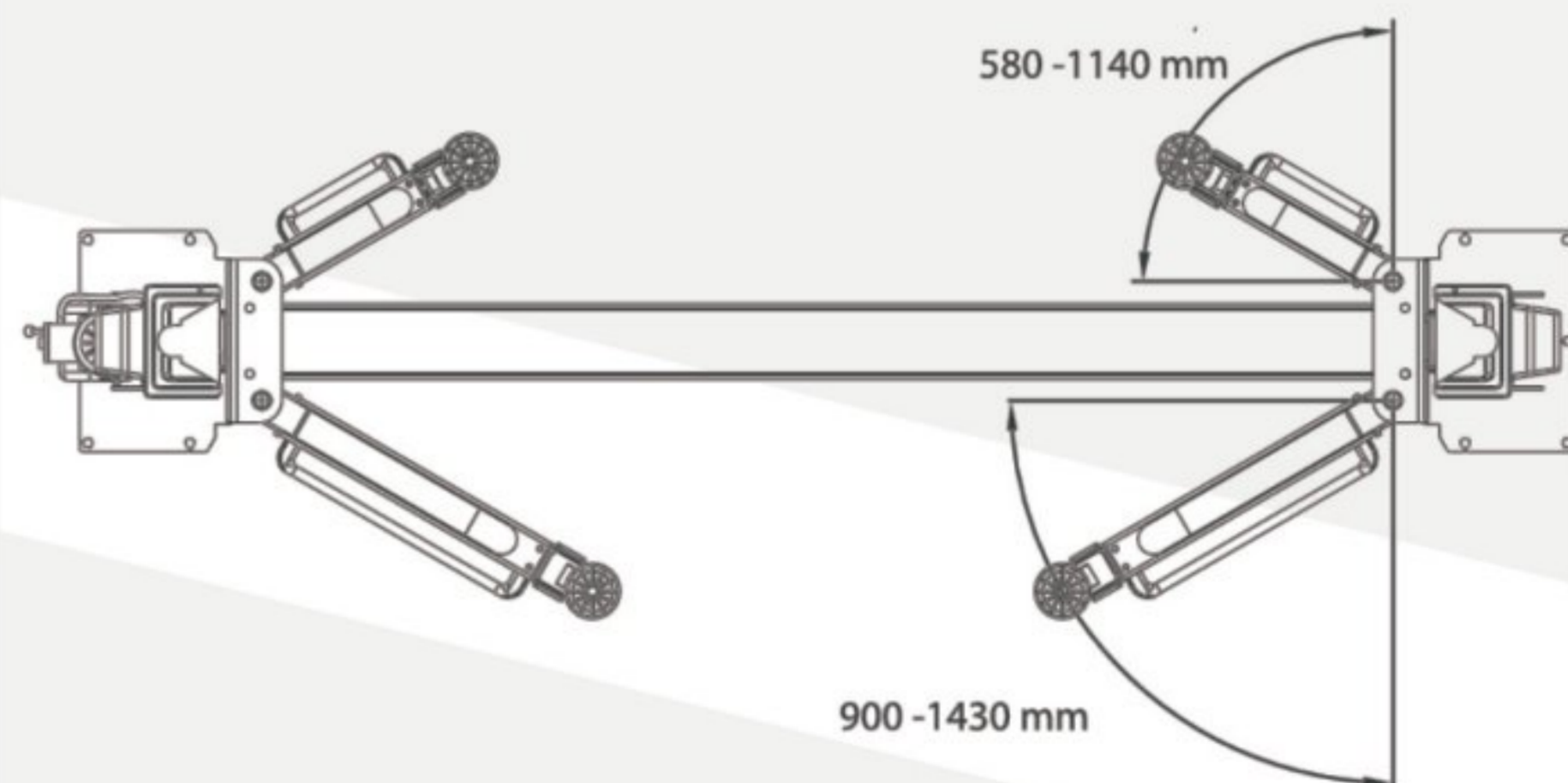
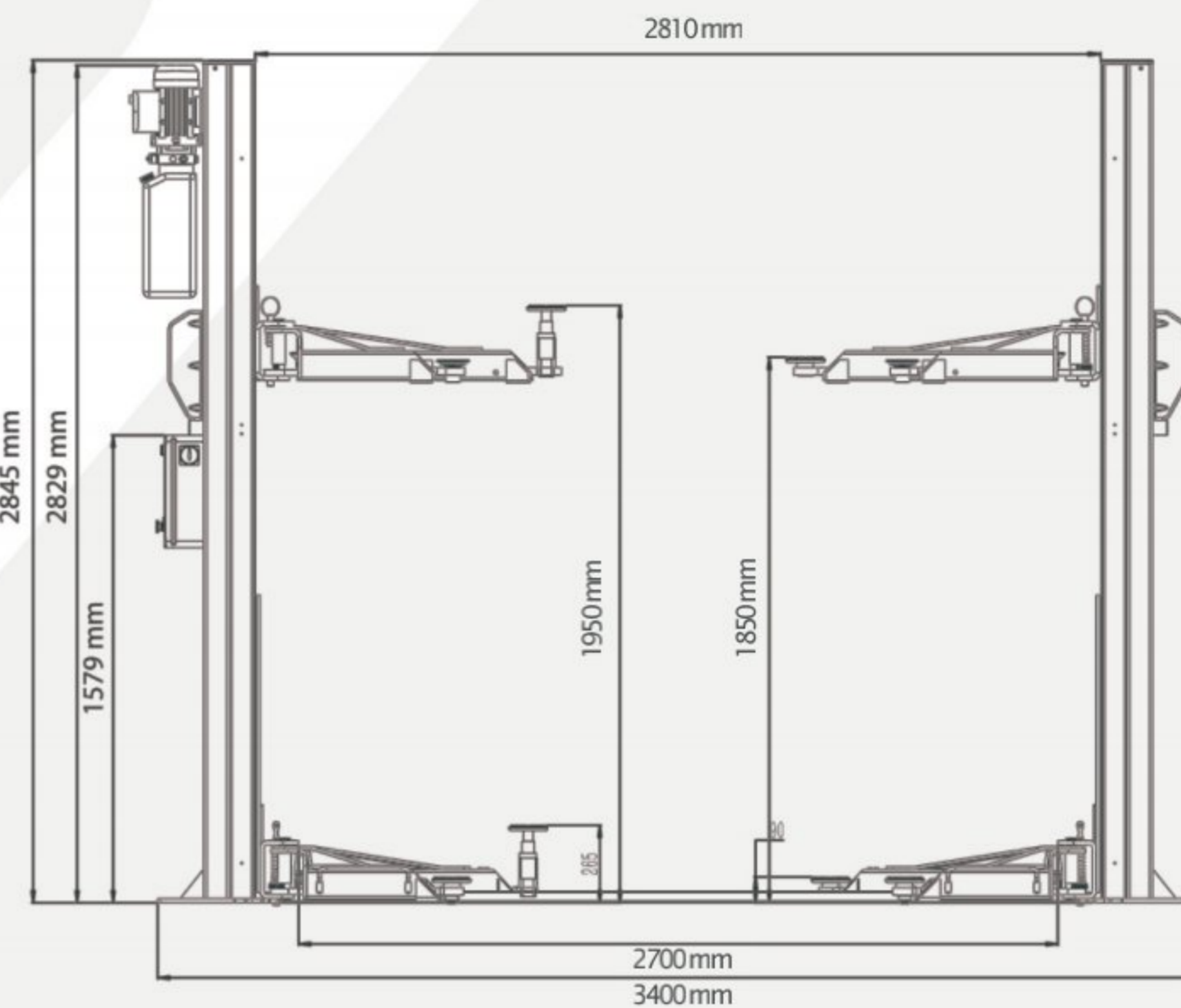
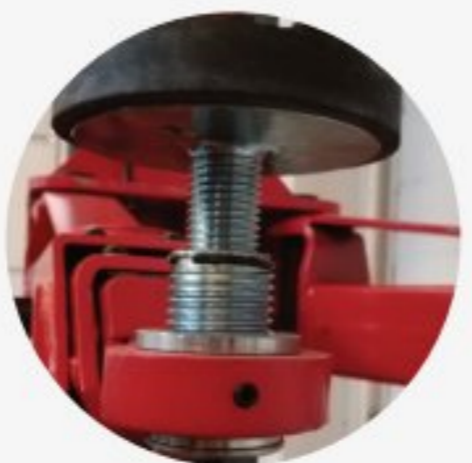

**ELEVADOR 2 COLUMNA
AUTOMÁTICO**

- Elevador hidráulico de dos columnas con los últimos avances, especialmente diseñados para talleres profesionales.

- Columnas fabricadas en acero de 5 mm y amplia distancia entre las mismas para facilitar el trabajo en el elevador.

**PONT ÉLÉVATEUR 2
COLONNE
AUTOMATIQUE**

- Elévateur hydraulique à deux colonnes équipé des toutes dernières technologies, spécialement conçu pour les ateliers professionnels.

- Colonnes en acier de 5 mm et large distance entre celles-ci pour faciliter le travail avec le pont élévateur.

AUTOMATIC 2 POST LIFT

- Two post hydraulic lift with the latest advances, specially designed for professional workshops.

- Columns made of 5 mm steel and wide distance between them to facilitate work on the lift.

**SOLLEVATORE A 2 COLONNE
AUTOMATICO**

- Sollevatore idraulico a due colonne all'avanguardia, appositamente progettato per le officine professionali.

- Colonne in acciaio di 5 mm e con ampia distanza tra di loro per facilitare il lavoro con il sollevatore.



ES: Escanee el código para más información.

FR: Scannez le code pour plus d'informations.

EN: Scan the code for further information.

IT: Scansiona il codice per maggiori informazioni.



Königstein

4.5T

KN3245A PRO

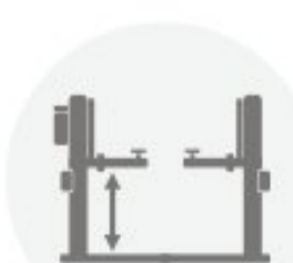

130/1835 mm



4500 kg

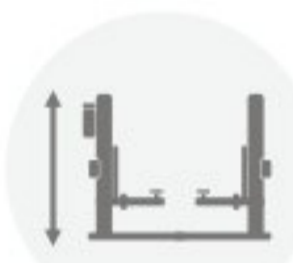

2865 mm



3340 mm



2,2 kw



(3 ~) 400/50V / Hz
(1 ~) 220/50V / Hz

Base en H no incluida

Soncle H non inclus

Base H frame non included

Base non inclusa

Königstein



700 kg



2850*450*780mm
860*260*340



FABRICADO DE UNA SOLA PIEZA PLEGADA ROBUSTA Y RESISTENTE

FAIT D'UNE SEULE PIÈCE PLIÉE, ROBUSTE ET RÉSISTANTE

MADE IN ONE FOLDED RESISTANT PIECE

REALIZZATO CON UN SOLO PEZZO PIEGATO ROBUSTO E RESISTENTE.

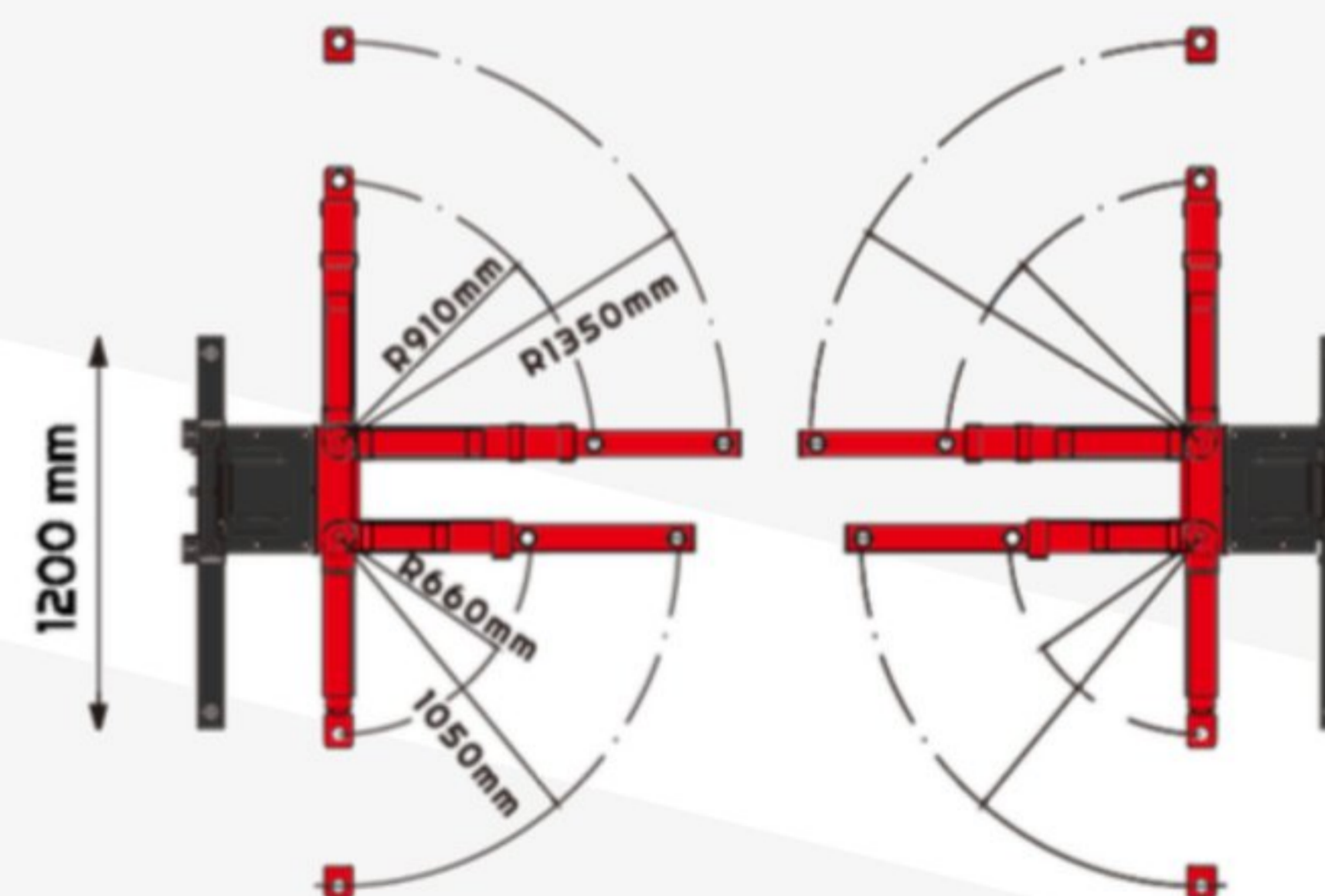
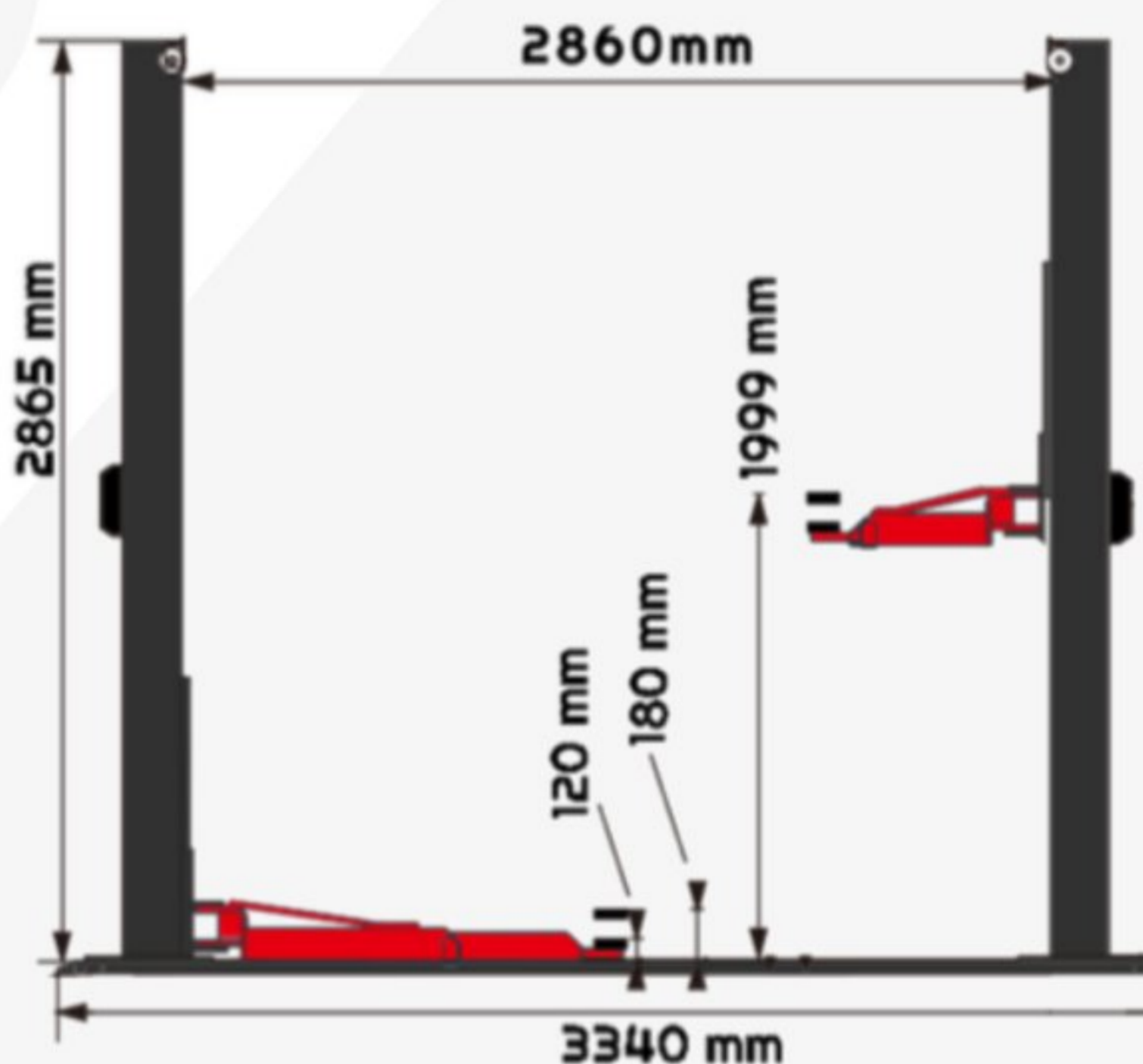

ELEVADOR 2 COLUMNA AUTOMÁTICO

- Elevador hidráulico de dos columnas con los últimos avances, especialmente diseñados para talleres profesionales.

- Columnas fabricadas en acero de 5 mm y amplia distancia entre las mismas para facilitar el trabajo en el elevador.

PONT ÉLÉVATEUR 2 COLONNE AUTOMATIQUE

- Elévateur hydraulique à deux colonnes équipé des toutes dernières technologies, spécialement conçu pour les ateliers professionnels.

- Colonnes en acier de 5 mm et large distance entre celles-ci pour faciliter le travail avec le pont élévateur.

AUTOMATIC 2 POST LIFT

- Two post hydraulic lift with the latest advances, specially designed for professional workshops.

- Columns made of 5 mm steel and wide distance between them to facilitate work on the lift.

SOLLEVATORE A 2 COLONNE AUTOMATICO

- Sollevatore idraulico a due colonne all'avanguardia, appositamente progettato per le officine professionali.

- Colonne in acciaio di 5 mm e con ampia distanza tra di loro per facilitare il lavoro con il sollevatore.



ES: Escanee el código para más información.

FR: Scannez le code pour plus d'informations.

EN: Scan the code for further information.

IT: Scansiona il codice per maggiori informazioni.



4.5T



1820 mm



4000 kg / 4500 kg



4500 mm



3445 mm



2,2 kw



(3 ~) 400/50V / Hz
(1 ~) 220/50V / Hz



1.05 x 3 x 0.50 m



720 kg



KN3245PSX



5.5 mm



Cuadro eléctrico con 2 diferenciales incorporados y un puente rectificador de gran capacidad.

Electrical panel with 2 built-in differentials and a high capacity rectifier bridge.

Panneau électrique avec 2 différentiels intégrés et un pont redresseur de grande capacité.

Quadro elettrico con 2 differenziali incorporati e un ponte raddrizzatore di grande

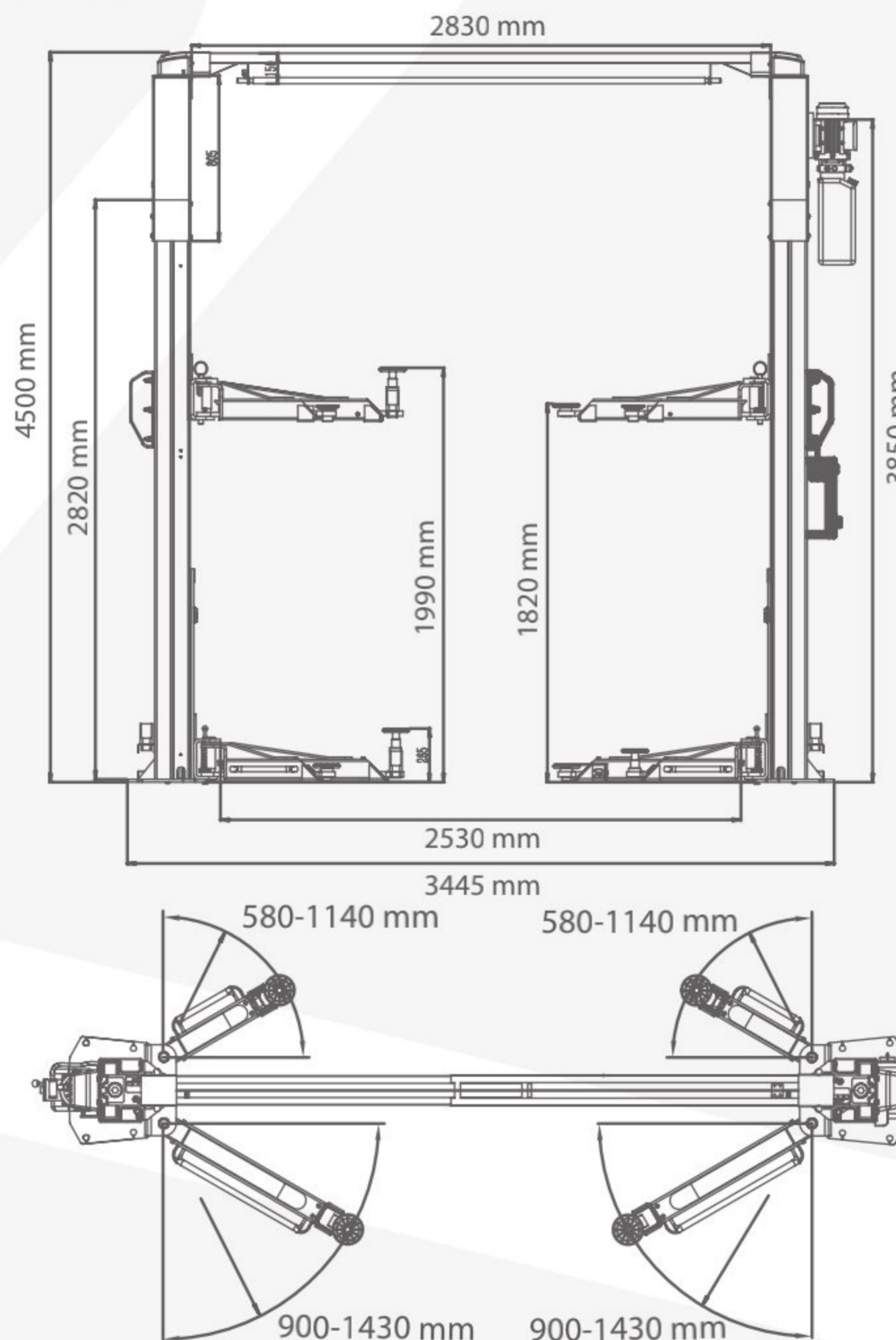

ES: Escanee el código para más información.

FR: Scannez le code pour plus d'informations.

EN: Scan the code for further information.

IT: Scansiona il codice per maggiori informazioni.



ELEVADOR 2 COLUMNAS AUTOMÁTICO CON PUENTE SUPERIOR

- Elevador hidráulico de dos columnas con los últimos avances, especialmente diseñados para talleres profesionales.
- Columnas fabricadas en acero de 5 mm y amplia distancia entre las mismas para facilitar el trabajo en el elevador.

PONT ÉLÉVATEUR 2 COLONNES AUTOMATIQUE AVEC TRAVERSE SUPÉRIEURE

- Elévateur hydraulique à deux colonnes équipé des toutes dernières technologies, spécialement conçu pour les ateliers professionnels.
- Colonnes en acier de 5 mm et large distance entre celles-ci pour faciliter le travail avec le pont élévateur.

AUTOMATIC 2 POST LIFT

- Two post hydraulic lift with the latest advances, specially designed for professional workshops.
- Columns made of 5 mm steel and wide distance between them to facilitate work on the lift.

SOLLEVATORE A 2 COLONNES AUTOMATICO CON TRAVERSA SUPERIORE

- Sollevatore idraulico a due colonne all'avanguardia, appositamente progettato per le officine professionali.
- Colonne in acciaio di 5 mm e con ampia distanza tra di loro per facilitare il lavoro con il sollevatore.

KN3245PSX

Königstein

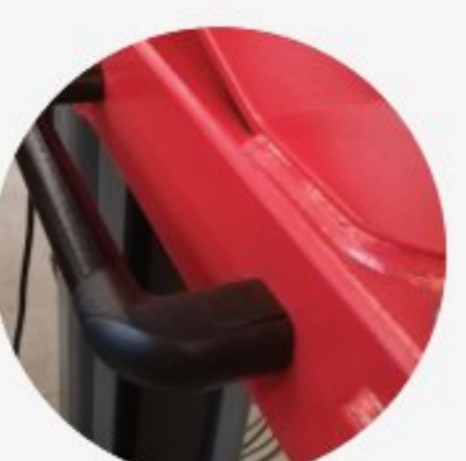
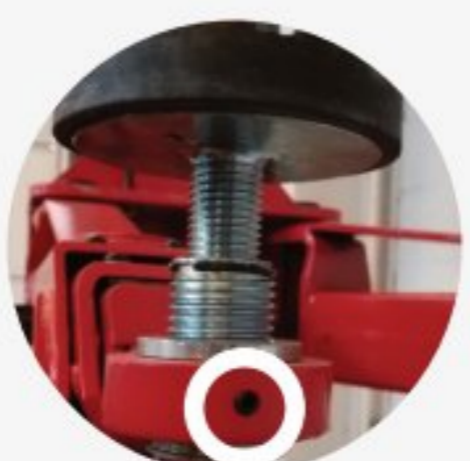
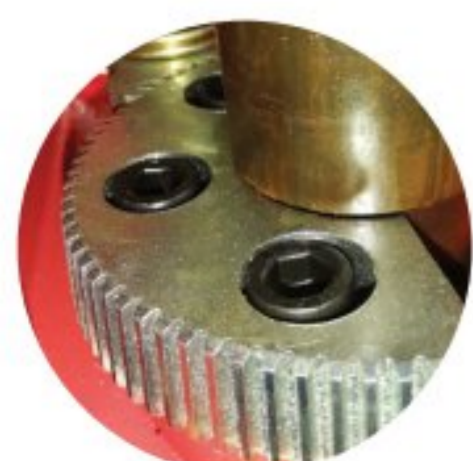

NOTA: Las imágenes mostradas tienen el propósito de representar el producto solamente y pueden variar dependiendo del modelo y stock

4T

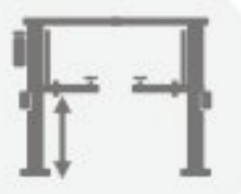
-  1990
-  4000 kg
-  3950 mm
-  3460 mm
-  3,0 kw
-  (3 ~) 400V / 50Hz
(1 ~) 220V / 50Hz
-  0.90 x 3.85 x 0.55m
0.76 x 0.33 x 0.23m
0.40 x 0.40 x 0.25m
-  700 kg



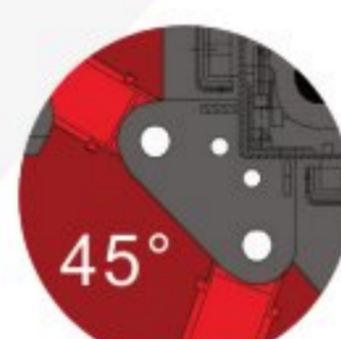

KN3240PSXA



 Cuadro electrico con 2 diferenciales incorporados y un puente rectificador de gran capacidad.

 Panneau électrique avec 2 différentiels intégrés et un pont

 Electrical panel with 2 built-in differentials and a high capacity rectifier bridge.

 Quadro elettrico con 2 differenziali incorporati e un ponte raddrizzatore di grande

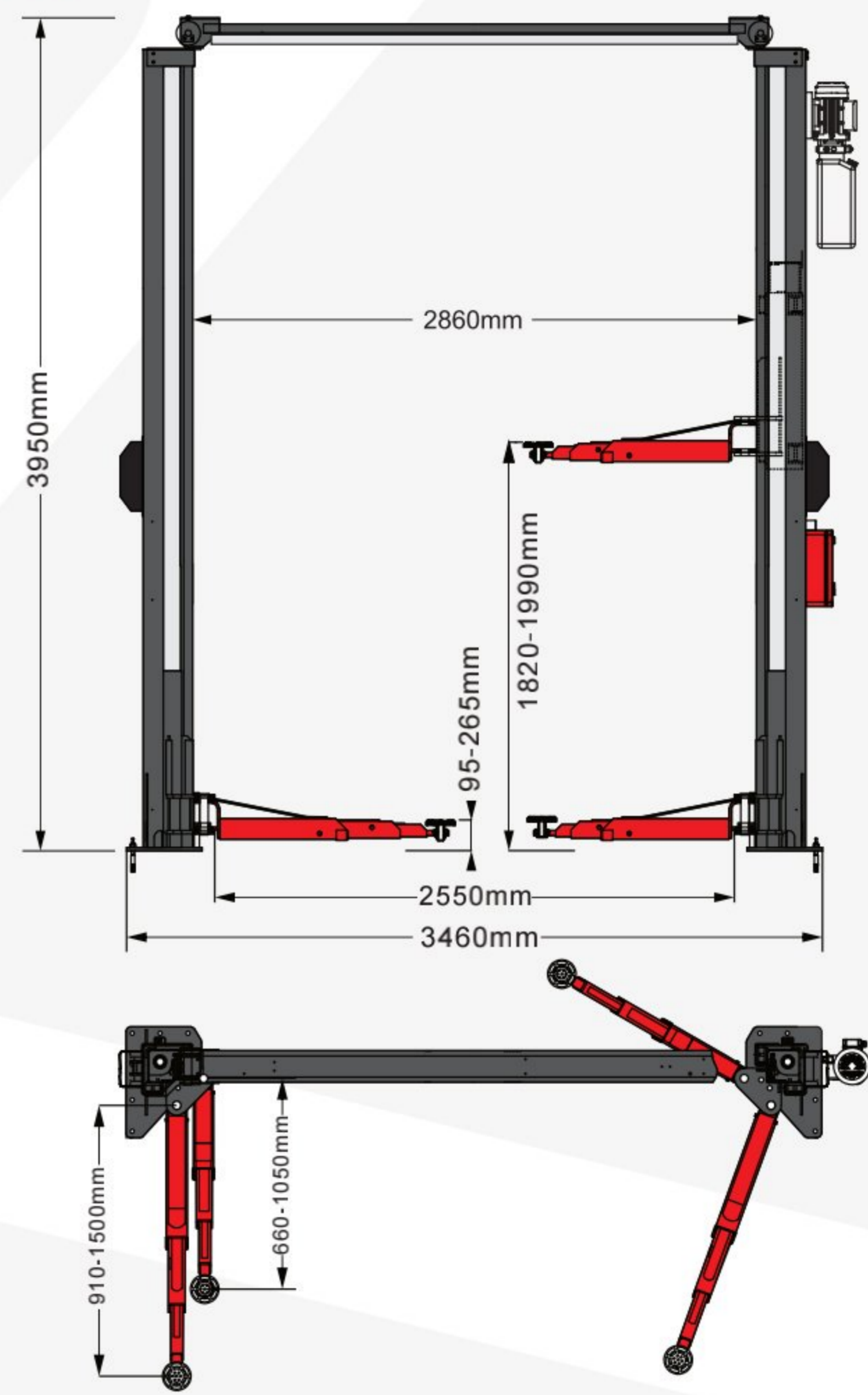

 **ELEVADOR 2 COLUMNAS AUTOMÁTICO CON PUENTE SUPERIOR Y BRAZOS ASIMÉTRICOS**

- Columnas fabricadas en acero de 5 mm y amplia distancia entre las mismas para facilitar el trabajo en el elevador.

 **PONT ÉLÉVATEUR 2 COLONNES AUTOMATIQUE AVEC TRAVERSE SUPÉRIEURE**

- Elévateur hydraulique à deux colonnes équipé des toutes dernières technologies, spécialement conçu pour les ateliers professionnels.

- Colonnes en acier de 5 mm et large distance entre celles-ci pour faciliter le travail avec le pont élévateur.

AUTOMATIC 2 POST LIFT

 - Two post hydraulic lift with the latest advances, specially designed for professional workshops.

- Columns made of 5 mm steel and wide distance between them to facilitate work on the lift.

 **SOLLEVATORE A 2 COLONNES AUTOMATICO CON TRAVERSA SUPERIORE**

- Sollevatore idraulico a due colonne all'avanguardia, appositamente progettato per le officine professionali.

- Colonne in acciaio di 5 mm e con ampia distanza tra di loro per facilitare il lavoro con il sollevatore.

KN3240PSXA

Königstein

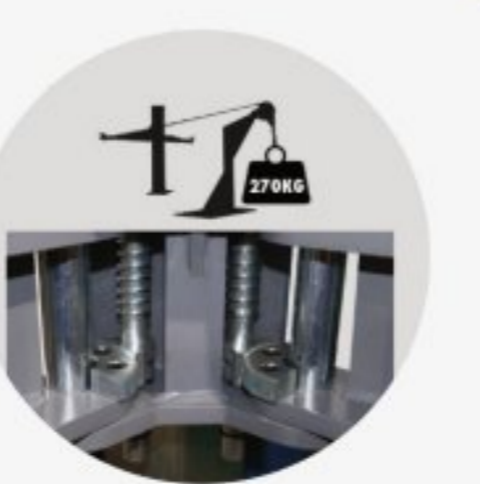
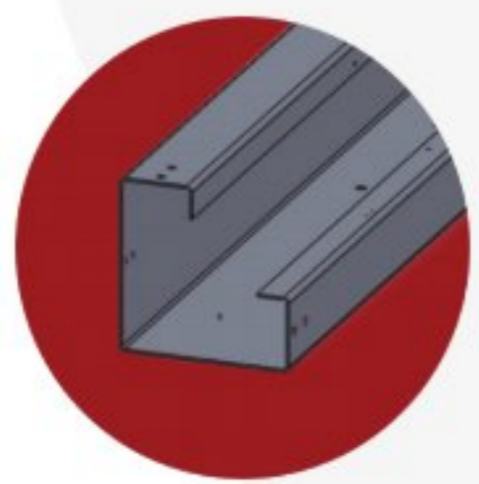

ES: Escanee el código para más información.

FR: Scannez le code pour plus d'informations.

EN: Scan the code for further information.

IT: Scansiona il codice per maggiori informazioni.



3.5T

-  105 / 1945 mm
-  3500 kg
-  1945 mm
-  2105 mm
-  2,2 kw
-  (3 ~) 400/50V / Hz
- 
-  880 kg

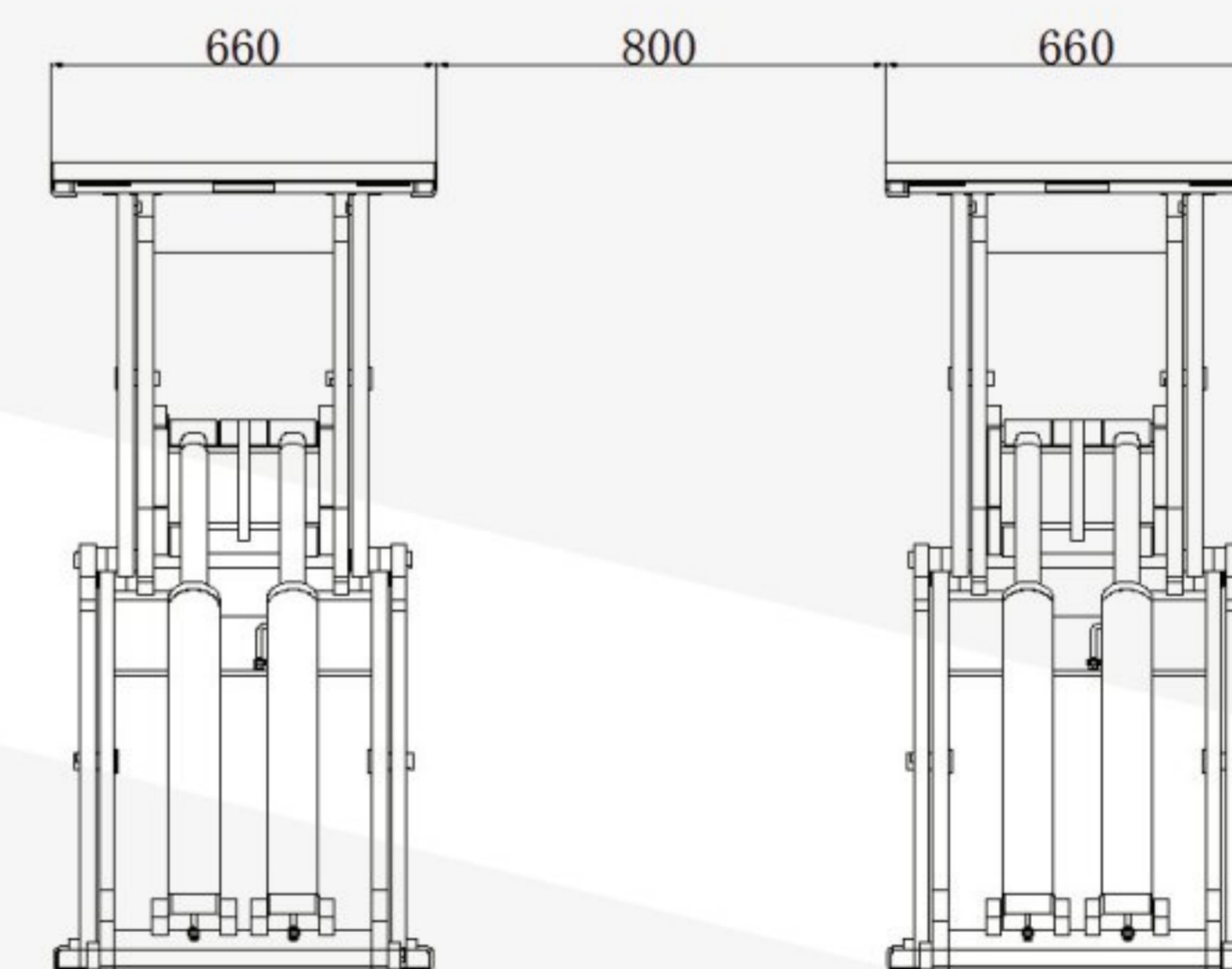
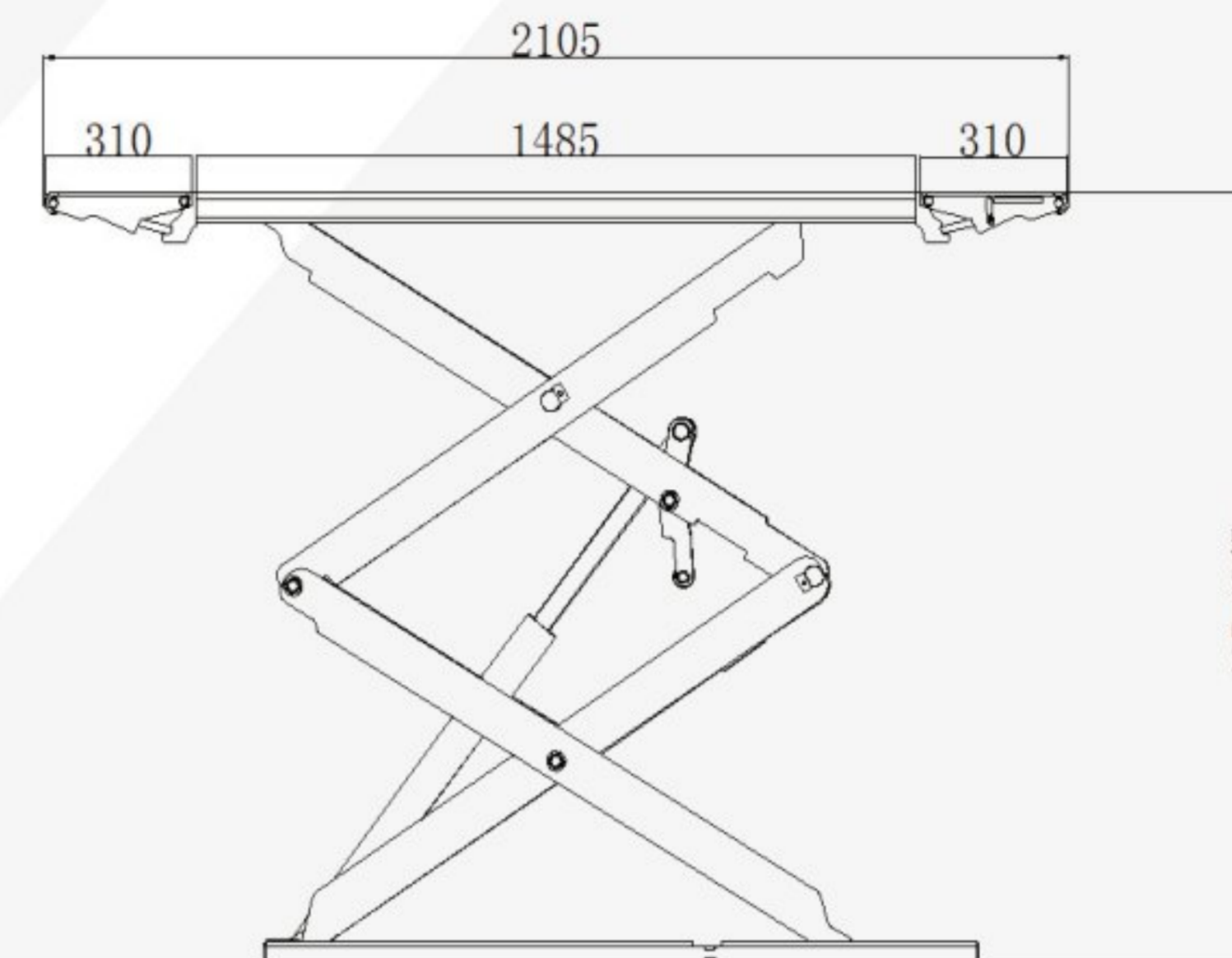

-  Rampas extensibles hasta 2105 mm.
-  Rampes extensibles à 2105 mm.
-  Extendable ramps on both sides up to 2105 mm.
-  Rampe estensibili fino 2105 mm.

ELEVADOR DE TIJERAS DE SUPERFICIE

- Fotocélula de nivelación que bloquea en caso de una descompensación accidental de la plataforma
- Sistema de seguridad hidráulico con cilindros cruzados y válvula paracaídas incorporada, **sin necesidad de aire comprimido** para su funcionamiento.

PONT ÉLÉVATEUR HYDRAULIQUE DE CISEAUX EN SURFACE

- Photocellule de niveau qui se bloque en cas de décompression accidentelle de la plateforme.
- Système de sécurité hydraulique avec cylindres croisés et une soupape anti chute intégrée, **sans nécessité d'air comprimé** pour le fonctionnement.

SURFACE SCISSOR LIF

- Leveling photocell that blocks in case of accidental decompensation of the platform.
- Hydraulic safety system with crossed cylinders and incorporated parachute valve, **without the need for compressed air** to operate

SOLLEVATORE A FORBICE SOPRA SUOLO

- Fotocellula di livellamento che blocca la macchina in caso di sbilanciamento accidentale della piattaforma.
- Sistema di sicurezza idraulico con cilindri trasversali e valvola paracadute inclusa, **non necessita di aria compressa** per il suo funzionamento

KN3635SX

Königstein



ES: Escanee el código para más información.

FR: Scannez le code pour plus d'informations.

EN: Scan the code for further information.

IT: Scansiona il codice per maggiori informazioni.



Königstein

3.6T

105 / 1880 mm

3600 kg

1880mm

2090mm

3,0 kw

(3 ~) 400V/50Hz

1610*674*520mm
440*360*960
440*400*250

975 kg

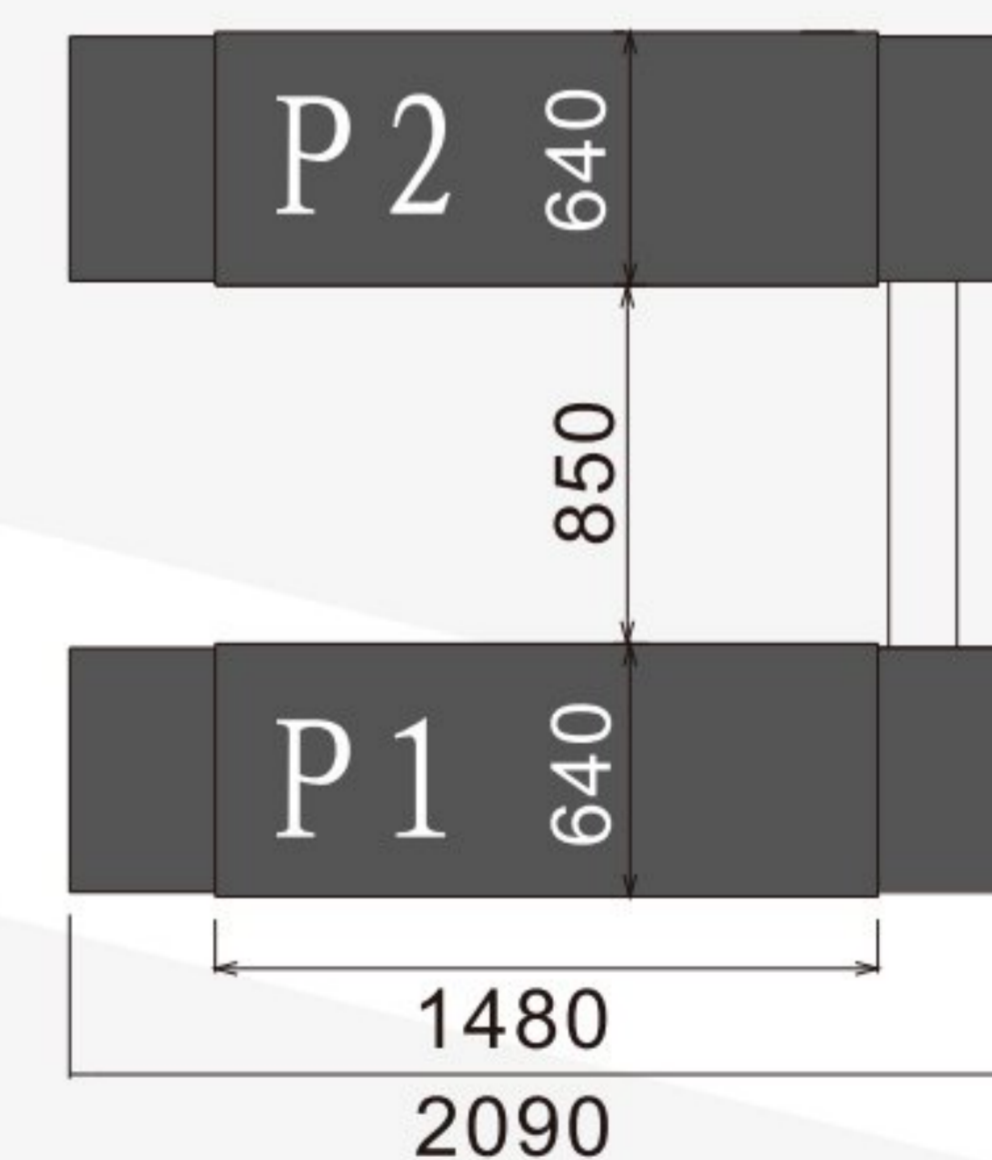
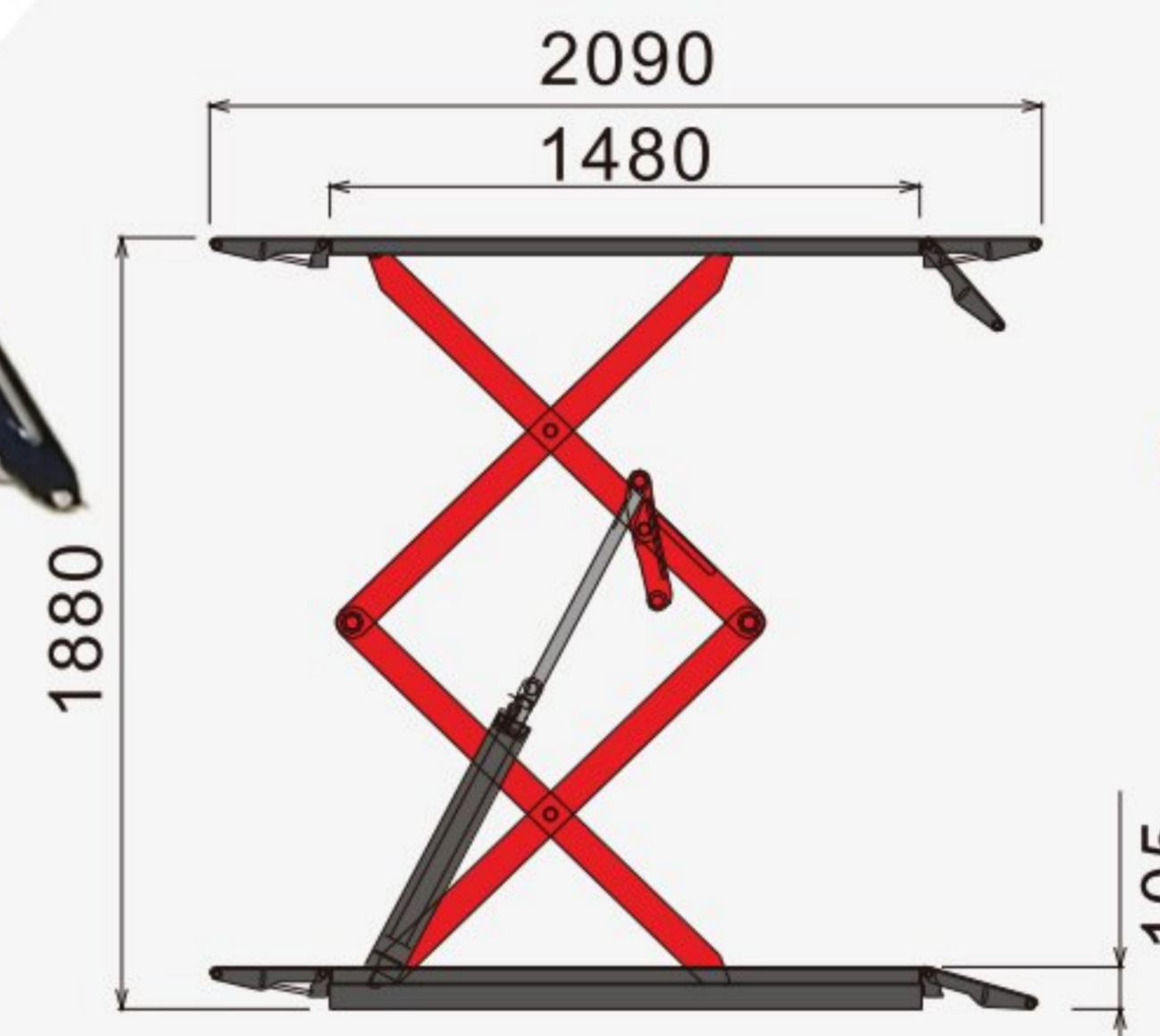

- Rampas extensibles hasta 2090 mm.
- Rampes extensibles à 2090 mm.
- Extendable ramps on both sides up to 2090 mm.
- Rampe estensibili fino 2090 mm.

ELEVADOR DE TIJERAS DE SUPERFICIE

- Fococélula de nivelación que bloquea en caso de una descompensación accidental de la plataforma
- Sistema de seguridad hidráulico con cilindros cruzados y válvula paracaídas incorporada, **sin necesidad de aire comprimido** para su funcionamiento.

PONT ÉLEVATEUR HYDRAULIQUE DE CISEAUX EN SURFACE

- Photocellule de niveau qui se bloque en cas de décompression accidentelle de la plateforme.
- Système de sécurité hydraulique avec cylindres croisés et une soupape anti chute intégrée, **sans nécessité d'air comprimé** pour le fonctionnement.

SURFACE SCISSOR LIF

- Leveling photocell that blocks in case of accidental decompensation of the platform.
- Hydraulic safety system with crossed cylinders and incorporated parachute valve, **without the need for compressed air** to operate

SOLLEVATORE A FORBICE SOPRA SUOLO

- Fococellula di livellamento che blocca la macchina in caso di sbilanciamento accidentale della piattaforma.
- Sistema di sicurezza idraulico con cilindri trasversali e valvola paracadute inclusa, **non necessita di aria compressa** per il suo funzionamento

KN3636SX

Königstein

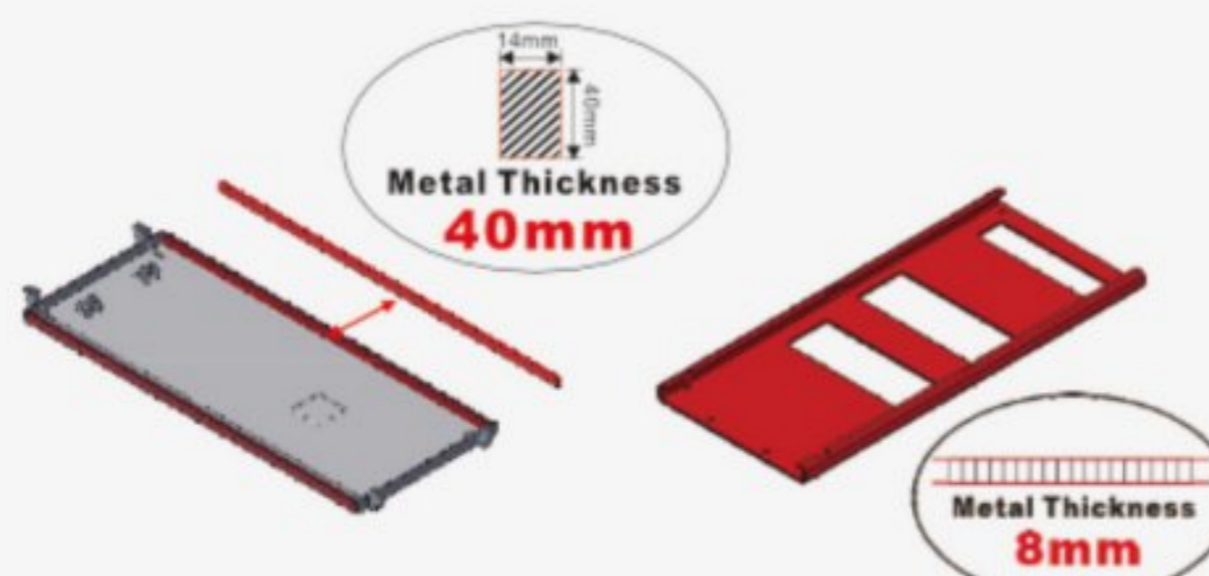
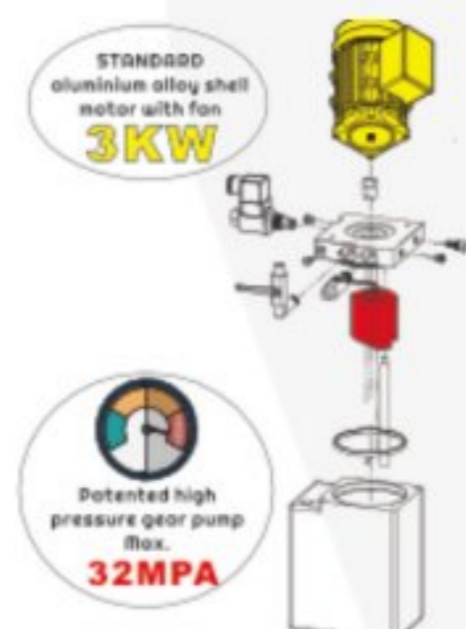

ES: Escanee el código para más información.

FR: Scannez le code pour plus d'informations.

EN: Scan the code for further information.

IT: Scansiona il codice per maggiori informazioni.

Königstein

3.5T

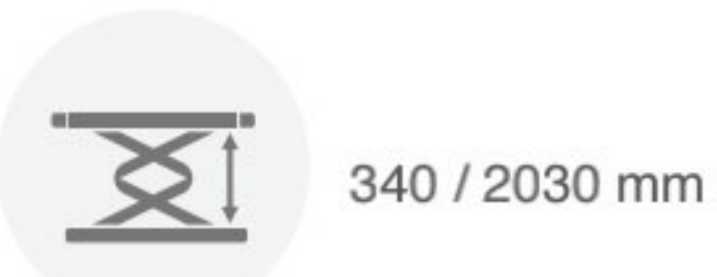

340 / 2030 mm



3500 kg



2030 mm



2220 mm



2,2 kw



(3 ~) 400/50V / Hz



880 kg

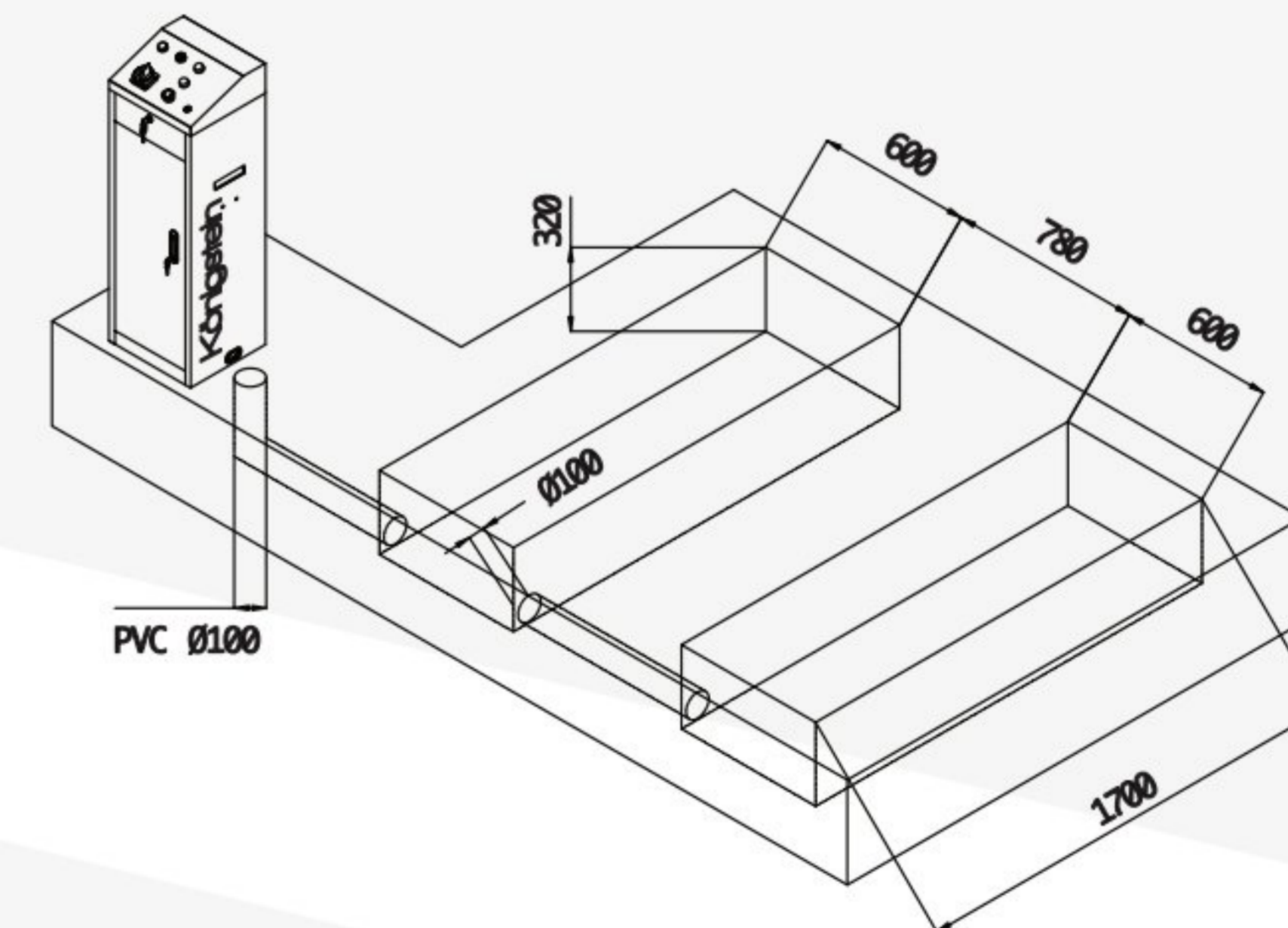
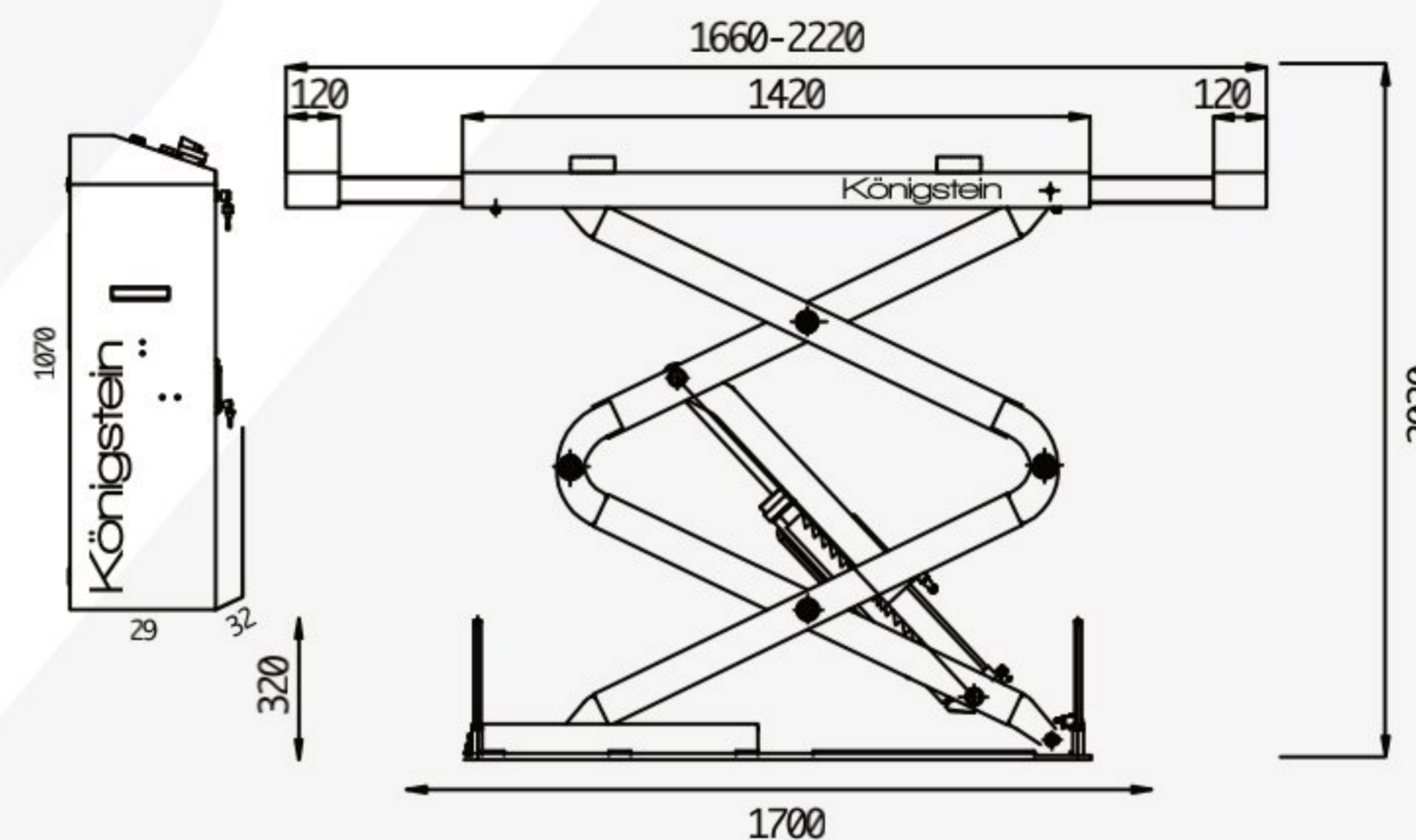
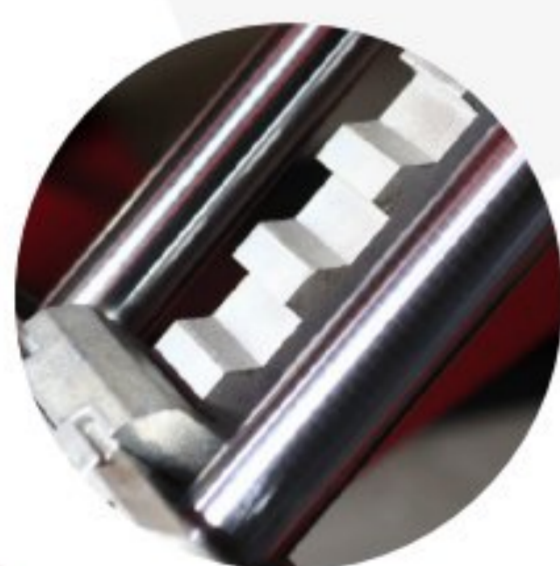

ELEVADOR DE TIJERAS PARA EMPOTRAR

- Fotocélula de nivelación que bloquea en caso de una descompensación accidental de la plataforma
- Sistema hidráulico con accionamiento principal/auxiliar y válvulas paracaídas de seguridad.

PONT ÉLÉVATEUR À DOUBLE CISEAUX À ENCASTER

- Photocellule de niveau qui se bloque en cas de décompression accidentelle de la plate-forme.
- Système hydraulique de qualité APLUS (pompe-piston) pour une longue durée de vie de l'équipement.

IN GROUND SCISSOR LIFT

- Leveling photocell that blocks in case of accidental decompression of the platform.
- Hydraulic system (pump-piston) of A-PLUS quality which guarantees a long life of the equipment.

SOLLEVATORE A FORBICE AD INCASSO

- Fotocellula di livellamento che blocca la macchina in caso di sbilanciamento accidentale della piattaforma.
- Sistema idraulico (pompa-pistone) di qualità A-PLUS che garantisce una lunga vita agli strumenti.

KN3635EX

Königstein



- Rampas extensibles hasta 2220 mm.
- Rampes extensibles à 2220 mm.
- Extendable ramps on both sides up to 2220 mm.
- Rampe estensibili fino 2220 mm.



ES: Escanee el código para más información.

FR: Scannez le code pour plus d'informations.

EN: Scan the code for further information.

IT: Scansiona il codice per maggiori informazioni.



Königstein

4T

KN3640E

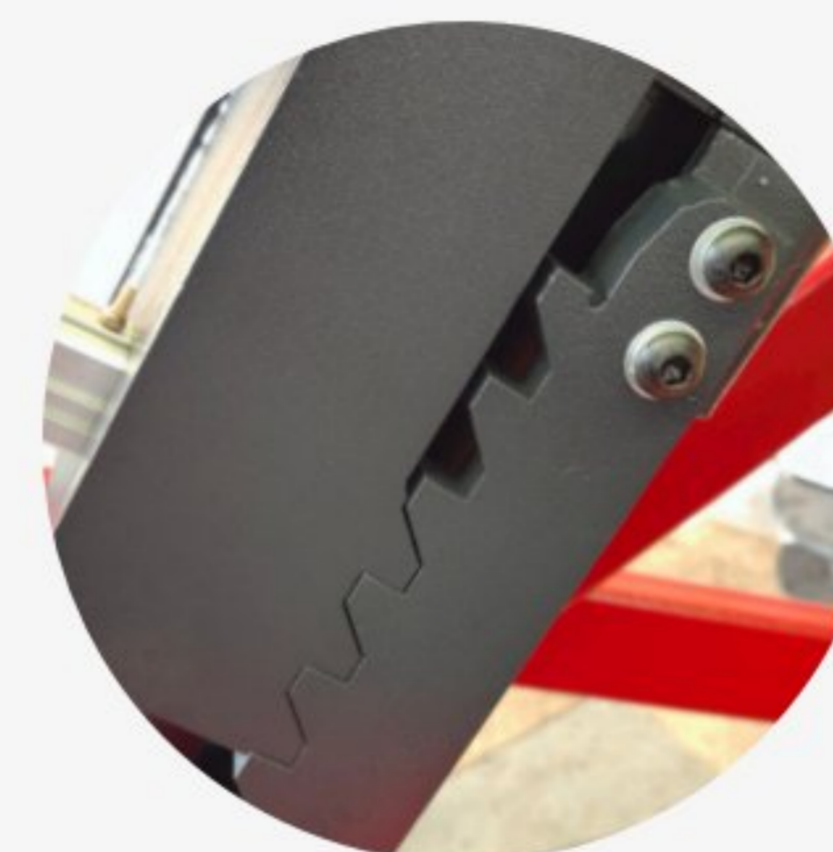

330 / 2010 mm



4000 kg

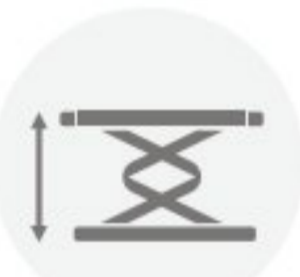

1680 mm



1660 mm



3,0 kw







(3 ~) 400/50V / Hz



880 kg

4T

-  Seguros mecánicos reforzados
-  Assurance mécanique renforcée
-  Reinforced mechanical lockers
-  Assicurazione meccanica rinforzata

 **ELEVADOR DE TIJERAS PARA EMPOTRAR DE 4000KG**

- Fococélula de nivelación que bloquea en caso de una descompensación accidental de la plataforma
- Sistema hidráulico con accionamiento principal/auxiliar y válvulas paracaídas de seguridad.

 **PONT ÉLÉVATEUR À DOUBLE CISEAUX À ENCASTER 4000KG**

- Photocellule de niveau qui se bloque en cas de décompression accidentelle de la plate-forme.
- Système hydraulique de qualité APLUS (pompe-piston) pour une longue durée de vie de l'équipement.

 **IN GROUND SCISSOR LIFT 4000KG**

- Leveling photocell that blocks in case of accidental decompression of the platform.
- Hydraulic system (pump-piston) of A-PLUS quality which guarantees a long life of the equipment.

 **SOLLEVATORE A FORBICE AD INCASSO 4000KG**

- Fococellula di livellamento che blocca la macchina in caso di sbilanciamento accidentale della piattaforma.
- Sistema idraulico (pompa-pistone) di qualità A-PLUS che garantisce una lunga vita agli strumenti.

KN3640E

Königstein

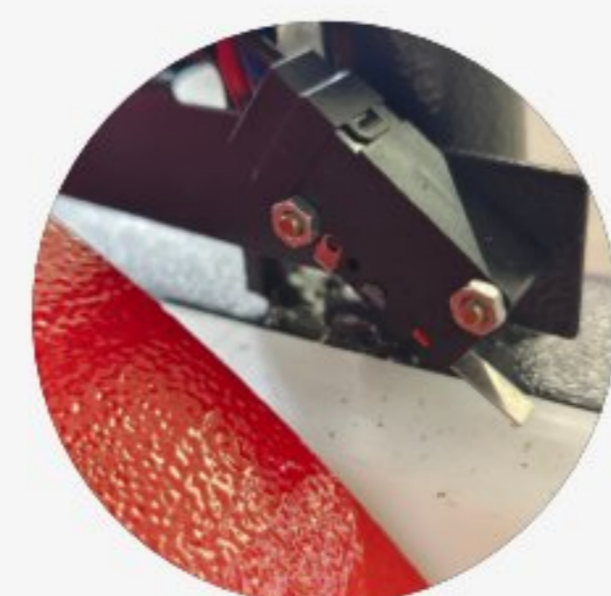
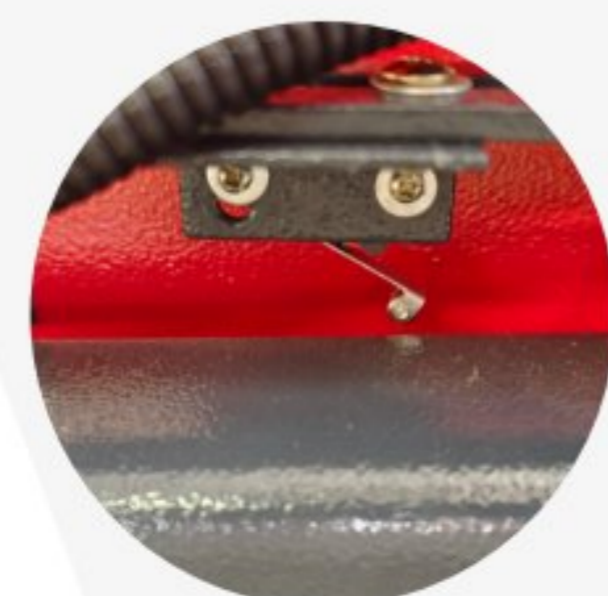

ES: Escanee el código para más información.

FR: Scannez le code pour plus d'informations.

EN: Scan the code for further information.

IT: Scansiona il codice per maggiori informazioni.



Königstein

NOTA: Las imágenes mostradas tienen el propósito de representar el producto solamente y pueden variar dependiendo del modelo y stock

3.5T

150/1000 mm

3500 kg

2030 mm

2220 mm

2,2 kw

(3 ~) 400/50V / Hz

.....

540 kg

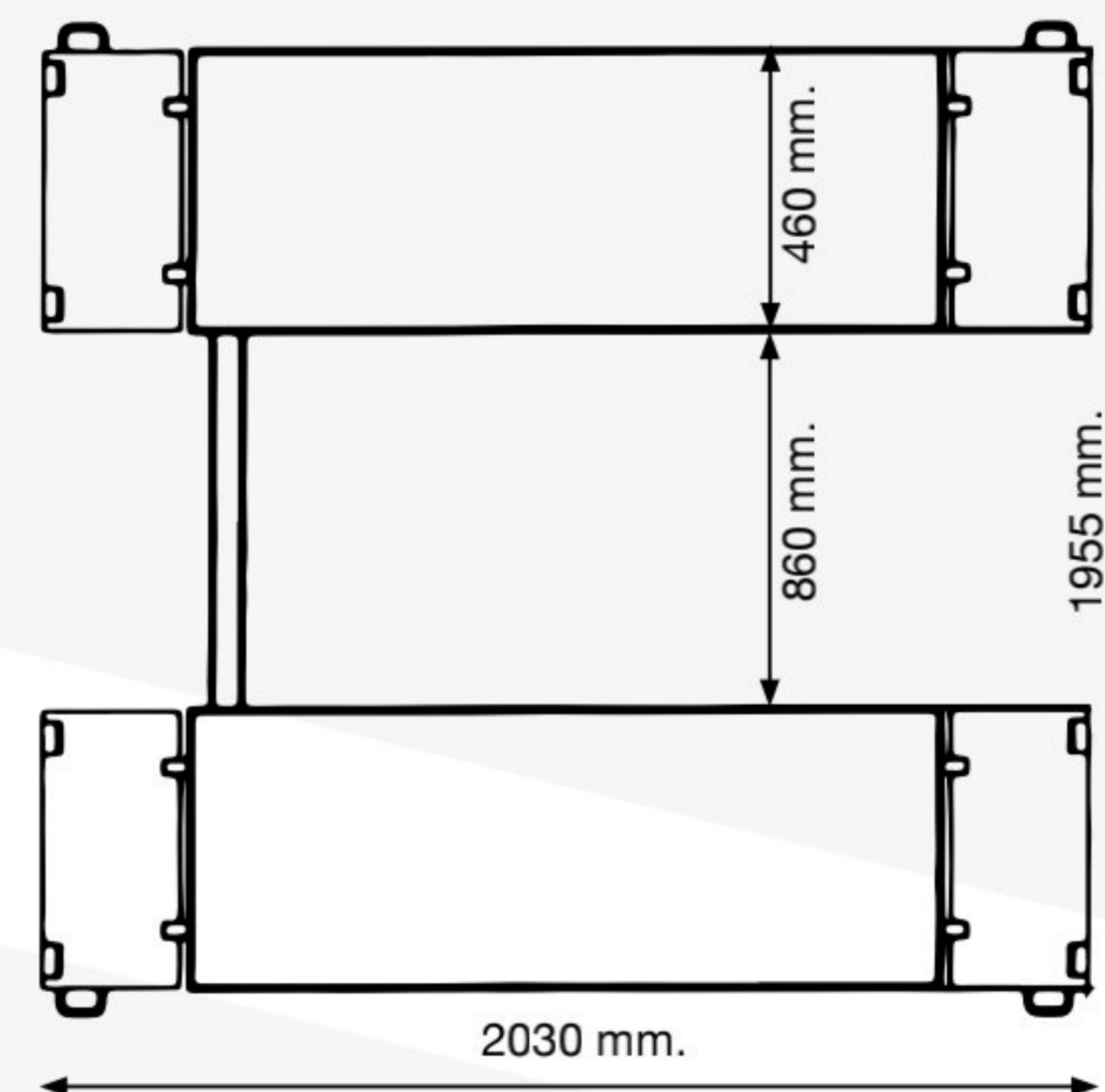
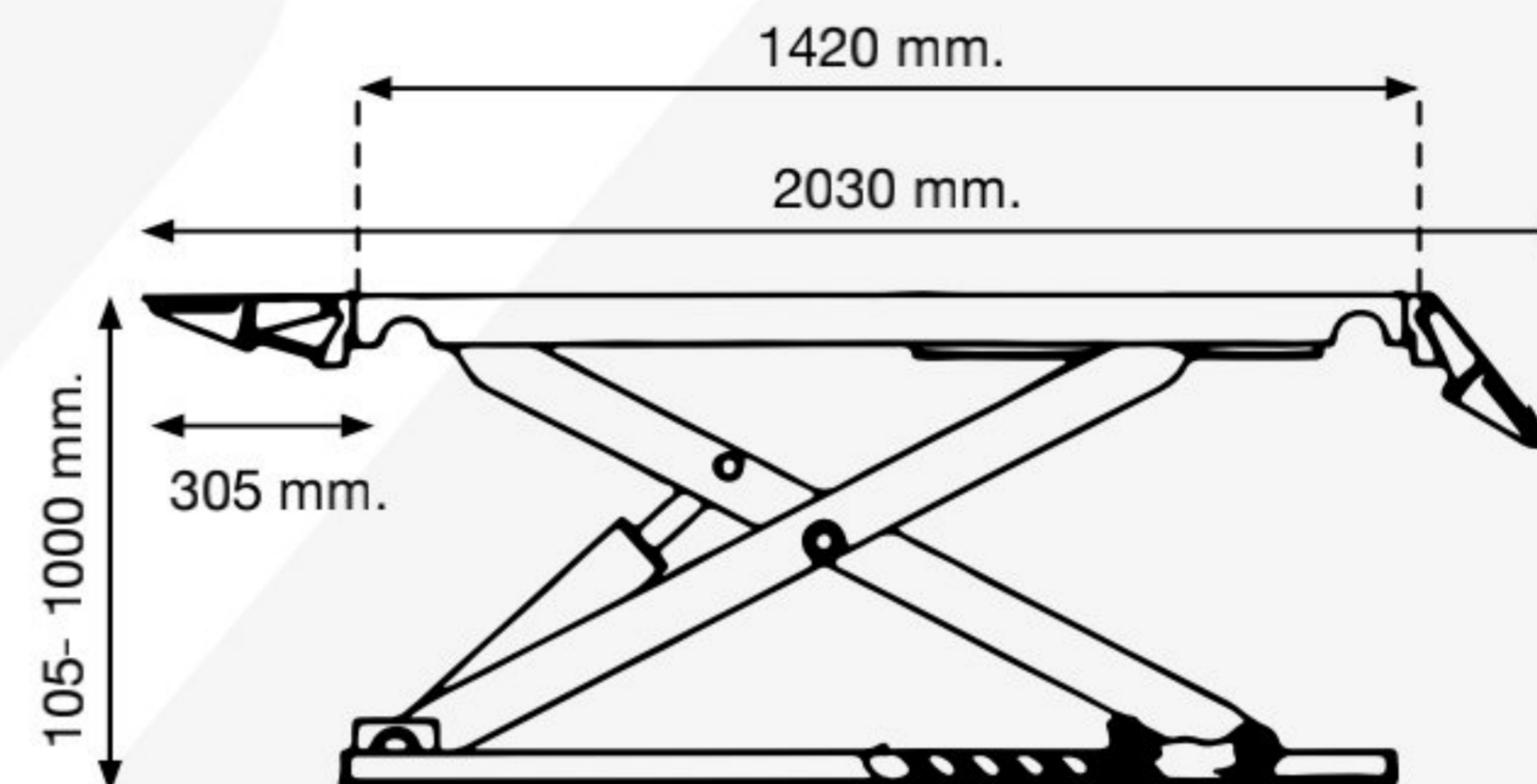

ELEVADOR DE TIJERAS NEUMATICO

- Construido con un eje de unión de las dos tijeras que garantizan la sincronización de las dos plataformas y el movimiento solidario de ambas.
- Pupitre con mandos a 24V y equipado con final de carrera en altura max. Del equipo.
- Desbloqueo neumático del sistema de seguros mecánicos.

PONT ÉLEVATEUR A CISEAUX

- Construit avec un axe qui relie les deux ciseaux ce qui garantit la synchronisation des deux platesformes et le mouvement solidarisé des deux.
- Pupitre avec commandes à 24V et équipé d'un interrupteur de fin de course à la hauteur maximale.
- Déblocage pneumatique du système de verrouillage mécanique.

LOW RISE SCISSOR LIFT IDEAL FOR TYRE SERVICE, PAINTING AND BODY WORK

- Built with a joint axis of the two scissors that guarantee the synchronization of the two platforms and the joint movement of both.
- "Dead man" controls 24V and equipped with runway-end at maximum height

SOLLEVATORE A FORBICE GOMMISTI

- Costruito con un asse che unisce le due forbici, garantendo la sincronizzazione e coordinazione delle due piattaforme.
- Postazione con comandi a 24V e dotata di finecorsa all'altezza massima dell'attrezzatura.
- Sblocco pneumatico del sistema di sicure meccaniche.

KN3635NX

Königstein



- Rampas extensibles hasta 2030 mm.
- Rampes extensibles à 2030 mm.
- Extendable ramps on both sides up to 2030 mm.
- Rampe estensibili fino 2030 mm.



ES: Escanee el código para más información.

FR: Scannez le code pour plus d'informations.

EN: Scan the code for further information.

IT: Scansiona il codice per maggiori informazioni.



3T

3.5T

 110-1000 mm

 3500 kg

 1000 mm

 2020 mm

 2,2 kw

 (1 ~) 230V/50Hz

 1450*1820*250mm
1200*500*400mm

 480 kg

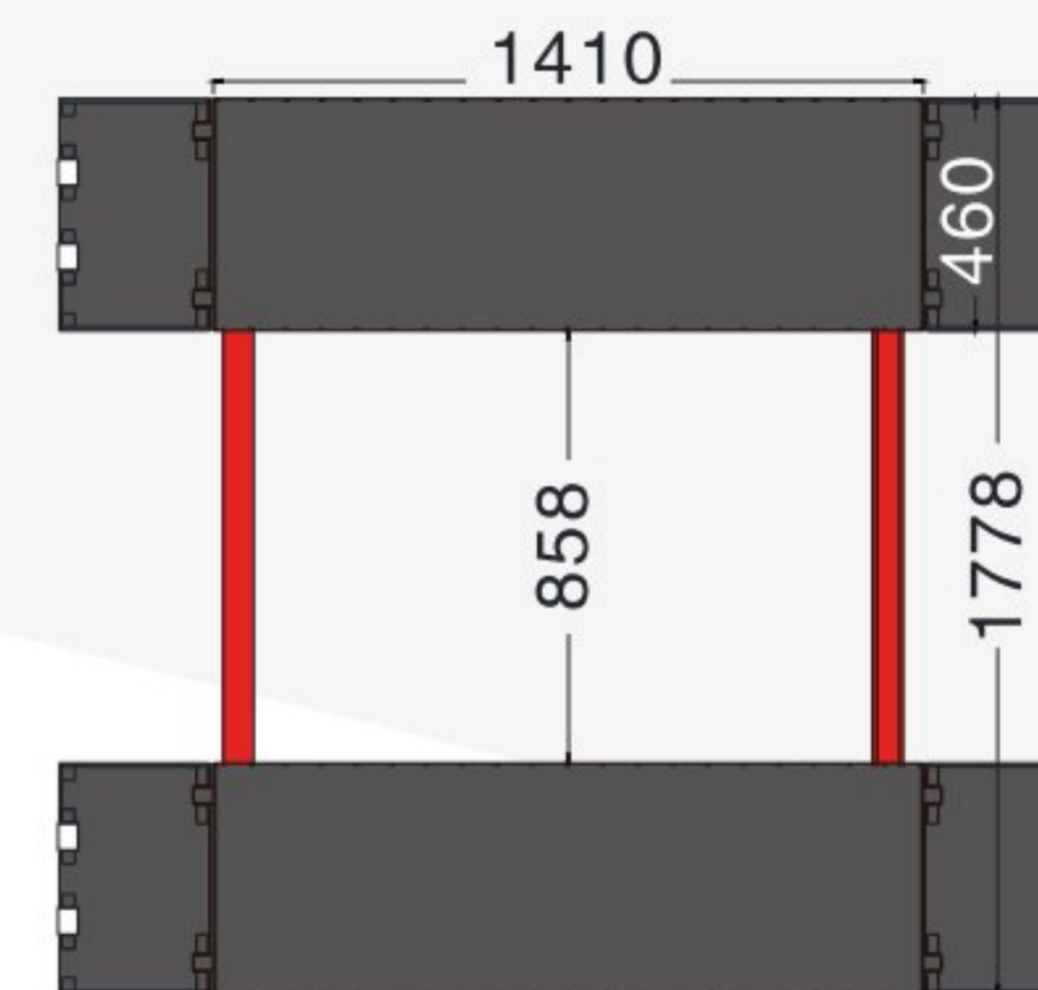
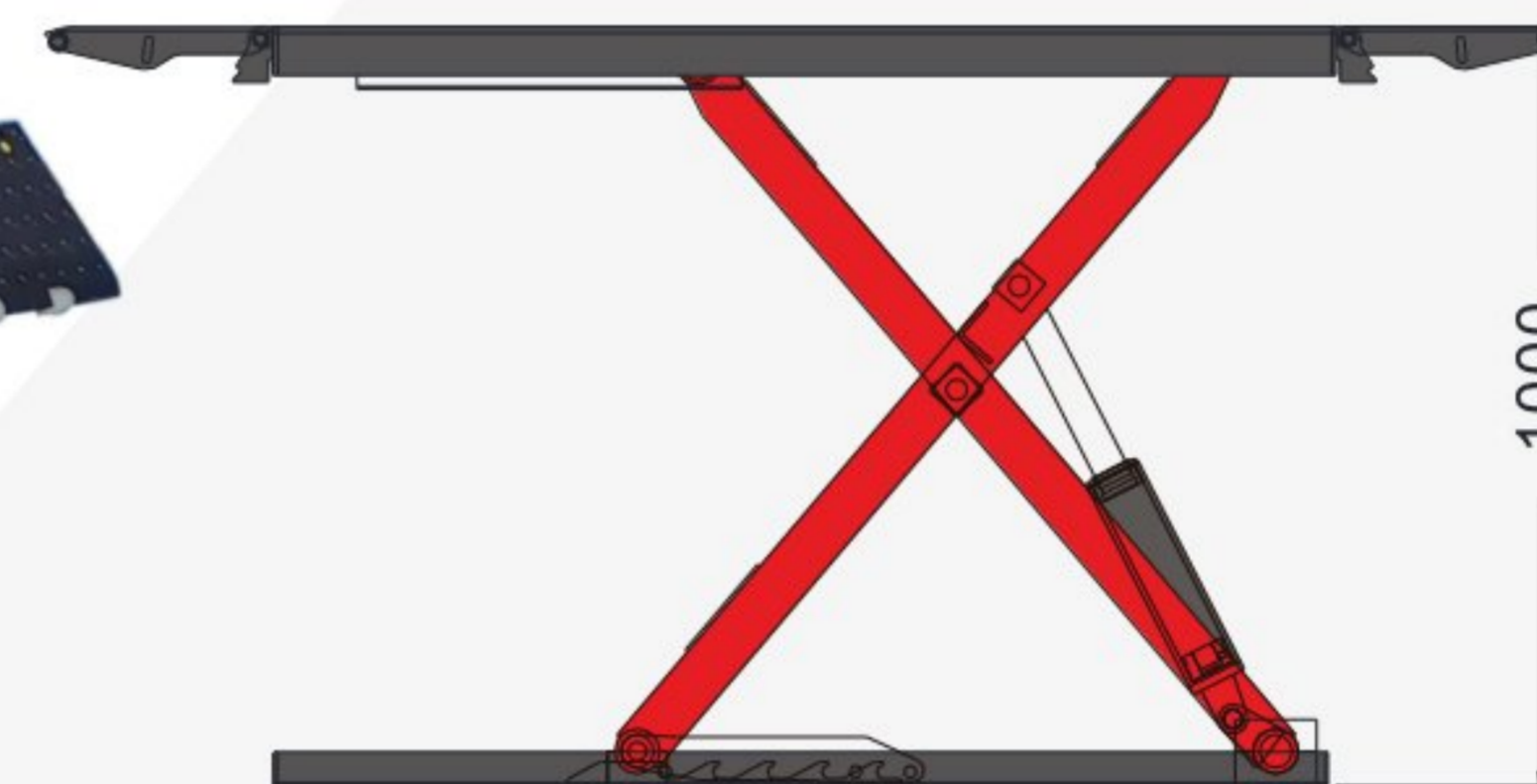

 **ELEVADOR DE TIJERAS NEUMATICO**

- Construido con un eje de unión de las dos tijeras que garantizan la sincronización de las dos plataformas y el movimiento solidario de ambas.
- Pupitre con mandos a 24V y equipado con final de carrera en altura max. Del equipo.
- Desbloqueo neumático del sistema de seguros mecánicos.

 **PONT ÉLÉVATEUR A CISEAUX**

- Construit avec un axe qui relie les deux ciseaux ce qui garantit la synchronisation des deux platesformes et le mouvement solidarisé des deux.
- Pupitre avec commandes à 24V et équipé d interrupteur de fin de course à la hauteur maximale.
- Déblocage pneumatique du système de verrouillage mécanique.

 **LOW RISE SCISSOR LIFT IDEAL FOR TYRE SERVICE, PAINTING AND BODY WORK**

- Built with a joint axis of the two scissors that guarantee the synchronization of the two platforms and the joint movement of both.
- "Dead man" controls 24V and equipped with runaway-end at maximum height

 **SOLLEVATORE A FORBICE GOMMISTI**

- Costruito con un asse che unisce le due forbici, garantendo la sincronizzazione e coordinazione delle due piattaforme.
- Postazione con comandi a 24V e dotata di finecorsa all'altezza massima dell'attrezzatura.
- Sblocco pneumatico del sistema di sicure meccaniche.

KN3635N

Königstein



ES: Escanee el código para más información.

FR: Scannez le code pour plus d'informations.

EN: Scan the code for further information.

IT: Scansiona il codice per maggiori informazioni.



Königstein

NOTA: Las imágenes mostradas tienen el propósito de representar el producto solamente y pueden variar dependiendo del modelo y stock

4.2T



450 mm
2060 mm



4200 kg



3000 kg



3 kw



(3 ~) 400/50V / Hz



2400 kg



KN3642DT



580 x 480 x 1300 mm
4630 x 650 x 460 mm (2)

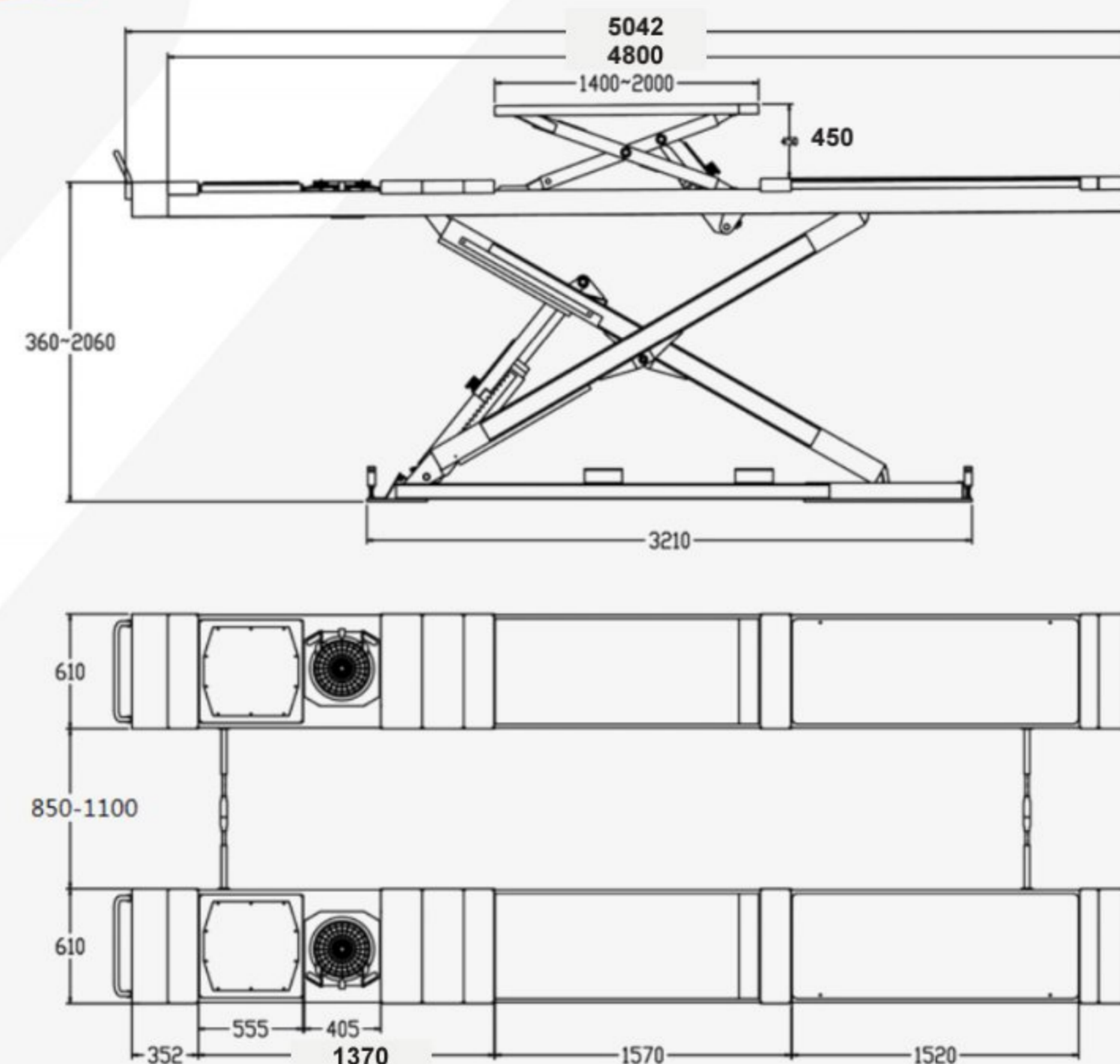

- 1:** Lámpara magnética, **2:** Sensor de bajada, **3:** Sensor infrarrojos, **4:** Bloqueo de rueda libre trasera.
- 1:** Lampe magnetique, **2:** Capteur de descente, **3:** Capteur infrarouge, **4:** Blocage de roues arrière.
- 1:** Magnetic lamp, **2:** Lowering sensor, **3:** Infrared sensor, **4:** Free wheel back lock.
- 1:** Lampada magnetica, **2:** Sensore di discesa, **3:** Sensore infrarossi, **4:** Blocco della ruota libera posteriore.

DOBLE TIJERA EMPOTRABLE

- Elevador de tijera para empotrar con elevador auxiliar integrado en las plataformas.
- Cavity para alojamiento de platos de alineación.
- Sistema mecánico de seguridad y desbloqueo neumático.

DOUBLE CISEAUX À ENCASTER

- Élévateur à ciseaux pour encastrer avec élévateur auxiliaire intégré dans les plates-formes.
- Cavité pour le logement des plaques d'alignement.
- Système mécanique de sécurité et déverrouillage pneumatique.

IN-GROUND BIG SCISSOR LIFT

- Scissor lift for built-in system. Provided with auxiliary lift integrated in the platforms.
- Casing for alignment plate.
- Mechanic security system and pneumatic unlock

PANTOGRAFO AD INCASSO

- Sollevatore a forbice ad incasso con sollevatore ausiliare integrato nelle piattaforme.
- Cavità per l'alloggiamento delle piastre di allineamento.
- Sistema meccanico di sicurezza e sblocco pneumatico.

KN3642DT

Königstein

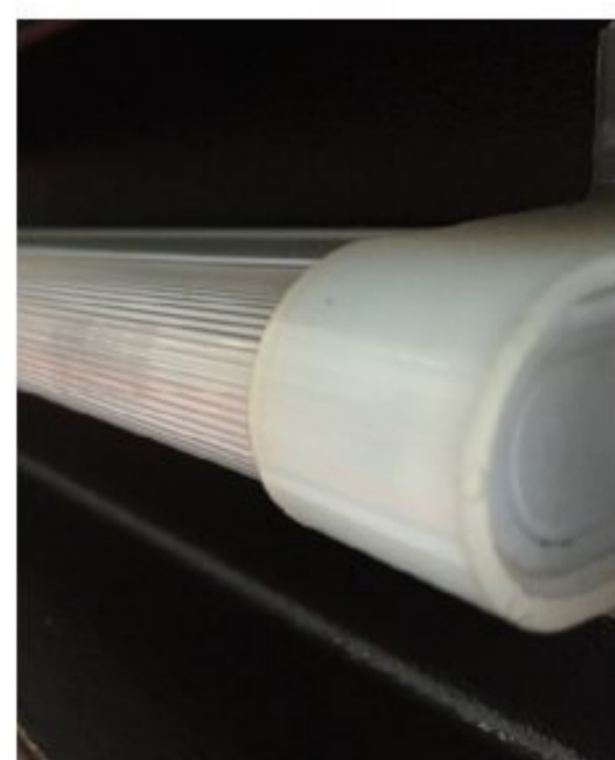

1



2



3

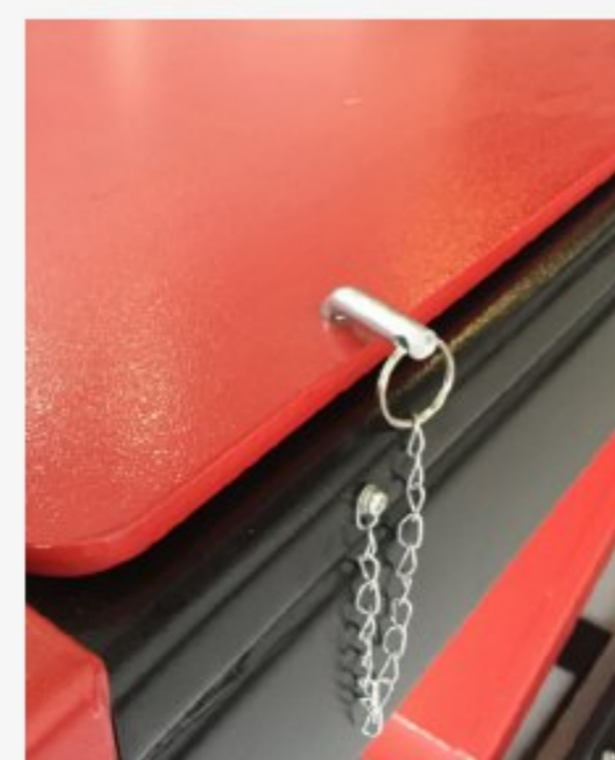

4



ES: Escanee el código para más información.

FR: Scannez le code pour plus d'informations.

EN: Scan the code for further information.

IT: Scansiona il codice per maggiori informazioni.



Königstein

4.5T



410 mm
1830 mm



4500 kg



3000 kg



3 kw



(3 ~) 400/50V / Hz



4850*660*320mm(2)
1160*500*500mm(1)
1600*620*300mm(1)

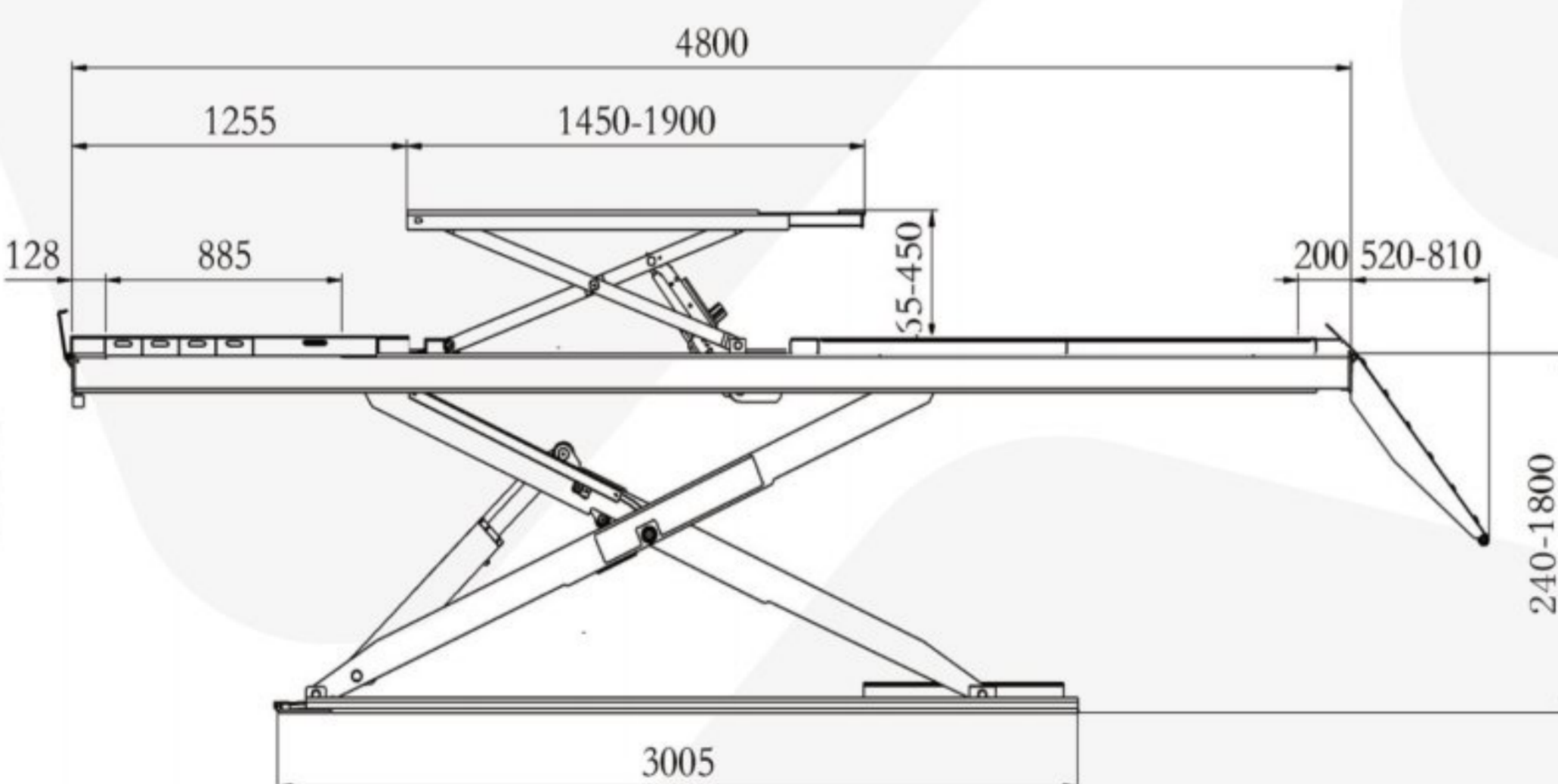

2184 kg



ELEVADOR DE DOBLE TIJERA SUPERFICIE PARA ALINEACIÓN

- Altura mínima de 240 mm ideal para instalaciones a ras de suelo.
- La altura máxima de elevación de las plataformas principales es de 1800 mm, el elevador auxiliar tiene rampas extensibles, ideal para vehículos largos.

PONT ÉLÉVATEUR À CISEAUX EN SURFACE AVEC ÉLÉVATEUR AUXILIAIRE INTÉGRÉ DANS LES PLATES-FORMES

- Hauteur minimale de 240 mm idéale pour installations au niveau du sol.
- La hauteur de levage maximale des plateformes principales est de 1800 mm, le pont élévateur auxiliaire a des rampes extensibles, idéales pour les véhicules longs.

DOUBLE SCISSORS LIFT 4.5T ON-GROUND

- Minimum height of 240 mm ideal for installations at ground level.
- The maximum lifting height of the main platforms is 1800mm, the auxiliary lift has extendable ramps, ideal for long vehicles.

SOLLEVATORE DOPPIA FORBICE SOPRA SUOLO

- Altezza minima di 240 mm ideale per le installazioni a livello del suolo.
- L'altezza massima del sollevamento delle piattaforme principali è di 1800 mm. Il sollevatore ausiliare ha rampe estensibili, ideali per veicoli lunghi.

KN3645DTS

Königstein



1



2

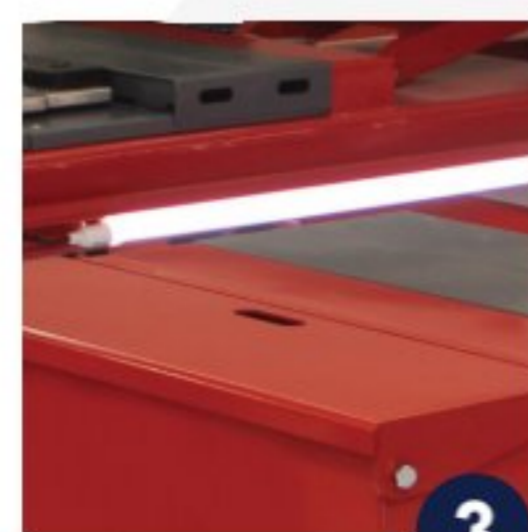

3

Rampa articulada,
Plataforma elevador
Auxiliar extensible,
Iluminación led incluida.

Rampe articulée,
Plateforme élévateur
Auxiliaire extensible,
Éclairage Led compris.

Articulated ramp, Extendable ramps, Led illumination

Rampa articolata, Piattaforma sollevatore ausiliare estensibile,
Illuminazione a led inclusa



ES: Escanee el código para más información.

FR: Scannez le code pour plus d'informations.

EN: Scan the code for further information.

IT: Scansiona il codice per maggiori informazioni.



NOTA: Las imágenes mostradas tienen el propósito de representar el producto solamente y pueden variar dependiendo del modelo y stock

4.5T

5.5T

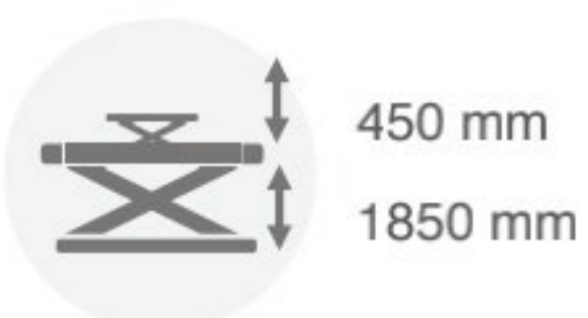

450 mm
1850 mm

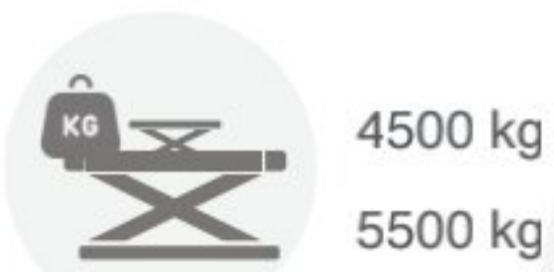

4500 kg
5500 kg



3000 kg



2,2 kw

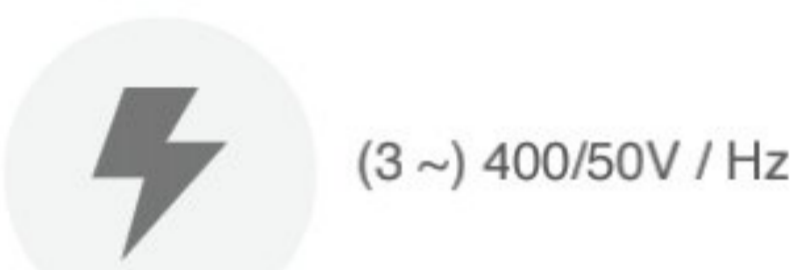

(3 ~) 400/50V / Hz



.....

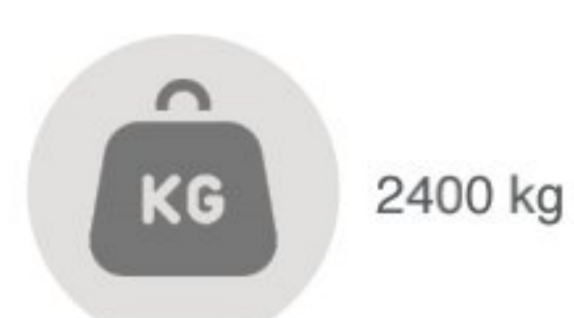

2400 kg



4.5T = 5000 mm | 5.5T = 5300 mm

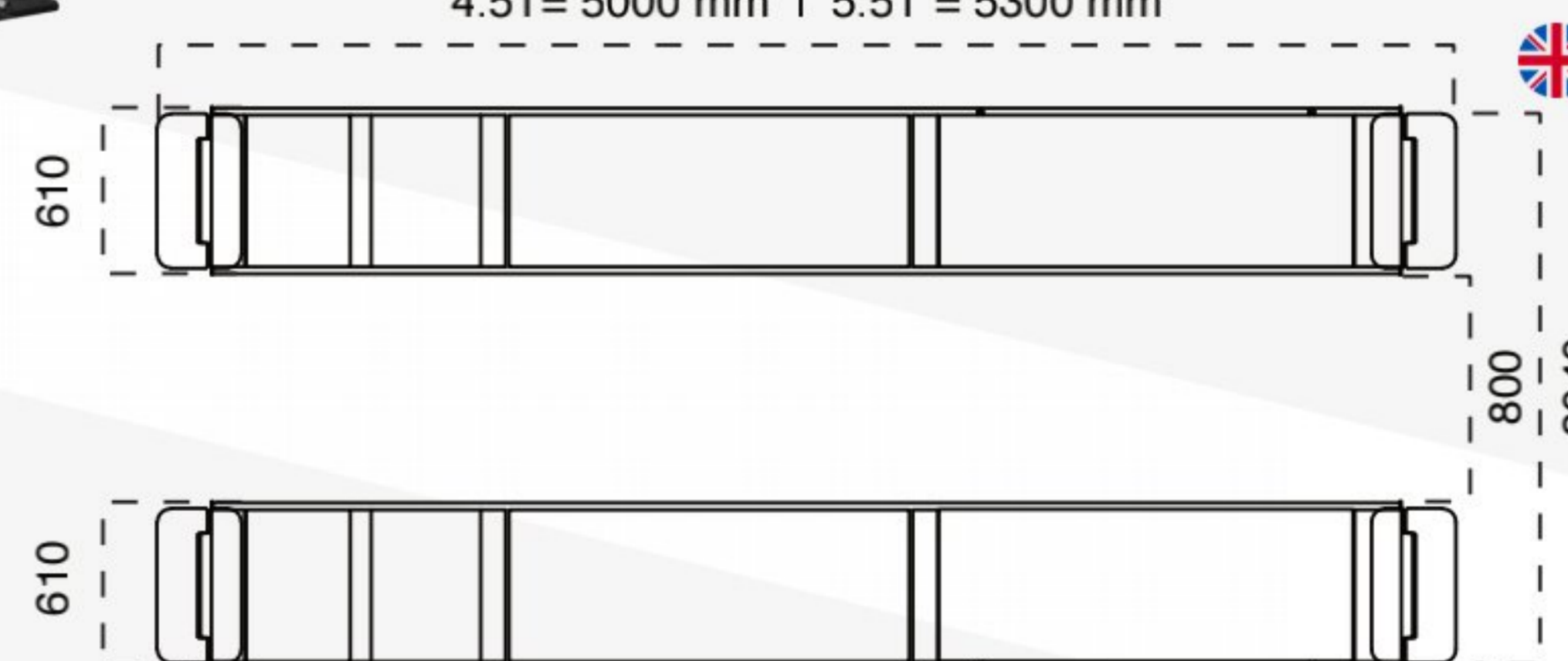
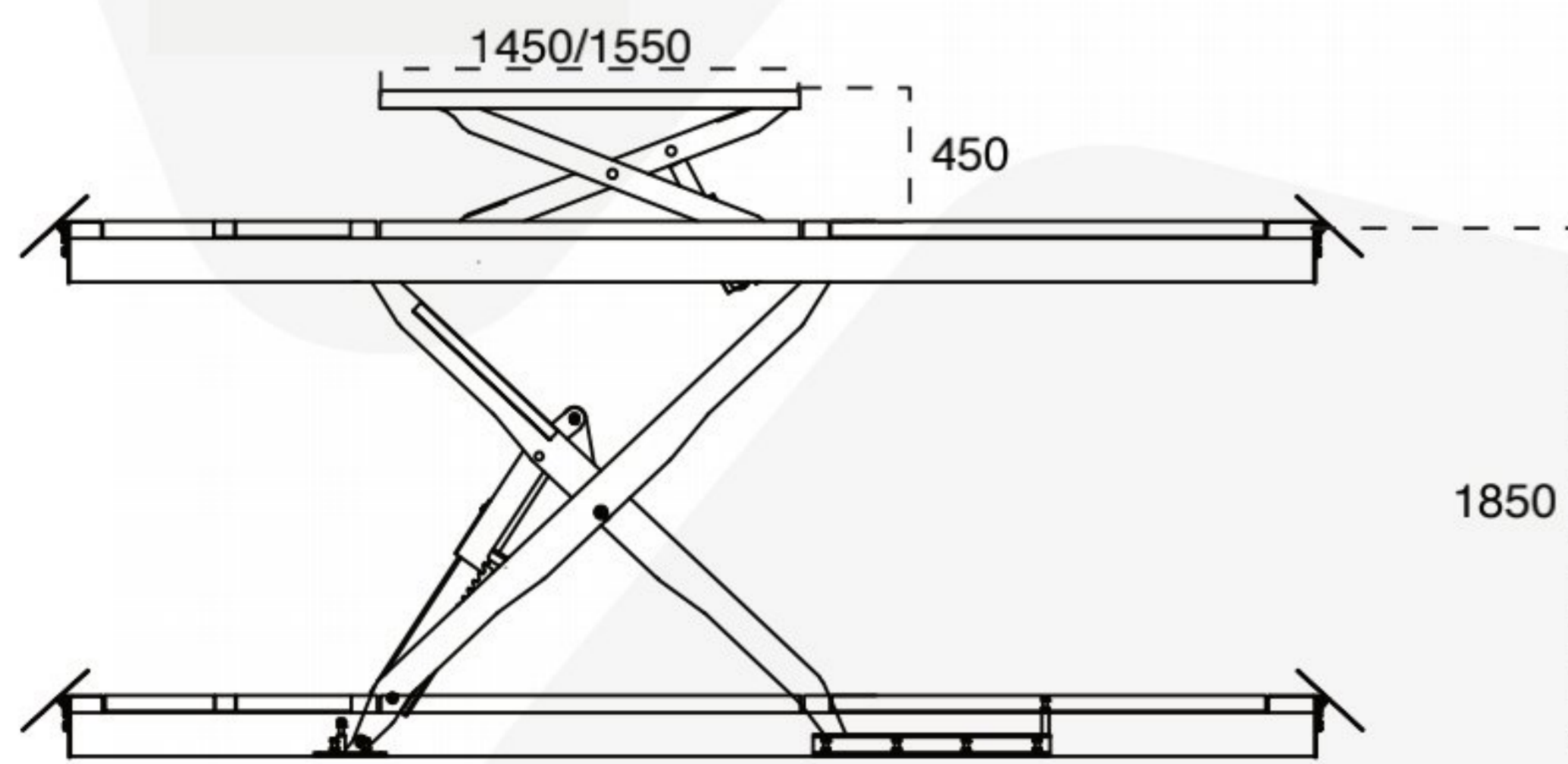

KN3645/55DTECO

Königstein



ELEVADOR DE DOBLE TIJERA EMPOTRABLE PARA ALINEACIÓN

- Altura mínima de 330 mm ideal para instalaciones a ras de suelo.
- La altura máxima de elevación de las plataformas principales es de 1850 mm, el elevador auxiliar tiene rampas extensibles, ideal para vehículos largos.

PONT ÉLÉVATEUR À CISEAUX AVEC ÉLÉVATEUR AUXILIAIRE INTÉGRÉ DANS LES PLATES-FORMES

- Hauteur minimale de 330 mm idéale pour installations au niveau du sol.
- La hauteur de levage maximale des plateformes principales est de 1850 mm, le pont élévateur auxiliaire a des rampes extensibles, idéales pour les véhicules longs.

DOUBLE SCISSORS LIFT 4.5T IN-GROUND

- Minimum height of 330 mm ideal for installations at ground level.
- The maximum lifting height of the main platforms is 1850 mm, the auxiliary lift has extendable ramps, ideal for long vehicles.

SOLLEVATORE DOPPIA FORBICE

- Altezza minima di 330 mm ideale per le installazioni a livello del suolo.
- L'altezza massima del sollevamento delle piattaforme principali è di 1850 mm. Il sollevatore ausiliare ha rampe estensibili, ideali per veicoli lunghi.



ES: Escanee el código para más información.

EN: Scan the code for further information.

FR: Scannez le code pour plus d'informations.

IT: Scansiona il codice per maggiori informazioni.



NOTA: Las imágenes mostradas tienen el propósito de representar el producto solamente y pueden variar dependiendo del modelo y stock

5.5T



500 mm
1980 mm



5500 kg



5500 kg



3 kw



(3 ~) 400/50V / Hz



5260 x 693 x 422 (2)
440 x 360 x 960 (1)
400 x 400 x 250 (1)



2970 kg

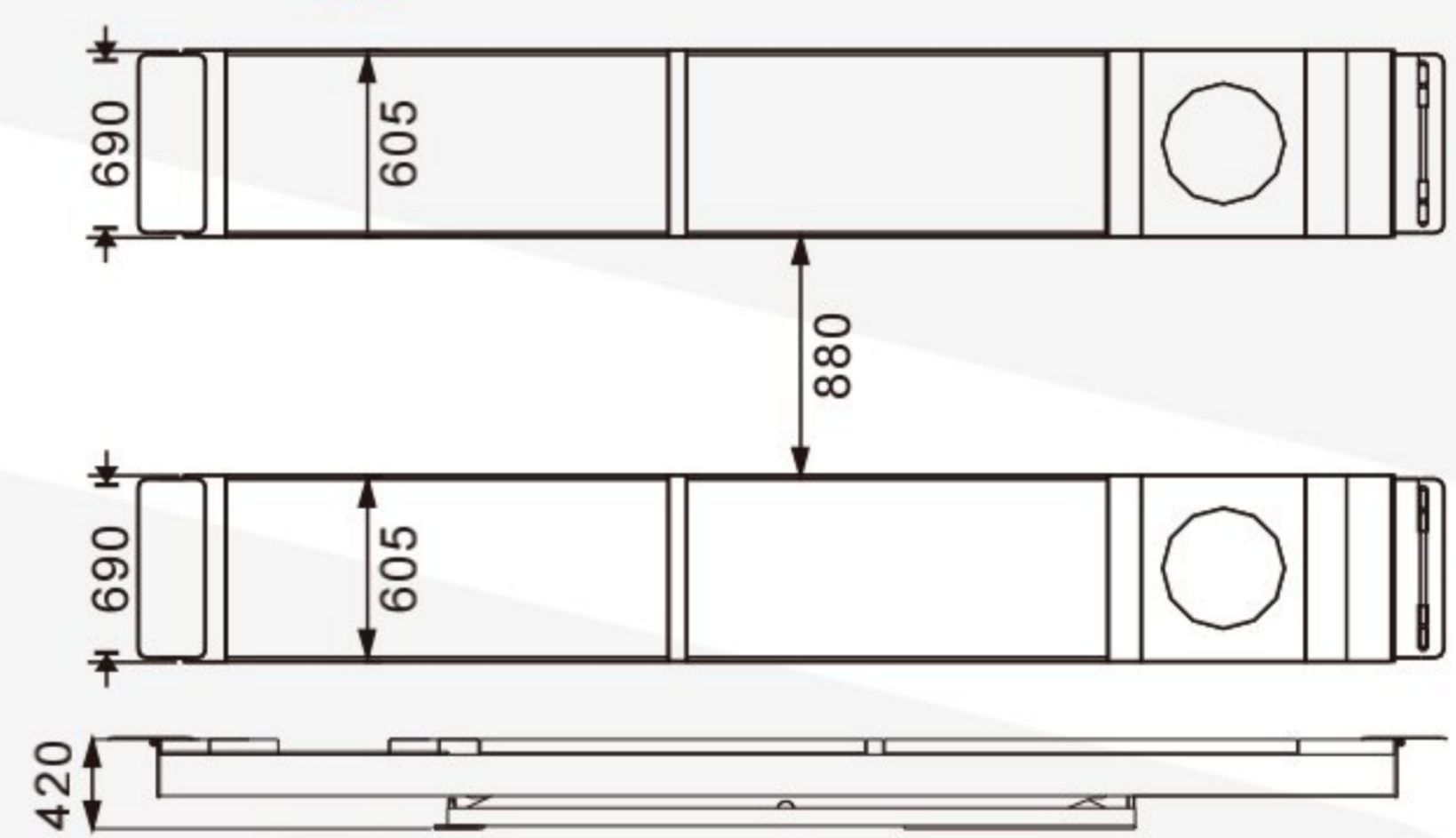
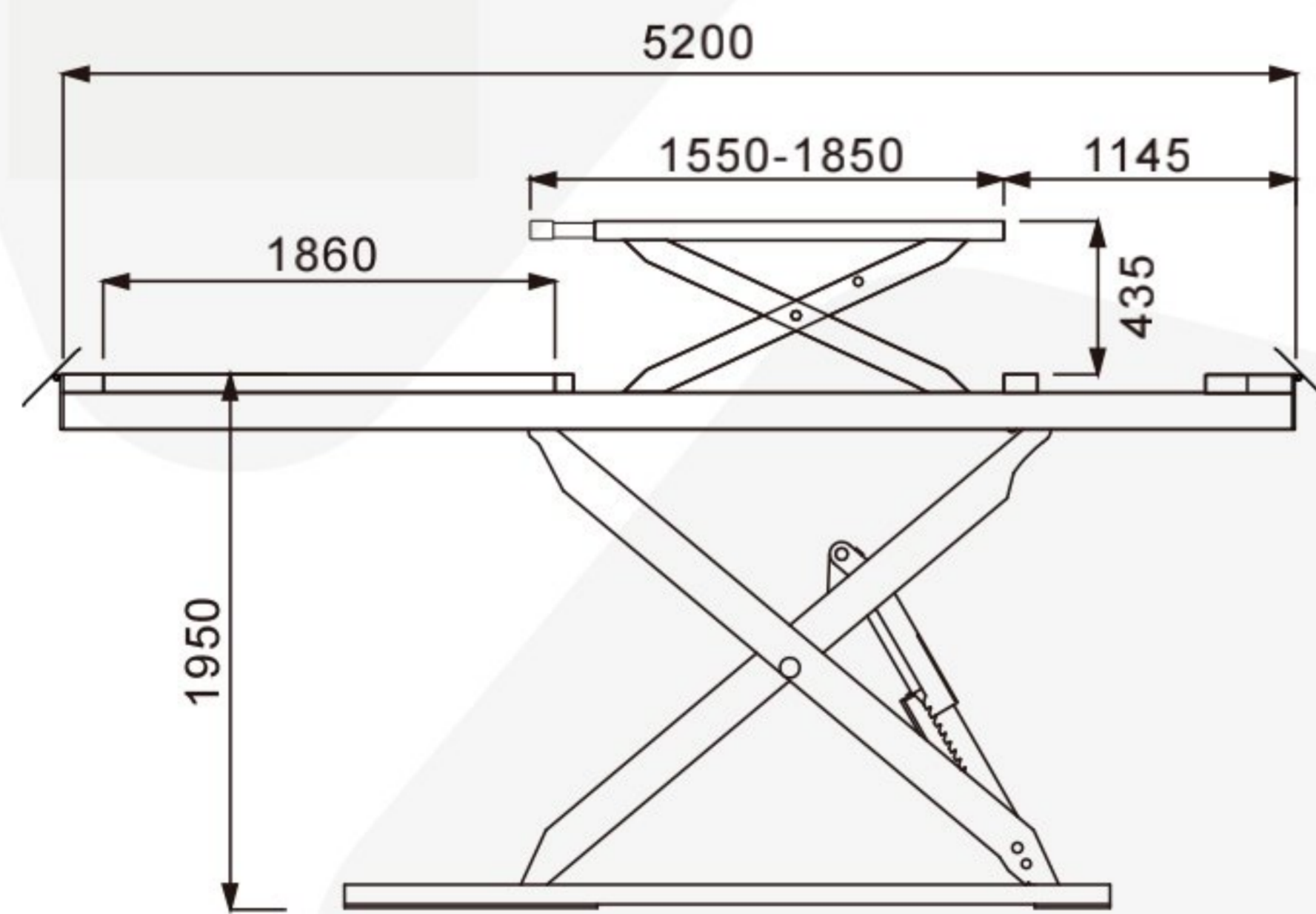

ELEVADOR DE DOBLE TIJERA EMPOTRABLE PARA ALINEACIÓN

- Altura mínima de 420 mm ideal para instalaciones a ras de suelo.
- La altura máxima de elevación de las plataformas principales es de 1950 mm, el elevador auxiliar tiene rampas extensibles, ideal para vehículos largos.

PONT ÉLÉVATEUR À CISEAUX AVEC ÉLÉVATEUR AUXILIAIRE INTÉGRÉ DANS LES PLATES-FORMES

- Hauteur minimale de 420 mm idéale pour installations au niveau du sol.
- La hauteur de levage maximale des plateformes principales est de 1850 mm, le pont élévateur auxiliaire a des rampes extensibles, idéales pour les véhicules longs.

DOUBLE SCISSORS LIFT 4.5T IN-GROUND

- Minimum height of 420 mm ideal for installations at ground level.
- The maximum lifting height of the main platforms is 1950 mm, the auxiliary lift has extendable ramps, ideal for long vehicles.

SOLLEVATORE DOPPIA FORBICE

- Altezza minima di 420 mm ideale per le installazioni a livello del suolo.
- L'altezza massima del sollevamento delle piattaforme principali è di 1950 mm. Il sollevatore ausiliare ha rampe estensibili, ideali per veicoli lunghi.

KN3645/55DTECO

Königstein



ES: Escanee el código para más información.
EN: Scan the code for further information.
FR: Scannez le code pour plus d'informations.
IT: Scansiona il codice per maggiori informazioni.



NOTA: Las imágenes mostradas tienen el propósito de representar el producto solamente y pueden variar dependiendo del modelo y stock

4T

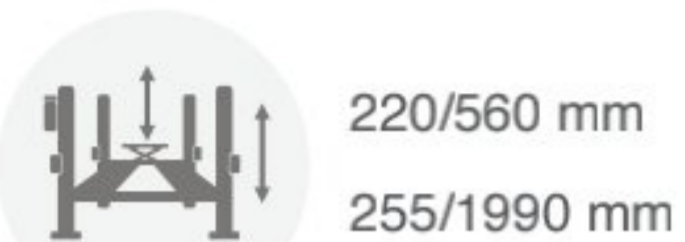

220/560 mm
255/1990 mm



3000 kg



4000 kg



2,2 kw

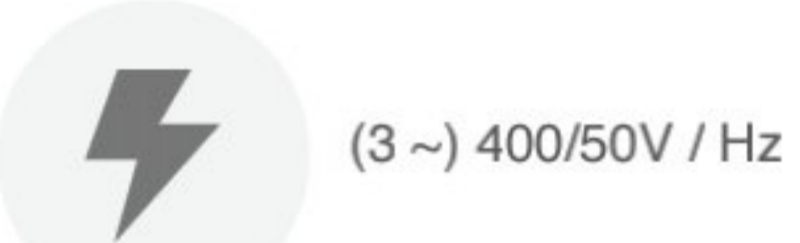

(3 ~) 400/50V / Hz

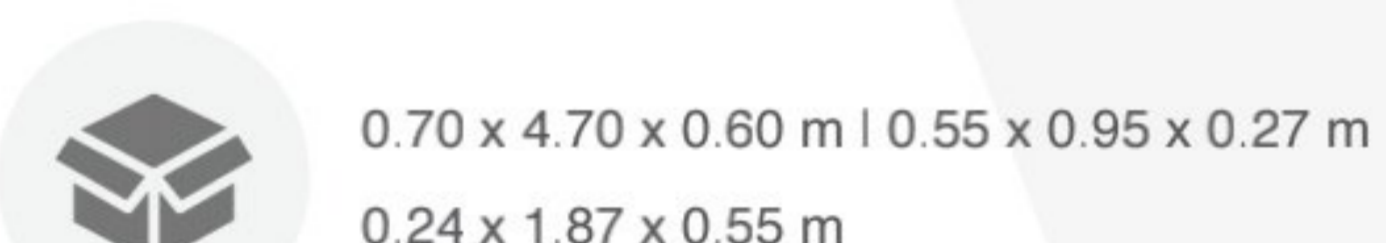



0.70 x 4.70 x 0.60 m | 0.55 x 0.95 x 0.27 m
0.24 x 1.87 x 0.55 m



1200 kg



-  Gato central Opcional
-  Cric central Optionnel
-  Optional central jack
-  Presa centrale opzionale

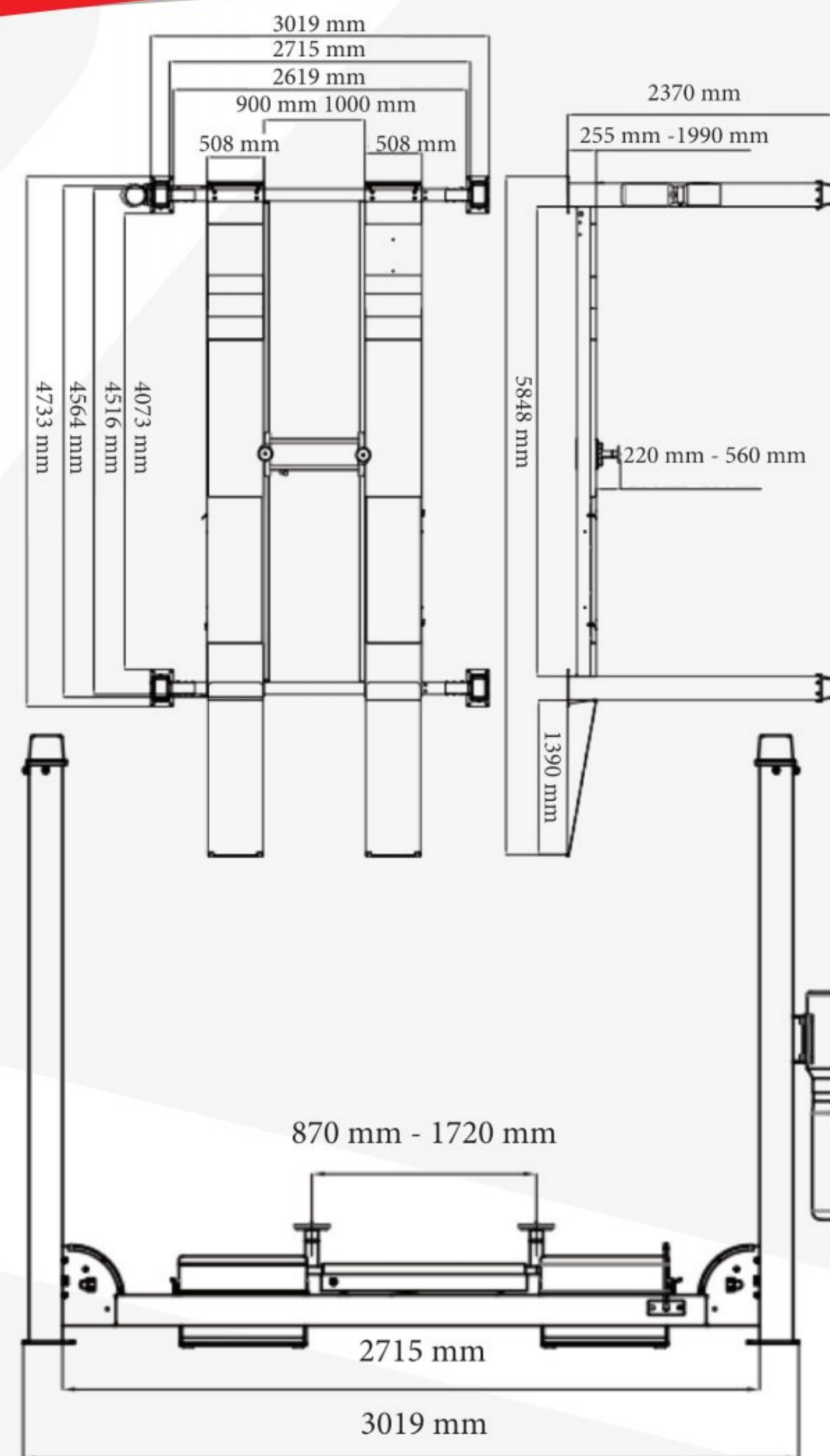

PASARELAS EQUIPADAS PARA ALINEACIÓN (HUECO PARA PLATOS Y RUEDAS LIBRES TRASERAS)

- Largas y anchas plataformas para vehículos con amplias distancias entre ruedas y para uso cómodo del operario
- Sistema hidráulico sin desgaste, y larga duración y con poca necesidad de mantenimiento

PASSERELLES ÉQUIPÉES POUR L'ALIGNEMENT (TROU POUR LES PLATEAUX) ET ROUES LIBRES ARRIÈRE

- Plateformes longues et larges pour les véhicules à large empattement et pour une utilisation confortable par l'opérateur.
- Système hydraulique sans usure, durable et nécessitant peu d'entretien.

RUNWAYS EQUIPPED FOR ALIGNMENT (SPACE FOR PLATE AND FREE REAR WHEEL)

- Long and wide platforms to work comfortable.
- Wear-free hydraulic system for long life.

PASSERELLE ATTREZZATE PER L'ALLINEAMENTO (INCAVO PER RUOTE LIBERE POSTERIORI)

- Piattaforme lunghe e larghe per veicoli con un'ampia distanza tra ruote e per un uso comodo dell'operatore.
- Sistema idraulico senza usura, a lunga durata e a bassa manutenzione.

Königstein

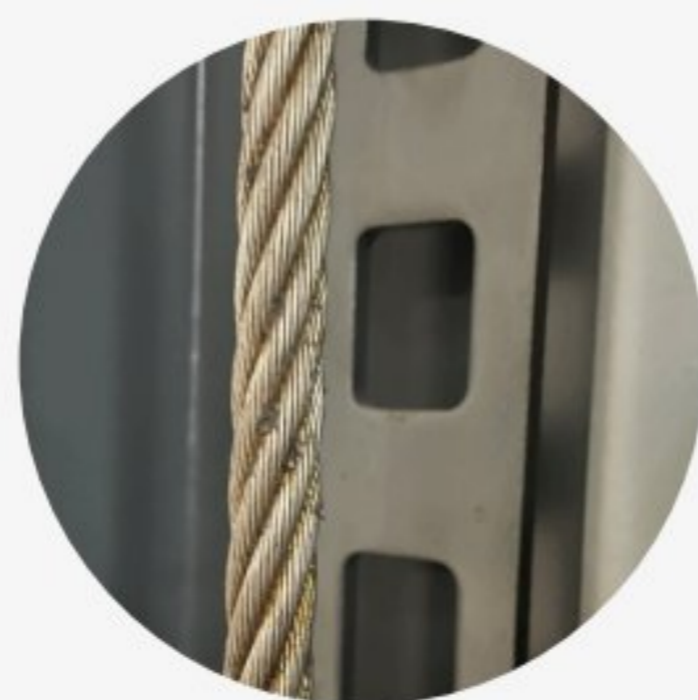
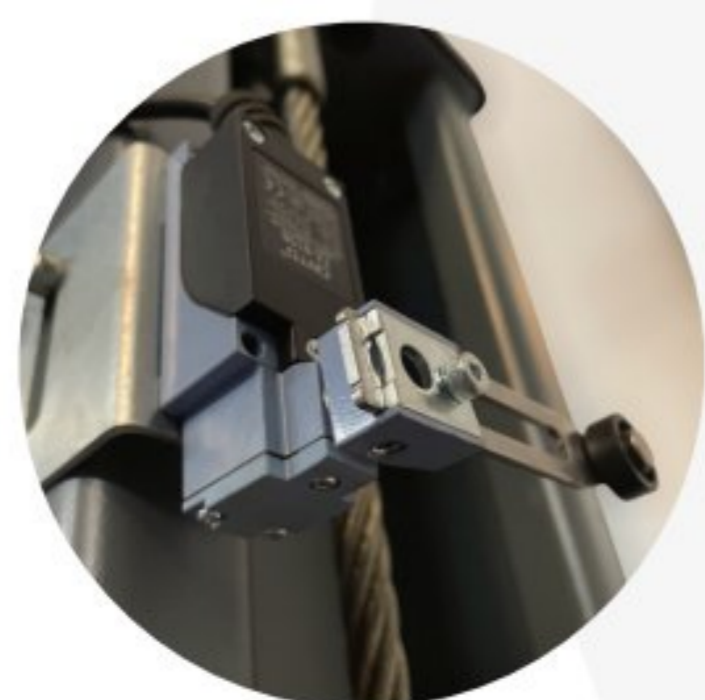

ES: Escanee el código para más información.

FR: Scannez le code pour plus d'informations.

EN: Scan the code for further information.

IT: Scansiona il codice per maggiori informazioni.



5T



220/560 mm
255/1990 mm



3000 kg



5000 kg



2,2 kw

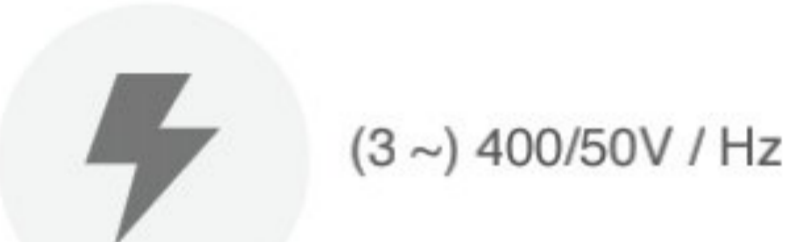

(3 ~) 400/50V / Hz





0.60 x 5.4 x 0.75 m - 0.30 x 1.3 x 0.58 m - 0.44 x 1.62 x 0.55 m - 0.32 x 1.21 x 0.36 m - 0.35 x 1 x 0.36 m



1200 kg



-  Gato central Opcional
-  Cric central Optionnel
-  Optional central jack
-  Presa centrale opzionale

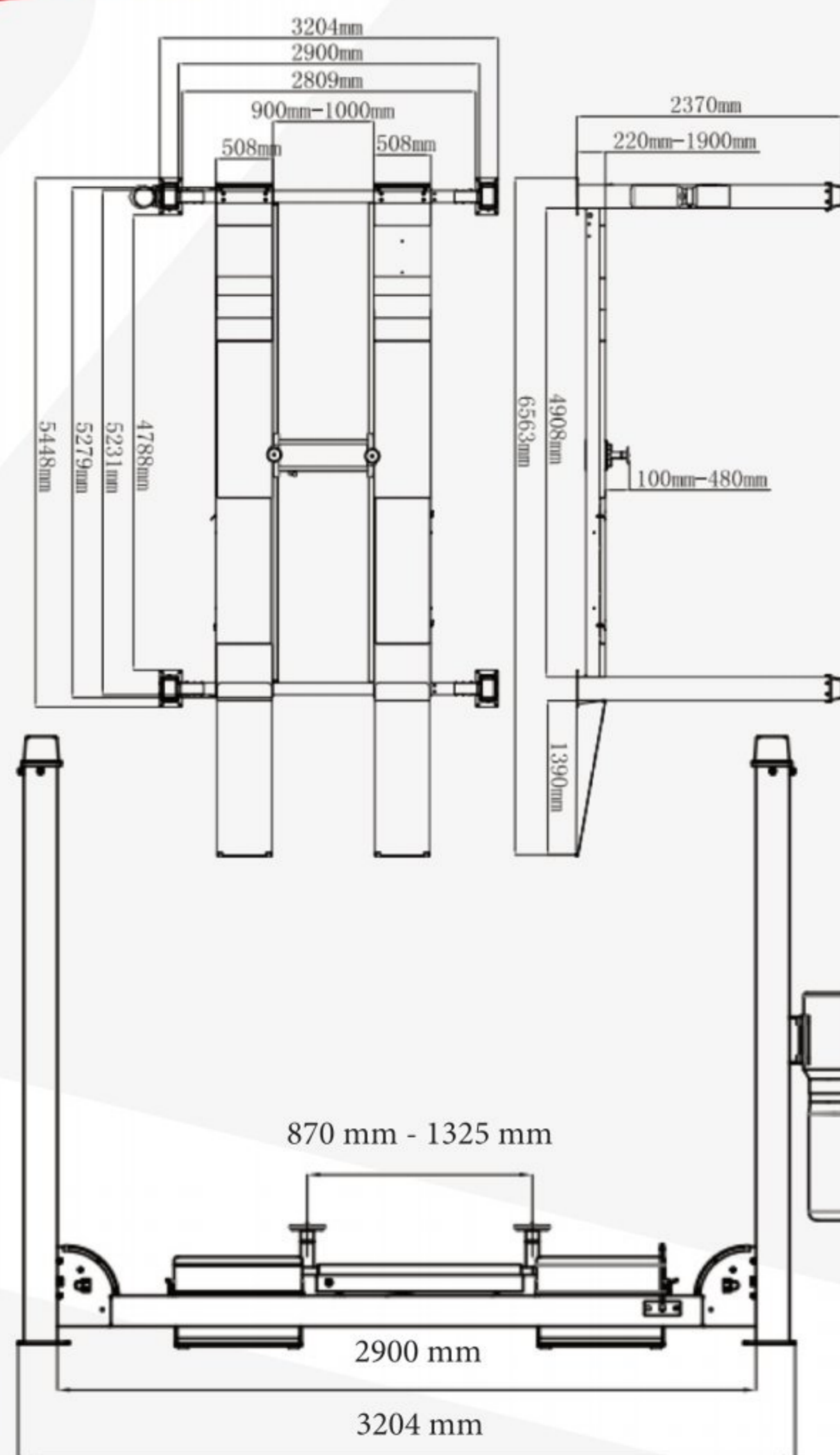

 **PASARELAS EQUIPADAS PARA ALINEACIÓN (HUECO PARA PLATOS Y RUEDAS LIBRES TRASERAS)**

- Largas y anchas plataformas para vehículos con amplias distancias entre ruedas y para uso cómodo del operario
- Sistema hidráulico sin desgaste, y larga duración y con poca necesidad de mantenimiento

 **PASSERELLES ÉQUIPÉES POUR L'ALIGNEMENT (TROU POUR LES PLATEAUX) ET ROUES LIBRES ARRIÈRE**

- Plateformes longues et larges pour les véhicules à large empattement et pour une utilisation confortable par l'opérateur.
- Système hydraulique sans usure, durable et nécessitant peu d'entretien.

 **RUNWAYS EQUIPPED FOR ALIGNMENT (SPACE FOR PLATE AND FREE REAR WHEEL)**

- Long and wide platforms to work comfortable.
- Wear-free hydraulic system for long life.

 **PASSERELLE ATTREZZATE PER L'ALLINEAMENTO (INCABO PER RUOTE LIBERE POSTERIORI)**

- Piattaforme lunghe e larghe per veicoli con un'ampia distanza tra ruote e per un uso comodo dell'operatore.
- Sistema idraulico senza usura, a lunga durata e a bassa manutenzione.

KN3450A

Königstein

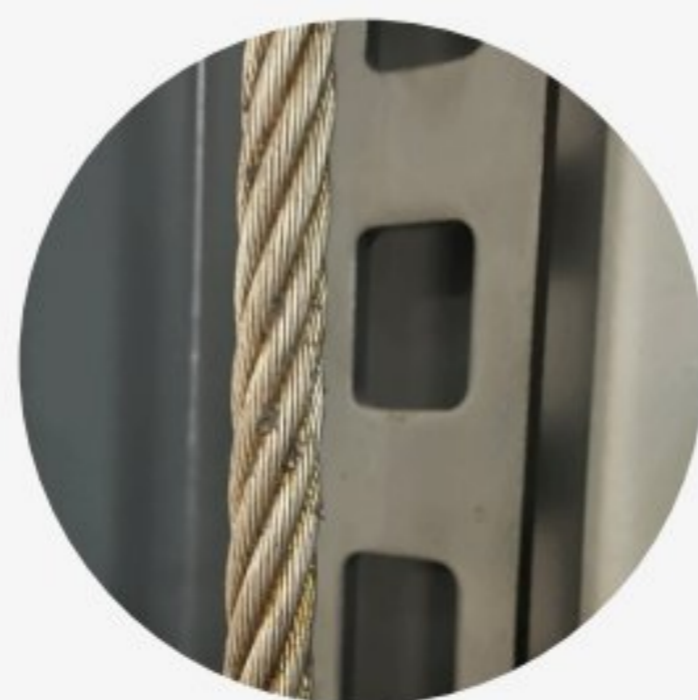
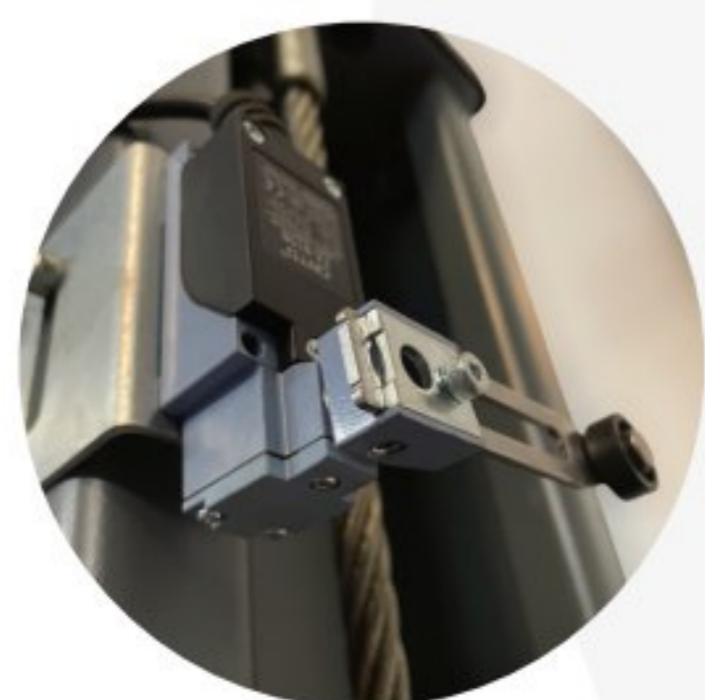

ES: Escanee el código para más información.

FR: Scannez le code pour plus d'informations.

EN: Scan the code for further information.

IT: Scansiona il codice per maggiori informazioni.



Königstein

5T

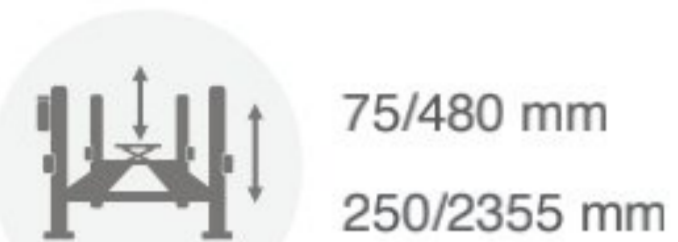

75/480 mm
250/2355 mm



3000 kg



5000 kg

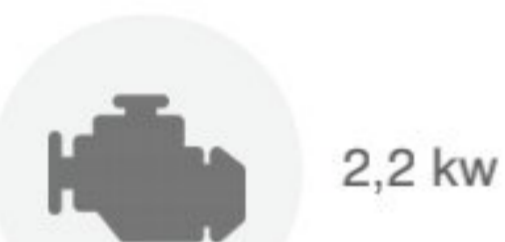

2,2 kw



(3 ~) 400/50V / Hz

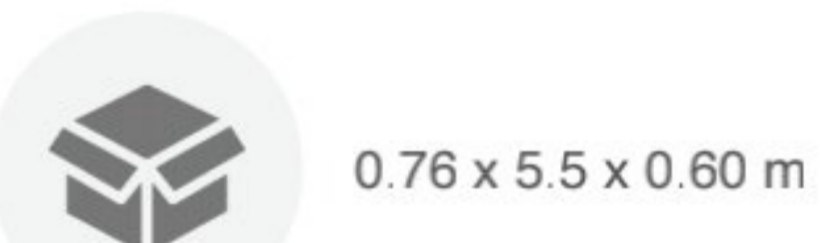

0.76 x 5.5 x 0.60 m



1500 kg

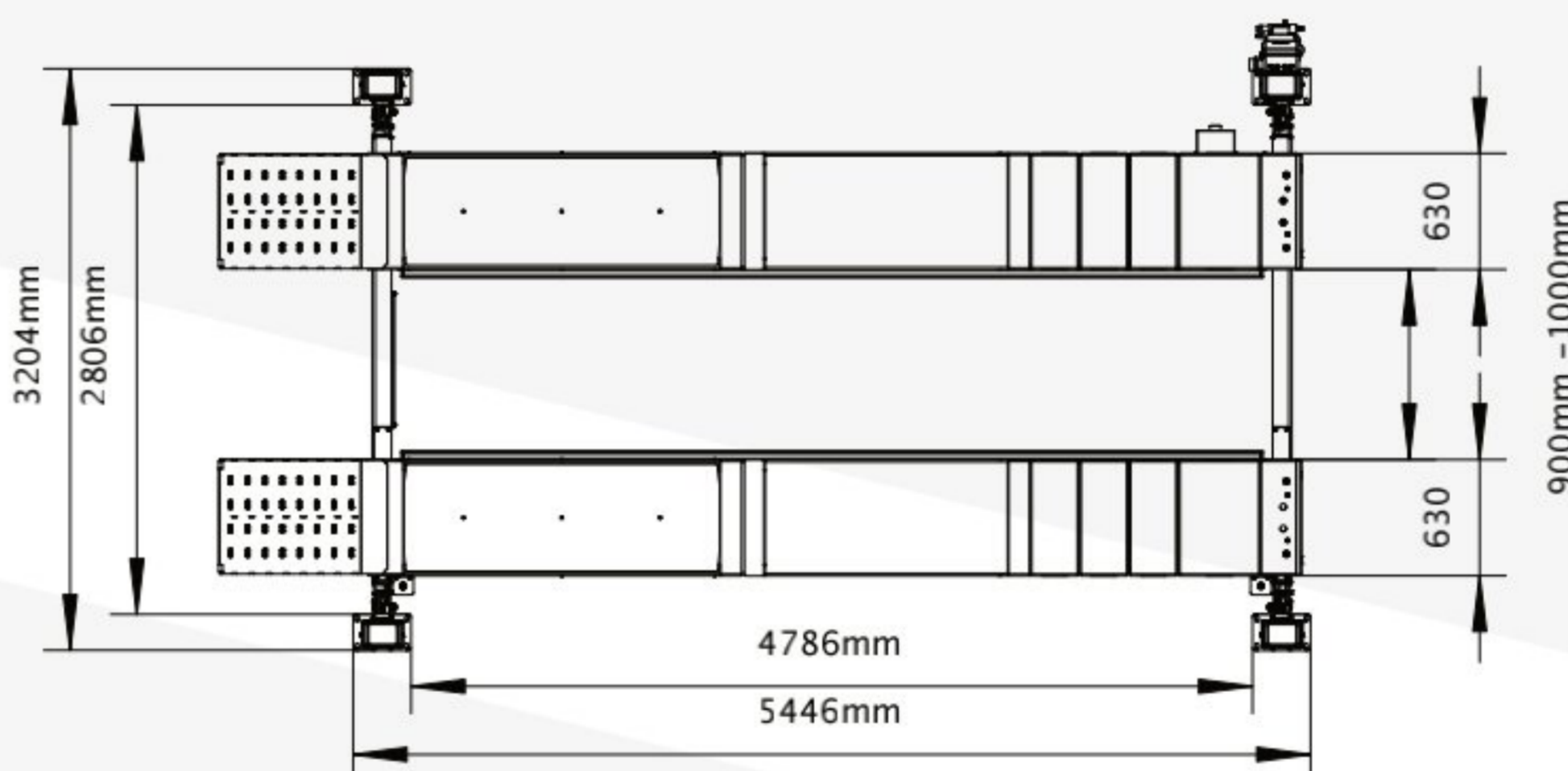
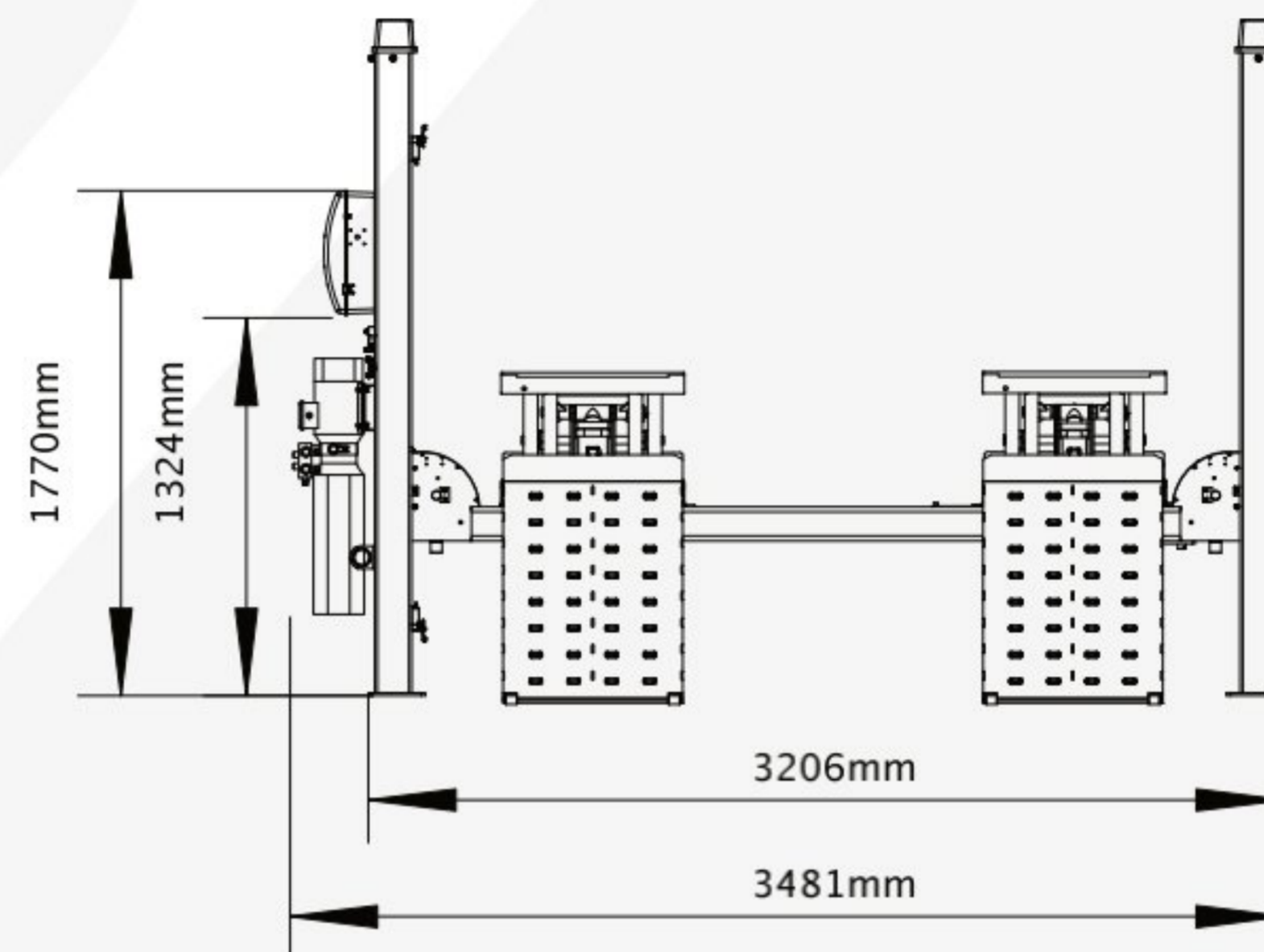
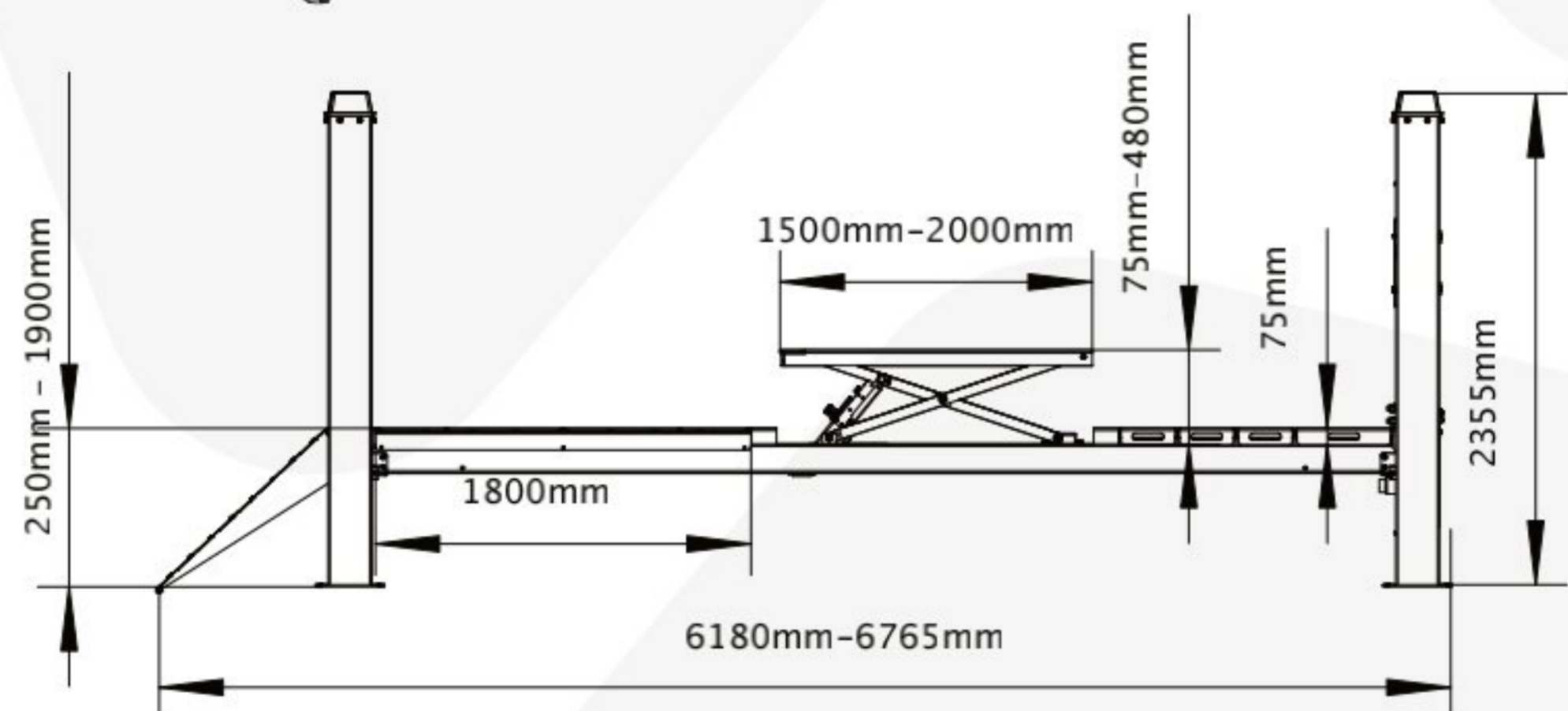

4 COLUMNAS CON ELEVADOR AUXILIAR DE DOBLE TIJERA

- Final de carrera superior
- Rampas de ancho ajustable para diferentes tipos de vehículos.
- Sub-elevador de tijeras auxiliar con plataforma extensible con capacidad de carga de 3.5T

4 COLONNES AVEC DOUBLE ÉLÉVATEUR À CISEAUX

- Fin de course supérieure
- Rampes réglables en largeur pour différents types de véhicules.
- Elévateur auxiliaire à ciseaux avec plateforme extensible d'une capacité de charge de 3,5T

4 POSTS WITH AUXILIARY DOUBLE SCISSOR LIFT

- Superior travel end.
- Adjustable wide ramps.
- Auxiliary scissors sub-lift with extendable platform with lift capacity of 3.5T

4 COLONNE CON SOLLEVATORE AUSILIARE DOPPIA FORBICE

- Finecorsa superiore
- Rampe di larghezza regolabile per diverse tipologie di veicoli.
- Sub-sollevatore a forbice ausiliare con piattaforma estensibile con capacità di carico di 3.5T

NOTA: Las imágenes mostradas tienen el propósito de representar el producto solamente y pueden variar dependiendo del modelo y stock

KN3450DT

Königstein

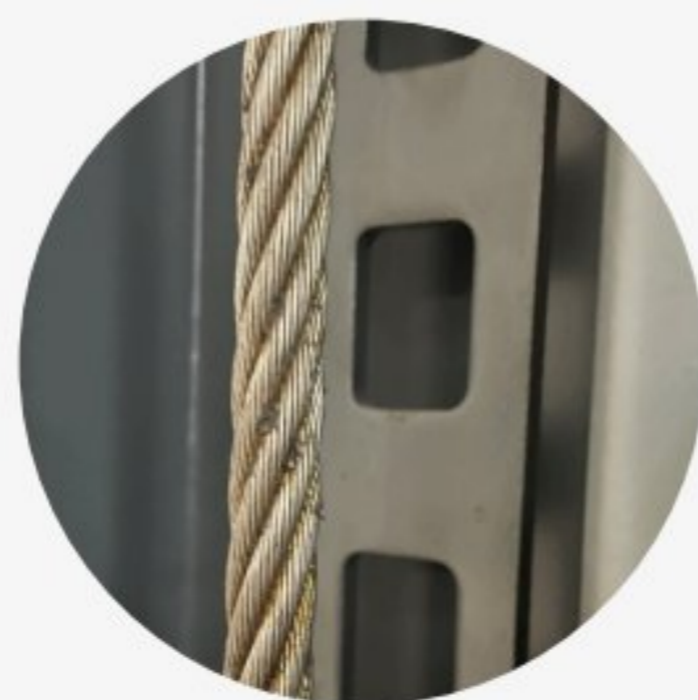
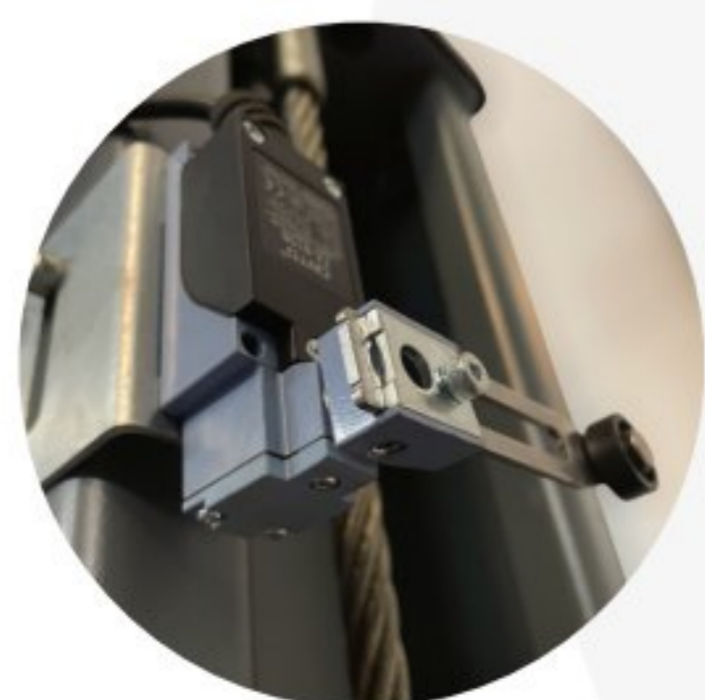

ES: Escanee el código para más información.

FR: Scannez le code pour plus d'informations.

EN: Scan the code for further information.

IT: Scansiona il codice per maggiori informazioni.



Königstein

5T

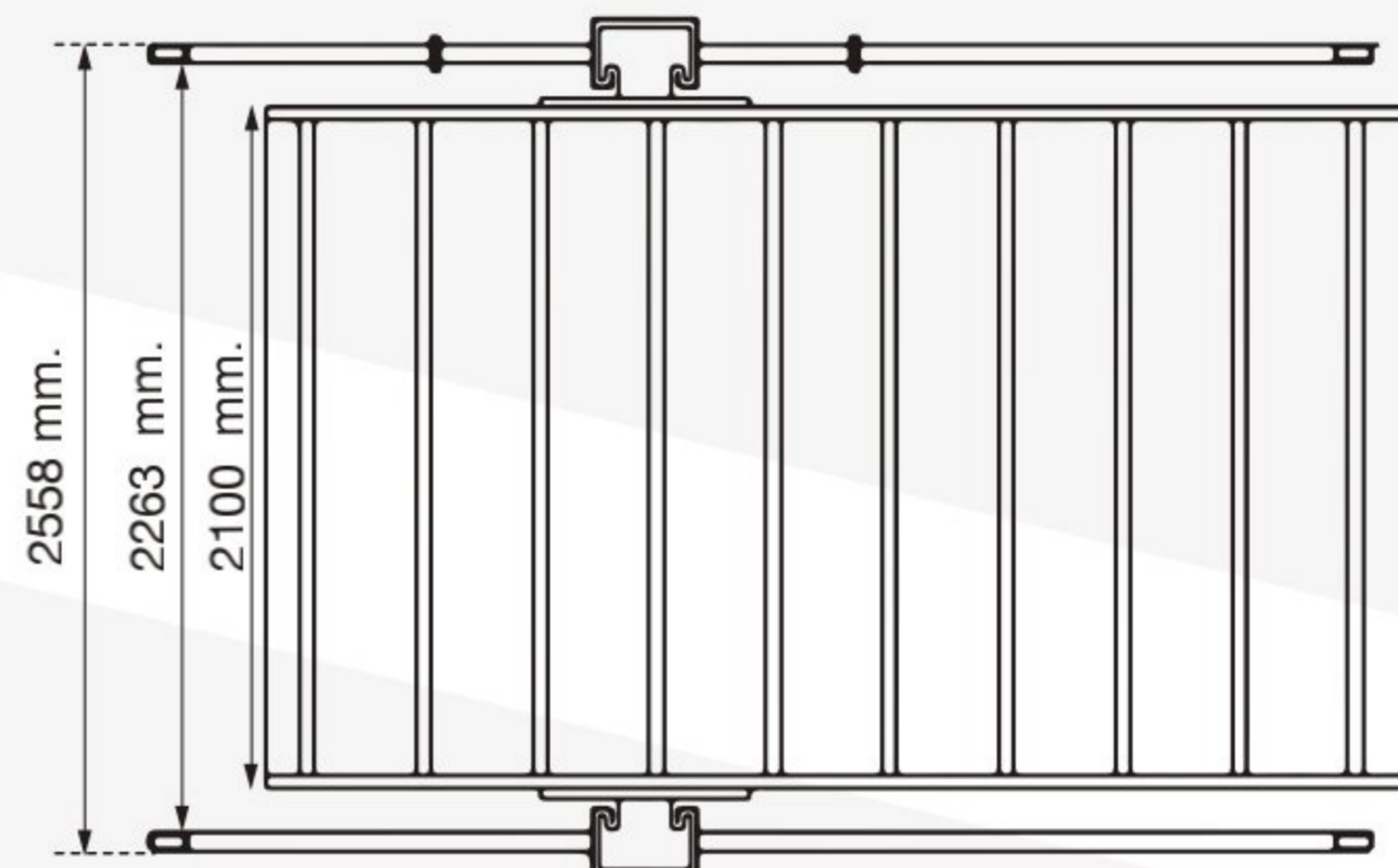
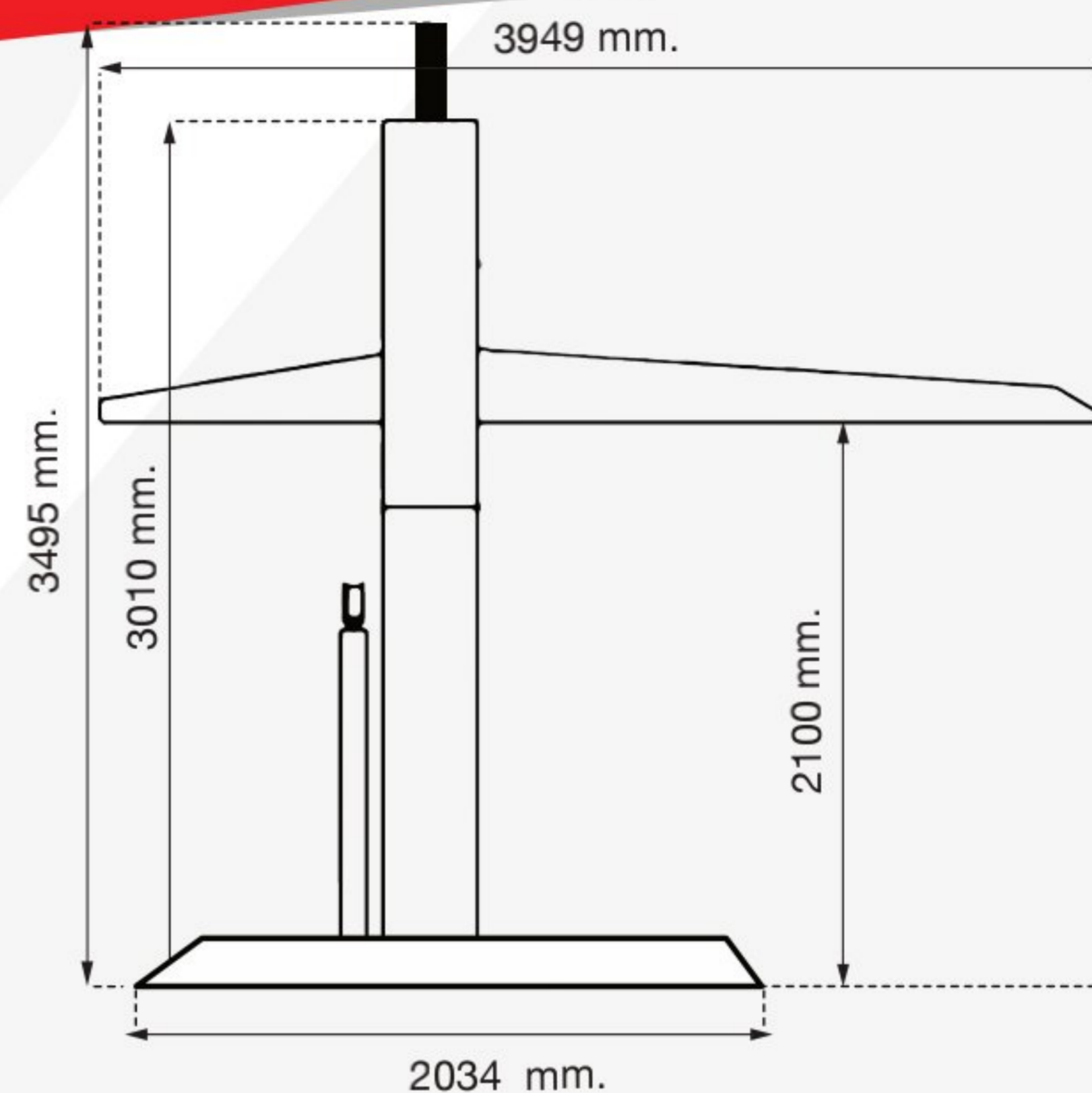
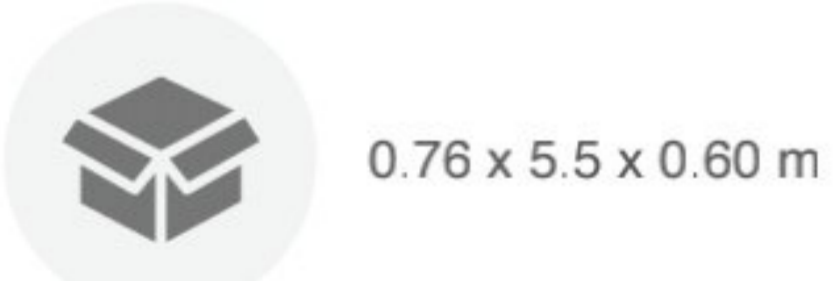
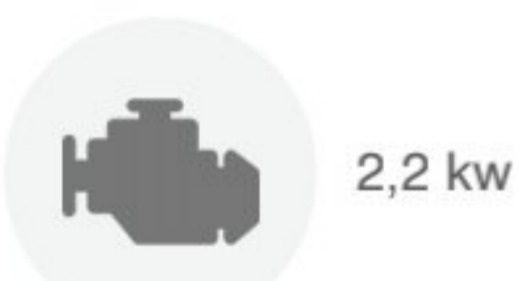
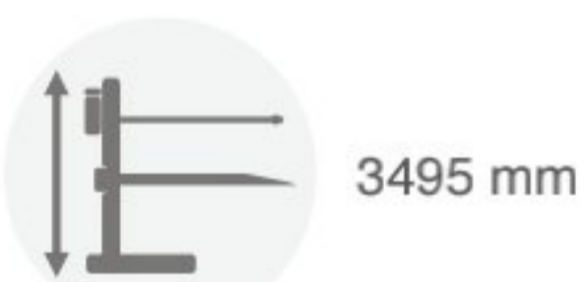
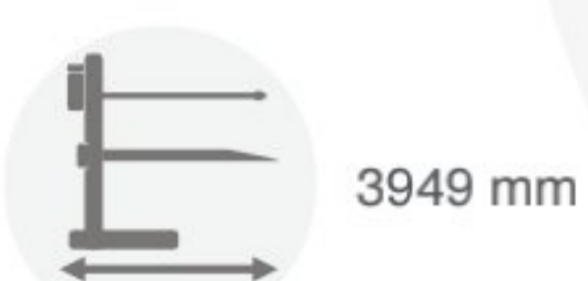
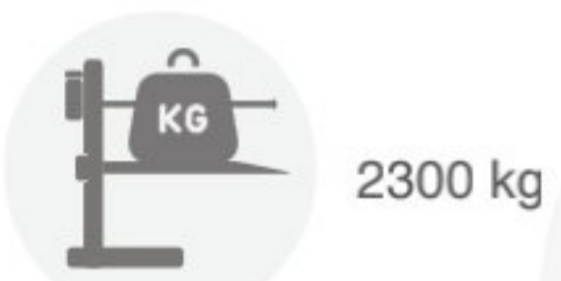

ELEVADOR DE PARKING

- Su estructura permite múltiples instalaciones en espacios reducidos. Las estructuras de elevación son independientes. Alarma visual y sonora durante el accionamiento. Activado por llave del motor e interruptor
- Botón de parada de emergencia para seguridad del operador.

PARKING LIFT

- Sa structure permet de multiples installations dans de petits espaces. Les structures de levage sont indépendantes. Alarme visuelle et sonore lors de l'activation. Activé par la clé du moteur et l'interrupteur
- Bouton d'arrêt d'urgence pour la sécurité de l'opérateur.

PARKING PONT ÉLÉVATEUR

- Its structure allows multiple installations in small spaces. The lifting structures are independent. Visual and audible alarm during activation. Activated by engine key and switch
- Emergency stop button for operator safety.

SOLLEVATORE PER PARKING

- La sua struttura permette installazioni multiple in piccoli spazi. Le strutture di sollevamento sono indipendenti. Allarme visivo e acustico durante l'attivazione. Attivato da chiave motore e interruttore
- Pulsante di arresto di emergenza per la sicurezza dell'operatore.

KN3L7



ES: Escanee el código para más información.

FR: Scannez le code pour plus d'informations.

EN: Scan the code for further information.

IT: Scansiona il codice per maggiori informazioni.



NOTA: Las imágenes mostradas tienen el propósito de representar el producto solamente y pueden variar dependiendo del modelo y stock



12" - 24"



10" - 22"



12"



2800 kg



1.1 kw / 0.75kw



(3 ~) 380V







1.15 m x 0.95 m x 0.98 m



187 kg



-  Brazo de ayuda incluido
-  Bras d'assistance incluse
-  Help arm included
-  Con braccio di sostegno

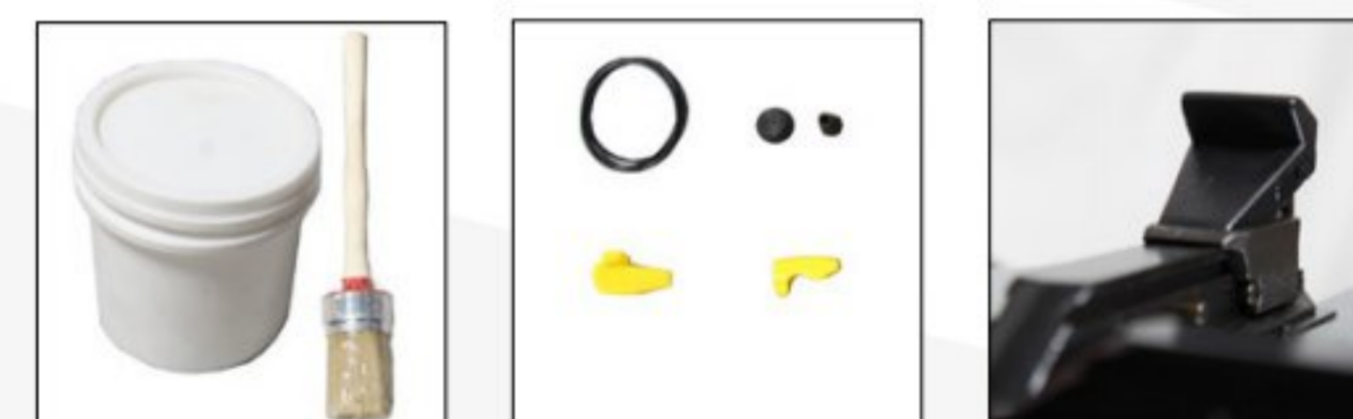
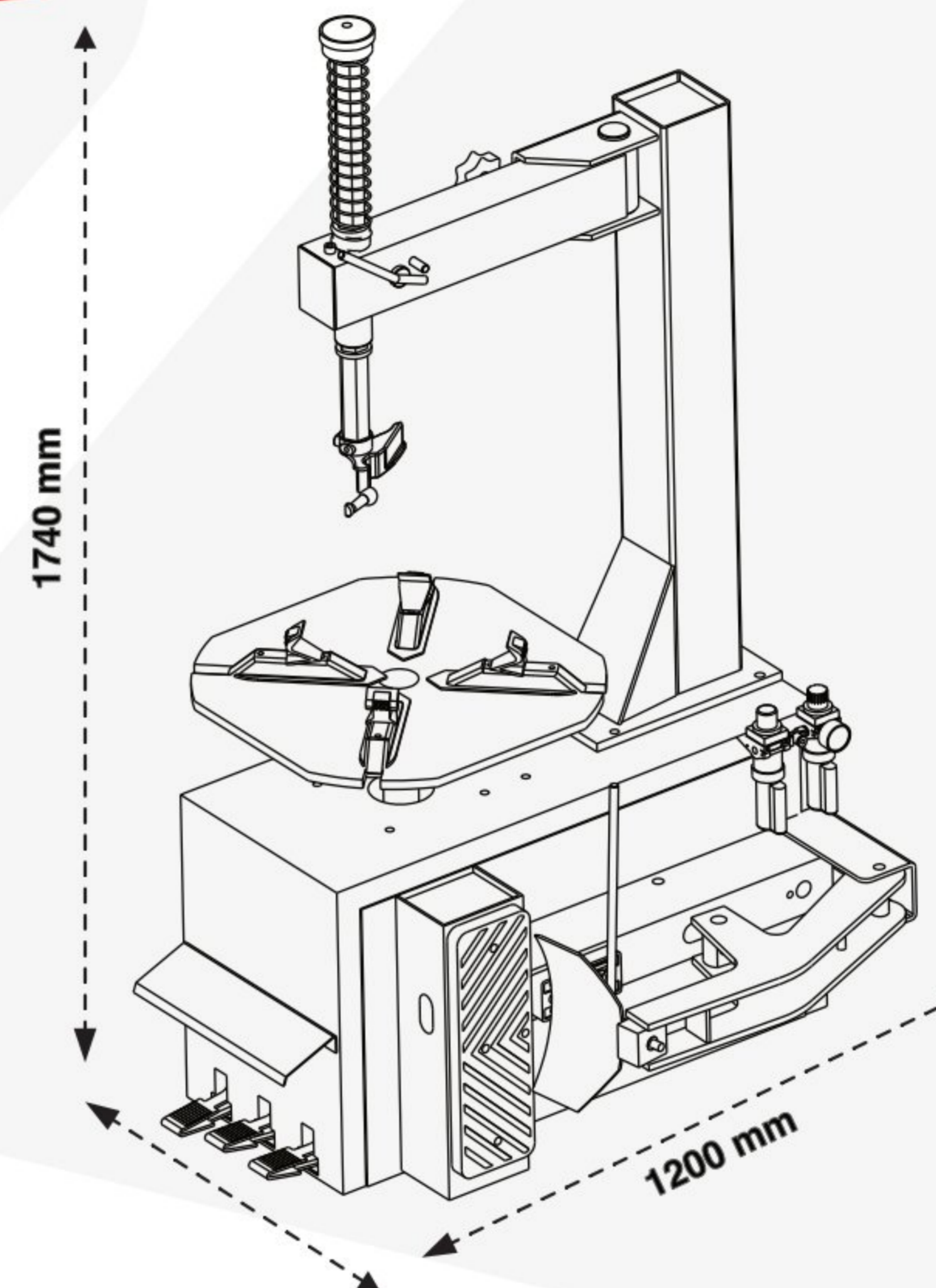

ES: Escanee el código para más información.

FR: Scannez le code pour plus d'informations.

EN: Scan the code for further information.

IT: Scansiona il codice per maggiori informazioni.



DESMONTADORA DE NEUMÁTICOS SEMI-AUTOMÁTICA

- Desmontadora de neumáticos con palanca de ayuda.
- Soporte para el lubricante, regulable en diámetro.
- Sistema de 4-centradores automáticos con dos cilindros neumáticos.

DÉMONTE-PNEU SEMI-AUTOMATIQUE

- Démonte-pneus avec levier d'assistance.
- Support pour le lubrifiant, réglable en diamètre.
- Système de 4 dispositifs de centrage automatique avec deux cylindres pneumatiques.

TIRE CHANGER SEMI AUTOMATIC

- Tyre changer with assist lever
- Support for lubricant, adjustable in diameter.
- Automatic 4-centering system with two pneumatic cylinders

SMONTAGOMME SEMIAUTOMATICO

- Smontagomme con assistenza a leva.
- Supporto per il lubrificante, regolabile in diametro.
- Sistema di 4-centratori automatici con due cilindri pneumatici.





12" - 24"



10" - 22"



13"



2800 kg



1.1 kw / 0.75kw



(3 ~) 380V







1.15 m x 0.95 m x 0.98 m



255 kg



-  Trae incluido de serie el brazo mecánico roller.
-  Est livrée en standard avec le bras mécanique roller
-  Mechanical roller arm included
-  Include nel pacchetto il braccio meccanico Roller

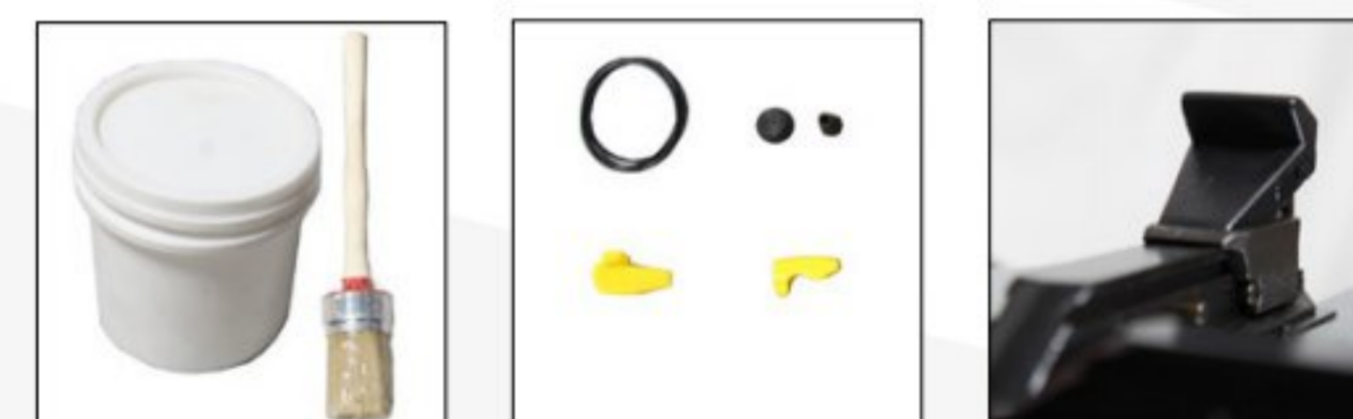
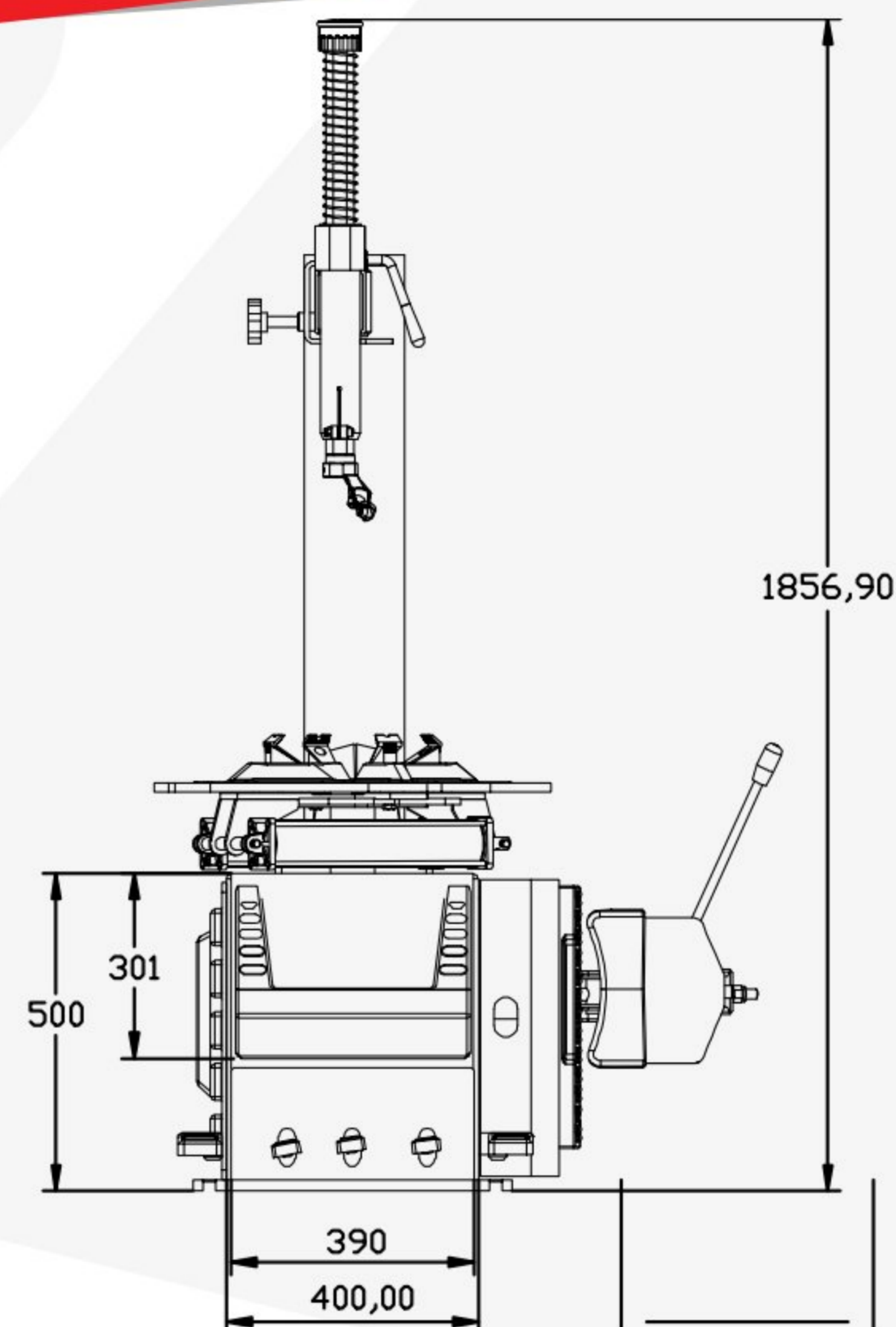

DESMONTADORA DE NEUMÁTICOS SEMI-AUTOMÁTICA

- Desmontadora de neumáticos con palanca de ayuda.
- Soporte para el lubricante, regulable en diámetro.
- Sistema de 4-centradores automáticos con dos cilindros neumáticos.

DÉMONTE-PNEU SEMI-AUTOMATIQUE

- Démonte-pneus avec levier d'assistance.
- Support pour le lubrifiant, réglable en diamètre.
- Système de 4 dispositifs de centrage automatique avec deux cylindres pneumatiques.

TIRE CHANGER SEMI AUTOMATIC

- Tyre changer with assist lever
- Support for lubricant, adjustable in diameter.
- Automatic 4-centering system with two pneumatic cylinders

SMONTAGOMME SEMIAUTOMATICO

- Smontagomme con assistenza a leva.
- Supporto per il lubrificante, regolabile in diametro.
- Sistema di 4-centratori automatici con due cilindri pneumatici.

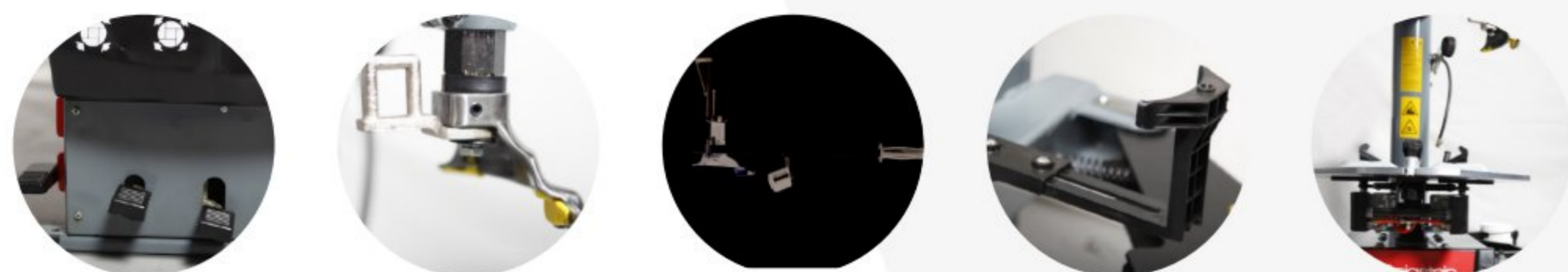

ES: Escanee el código para más información.

FR: Scannez le code pour plus d'informations.

EN: Scan the code for further information.

IT: Scansiona il codice per maggiori informazioni.





12" - 26"



9" - 24"



3 - 13"



2900 kg



0.75kw



(3 ~) 380V



1.15 x 0.95 x 1.1 m



250 / 270 kg



KN120

KN120 PLUS

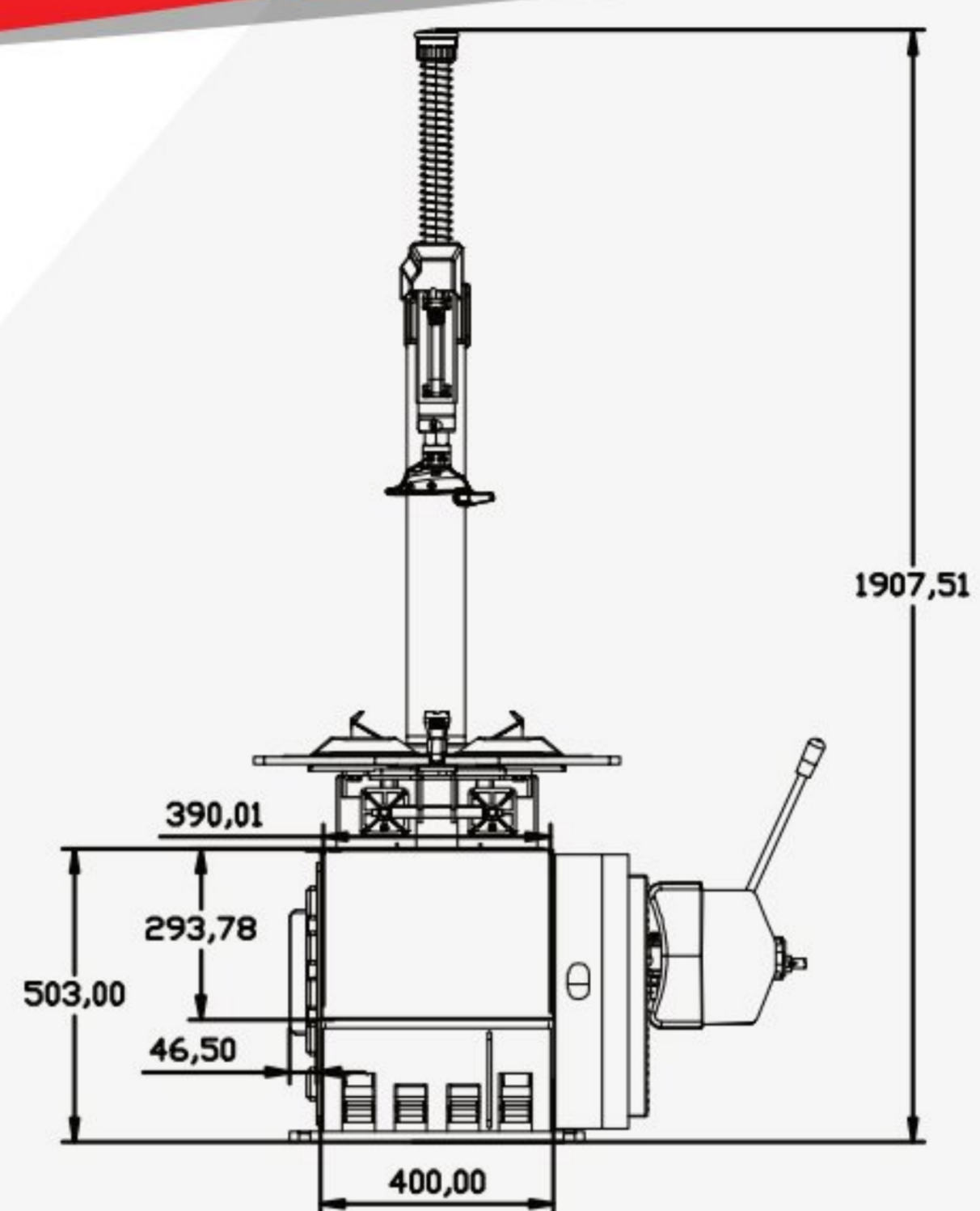

Modelo Plus: Revestimientos y carcasas de polimero, Sistema de inflado, Sistema, Doble Velocidad.

Modèle Plus: Revêtements et boîtiers en polymère, Système de gonflage Tubeless, Système, Double Vitesse.

Model Plus: Plastic covering and case, Tubeless system, Double speed system.

Modelli Plus: Rivestimenti e custodie in polimero, Sistema di gonfiaggio Tubeless, Sistema Velocità doppia

DESMONTADORA DE NEUMÁTICOS AUTOMÁTICA

- Desmontadora de neumáticos con palanca de ayuda.
- Soporte para el lubricante, regulable en diámetro.
- Sistema de 4-centradores automáticos con dos cilindros neumáticos.

DÉMONTE-PNEU AUTOMATIQUE

- Démonte-pneus avec levier d'assistance.
- Support pour le lubrifiant, réglable en diamètre.
- Système de 4 dispositifs de centrage automatique avec deux cylindres pneumatiques.

TIRE CHANGER AUTOMATIC

- Tyre changer with assist lever
- Support for lubricant, adjustable in diameter.
- Automatic 4-centering system with two pneumatic cylinders

SMONTAGOMME AUTOMATICO

- Smontagomme con assistenza a leva.
- Supporto per il lubrificante, regolabile in diametro.
- Sistema di 4-centratori automatici con due cilindri pneumatici.

KN120 - KN120+

Königstein

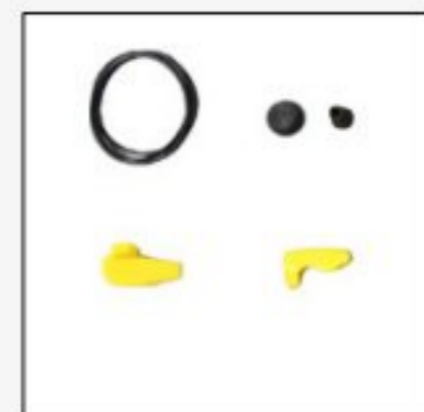

ES: Escanee el código para más información.

FR: Scannez le code pour plus d'informations.

EN: Scan the code for further information.

IT: Scansiona il codice per maggiori informazioni.



NOTA: Las imágenes mostradas tienen el propósito de representar el producto solamente y pueden variar dependiendo del modelo y stock



12" - 26"



9" - 24"



3 - 13"



2900 kg



0.75kw



(3 ~) 380V



1.15 x 0.95 x 1.10 m

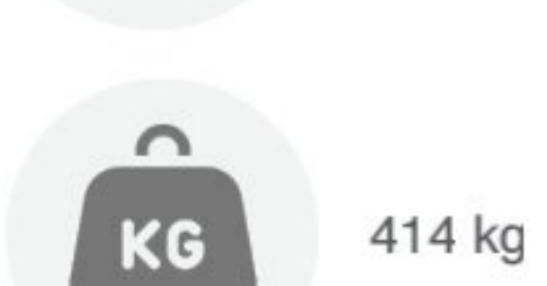

414 kg



- Brazo de ayuda KN120BDA
- Sistema de inflado Tubeless
- Doble velocidad
- Uña automática de desmontaje
- Revestimientos y carcasas de polimero que la protegen y embellecen.



- Bras auxiliaire KN120BDA
- Système de gonflage Tubeless
- Double vitesse
- Griffe de démontage automatique
- Revêtements et boîtiers en polymère qui protègent et agrémentent l'ensemble.



- Help arm KN120BDA
- Tubeless system
- Double speed
- Bead breaker automatic claw
- Polimery covering and case to protect it from damages



- Braccio di sostegno KN120BDA
- Sistema di gonfiaggio Tubeless
- Doppia velocità
- Torretta automatica di smontaggio
- Rivestimenti e custodie in polimero che la proteggono e abbelliscono.



DESMONTADORA DE NEUMÁTICOS AUTOMÁTICA

- Desmontadora de neumáticos con palanca de ayuda.
- Soporte para el lubricante, regulable en diámetro.
- Sistema de 4-centradores automáticos con dos cilindros neumáticos.



DÉMONTE-PNEU AUTOMATIQUE

- Démonte-pneus avec levier d'assistance.
- Support pour le lubrifiant, réglable en diamètre.
- Système de 4 dispositifs de centrage automatique avec deux cylindres pneumatiques.



TIRE CHANGER AUTOMATIC

- Tyre changer with assist lever
- Support for lubricant, adjustable in diameter.
- Automatic 4-centering system with two pneumatic cylinders



SMONTAGOMME AUTOMATICO

- Smontagomme con assistenza a leva.
- Supporto per il lubrificante, regolabile in diametro.
- Sistema di 4-centratori automatici con due cilindri pneumatici.

KN1208

Königstein

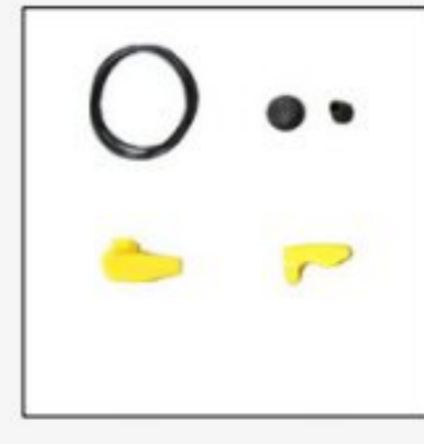

ES: Escanee el código para más información.

FR: Scannez le code pour plus d'informations.

EN: Scan the code for further information.

IT: Scansiona il codice per maggiori informazioni.





12" - 26"



9" - 26"



3 - 13"



2900 kg

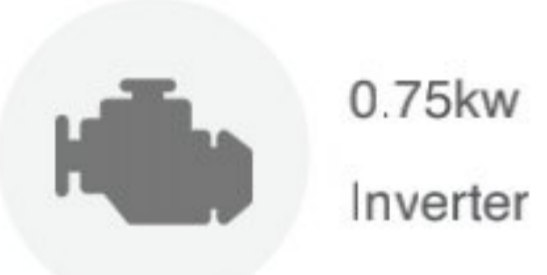

0.75kw
Inverter



(1 ~) 220V
Inverter

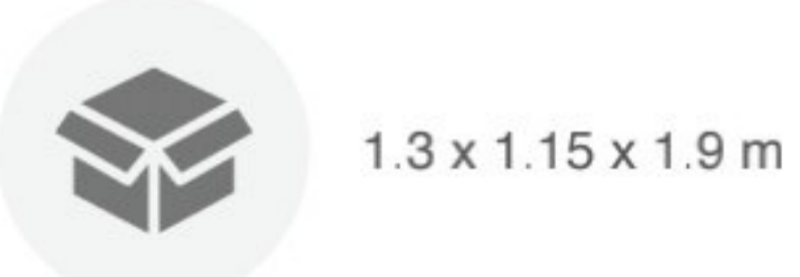

1.3 x 1.15 x 1.9 m

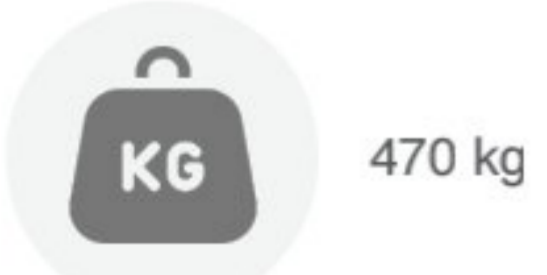

470 kg



KN129

Königstein

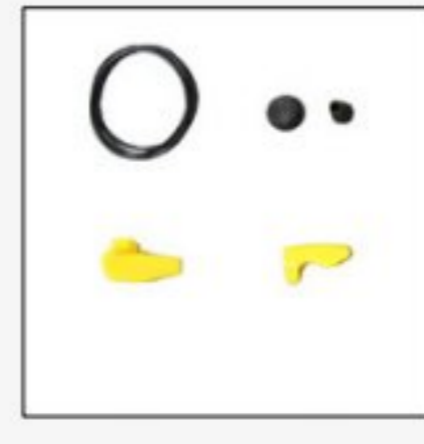

- Brazo de ayuda KN120BDA
- Motor inverter
- Velocidad progresiva
- Uña automática de desmontaje
- Revestimientos y carcasas de polimero que la protegen y embellecen.



- Bras auxiliaire KN120BDA
- Moteur inverseur
- Vitesse progressive
- Griffe de démontage automatique
- Revêtements et boîtiers en polymère qui protègent et agrémentent l'ensemble.



- Help arm KN120BDA
- Inverter motor
- Progressive speed
- Bead breaker automatic claw
- Polimery covering and case to protect it from damages



- Braccio di sostegno KN120BDA
- Motore inverter
- Velocità progressiva
- Torretta automatica di smontaggio
- Rivestimenti e custodie in polimero che la proteggono e abbelliscono.



DESMONTADORA DE RUEDAS AUTOMÁTICA CON BRAZO DE AYUDA, UÑA AUTOMÁTICA Y VELOCIDAD PROGRESIVA

- Sistema tubeless incorporado (tanque de inflado automático)
- Dispositivo tensor mecánico para el brazo de montaje
- Cabezal giratorio



DÉMONTE-PNEU AUTOMATIQUE AVEC BRAS D'ASSISTANCE INCLUS ET VITESSE PROGRESSIVE

- Système tubeless intégré (réservoir de gonflage automatique)
- Dispositif de tension mécanique pour bras de montage



TYRE CHANGING MACHINE - AUTOMATIC WITH HELP ARM INCLUDED, AUTOMATIC CLAW AND PROGRESSIVE SPEED

- Leverless tyre changer with pneumatic swing arm
- The streamlined design makes machine more attractive



SMONTAGOMME AUTOMATICA - BRACCIO DI SOSTEGNO INCLUSO

- Sistema tubeless incorporato (serbatoio di gonfiaggio automatico)
- Dispositivo di tensione meccanico per il braccio di montaggio



ES: Escanee el código para más información.

FR: Scannez le code pour plus d'informations.

EN: Scan the code for further information.





IT: Scansiona il codice per maggiori informazioni.



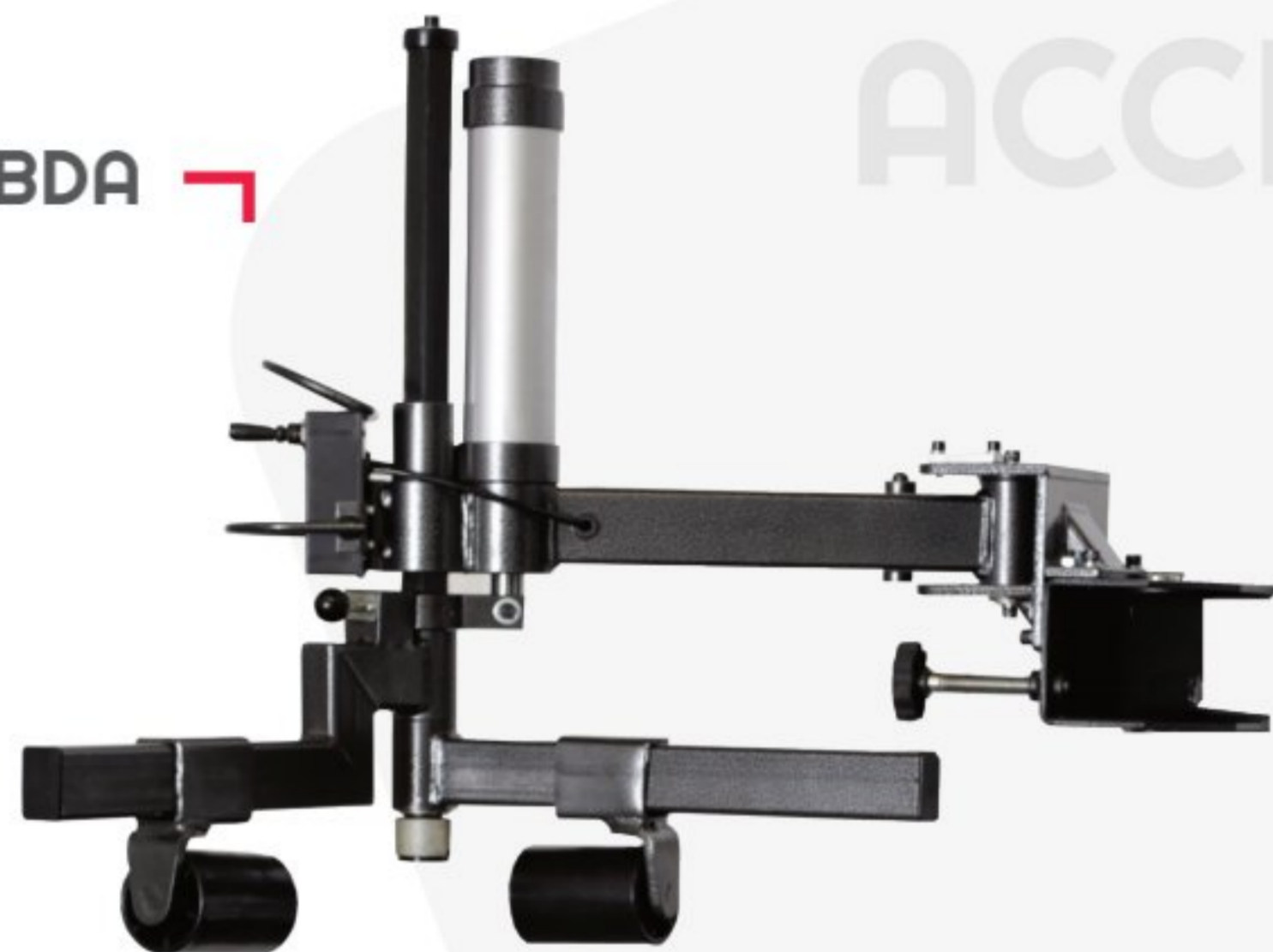



ACCESORIOS
ACCESSOIRES

KN110BDA



-  Brazo de ayuda para KN110
-  Bras auxiliaire pour KN110
-  Help arm, ideal for KN110
-  Braccio di sostegno per KN110

-  Brazo de ayuda para KN120
-  Bras auxiliaire pour KN120
-  Help arm, ideal for KN120
-  Braccio di sostegno per KN120

KN120BDA



KN120 PLUS
KN120BDA



KN120
KN120BDA



KN110
KN110BDA



ACCESSORI



ES: Escanee el código para más información.

EN: Scan the code for further information.

FR: Scannez le code pour plus d'informations.

IT: Scansiona il codice per maggiori informazioni.



Königstein



12" - 26"



1100 mm



1.5 - 12"



0.25kw



(1 ~) 220V



0.90 x 0.75 x 1.16 m



160 kg

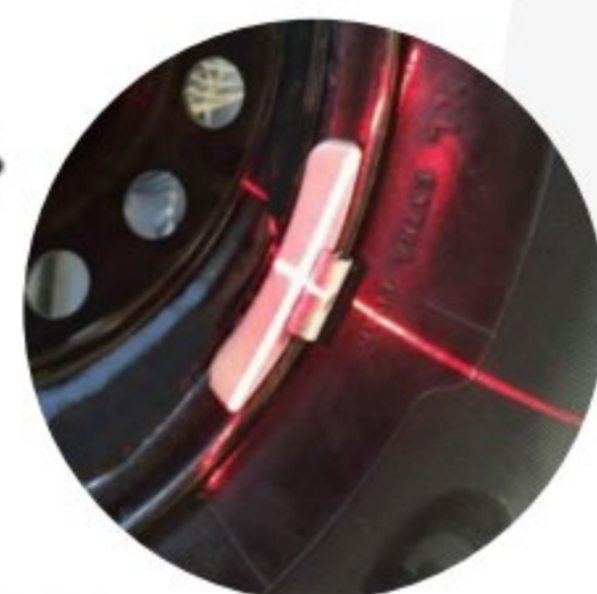

Alta precisión, Fácil de operar, Fácil de montar.

Haute précision, Facile à utiliser, Facile à assembler.

High accuracy, Easy to use, Easy to assemble.

Alta precisione, Facile da utilizzare, Facile da montare.

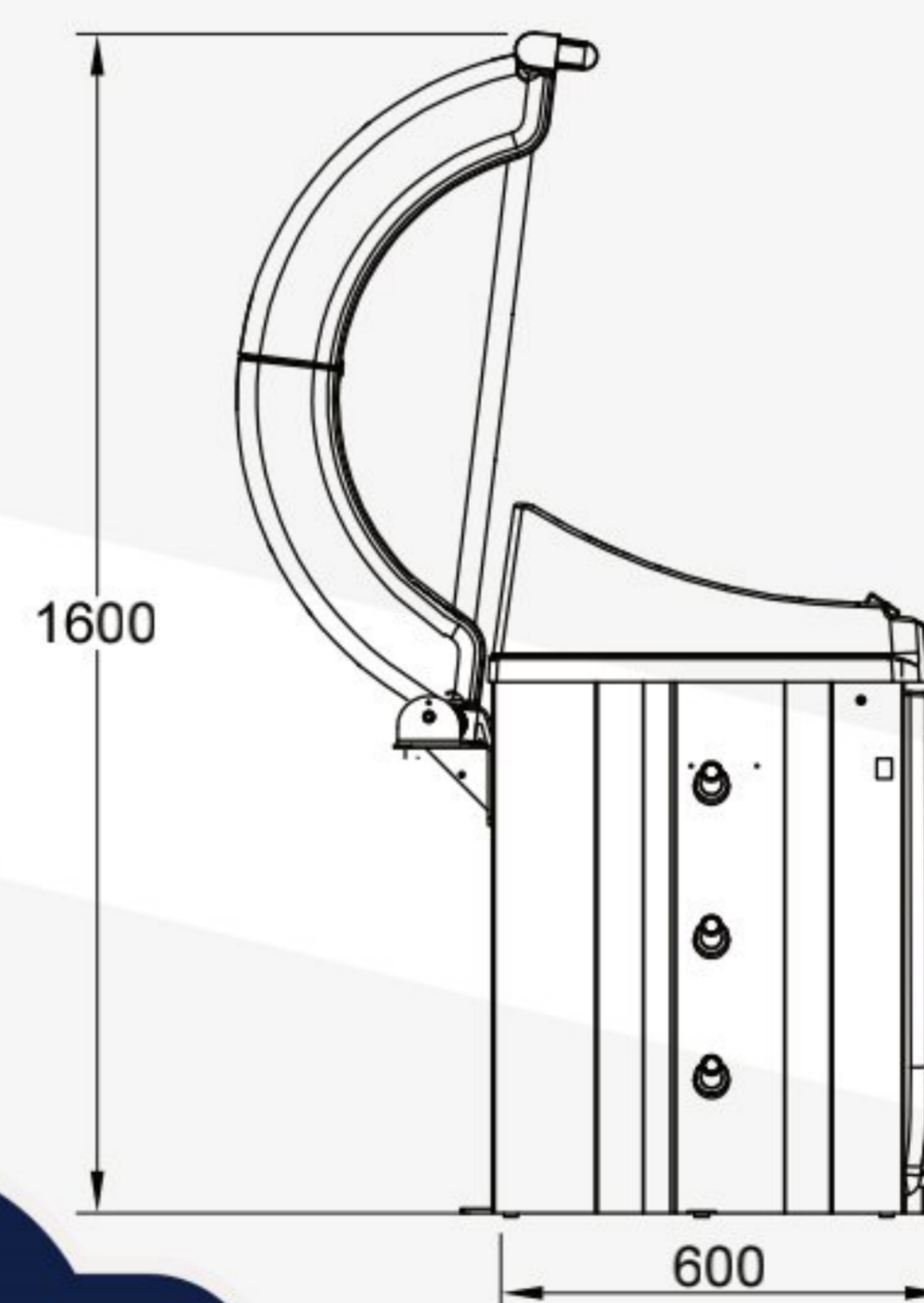
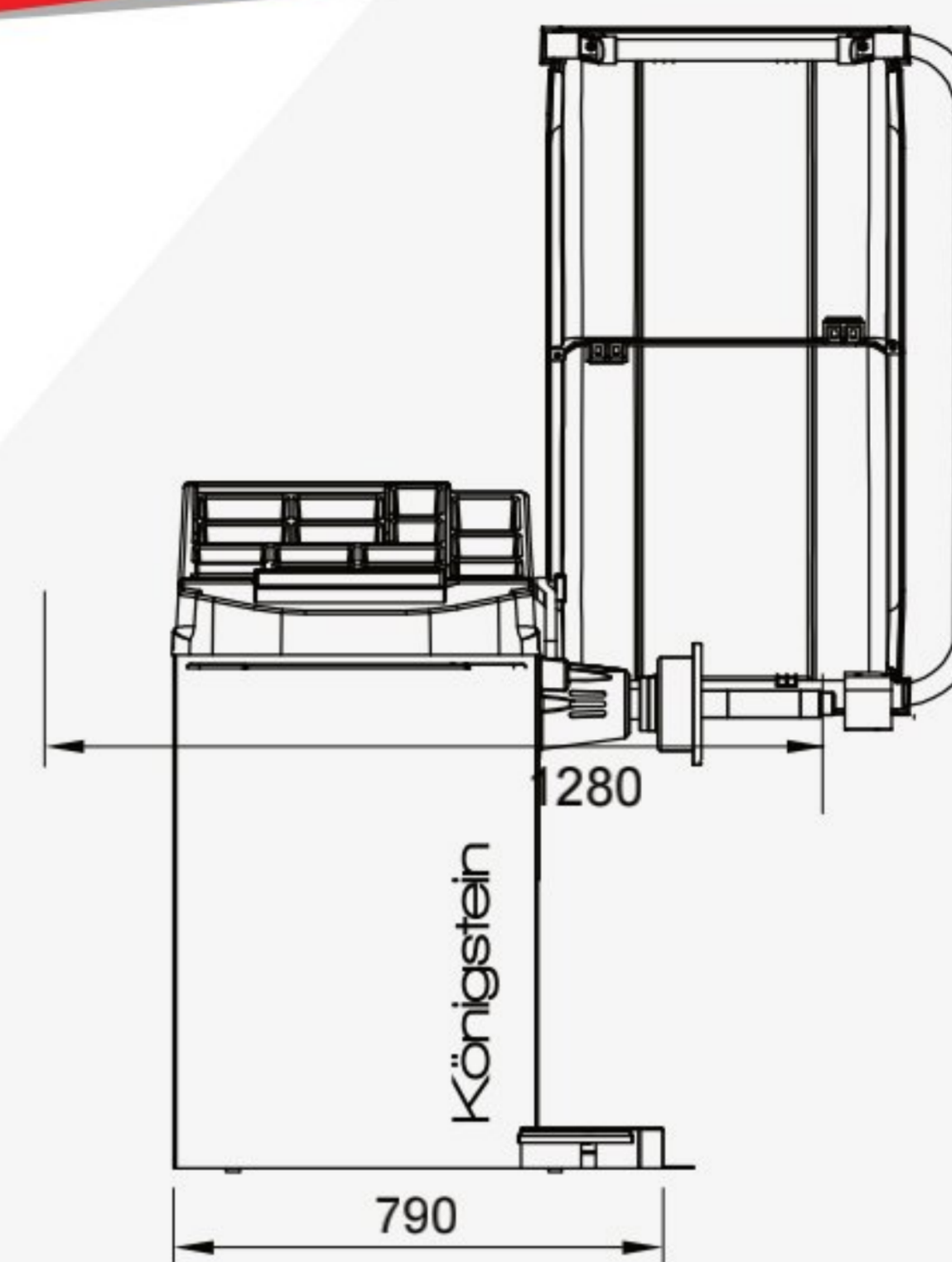

EQUILBRADORA PARA RUEDAS DE 12"- 24" CON LASER

- Función de medición dinámica y estática.
- Función de auto-calibración
- Modos de medición ALU 1,2 y 3 dinámico y estático.
- Sistema de operación geométrico

EQUILIBREUSE MESURE AUTOMATIQUE POUR ROUES DE 12"- 24"

- Fonction de mesure dynamique et statique.
- Fonction d'auto-calibration
- Modes de mesure ALU 1,2 y 3 dynamique et statique.
- Système de géométrie

BASIC PROFESSIONAL BALANCER IDEAL FOR 12"- 24" WHEELS

- Dynamic and static measurement
- Self-calibration
- ALU 1,2 y 3 dynamic and static program.
- Geometric operating system

EQUILIBRATRICE BASICA PROFESSIONALE PER RUOTE DI 12"- 24"

- Funzione di misurazione dinamica e statica.
- Funzione di auto-calibrazione
- Modalità misurazione ALU 1,2 e 3, dinamica e statica.
- Sistema di operazione geometrica.

KN200

Königstein



Localice los accesorios dentro de la máquina

Les accessoires se trouvent dans une tiroir située en bas à l'intérieur de la machine

Find the accessories inside the machine

Gli accessori sono situati nel cassetto in fondo alla macchina

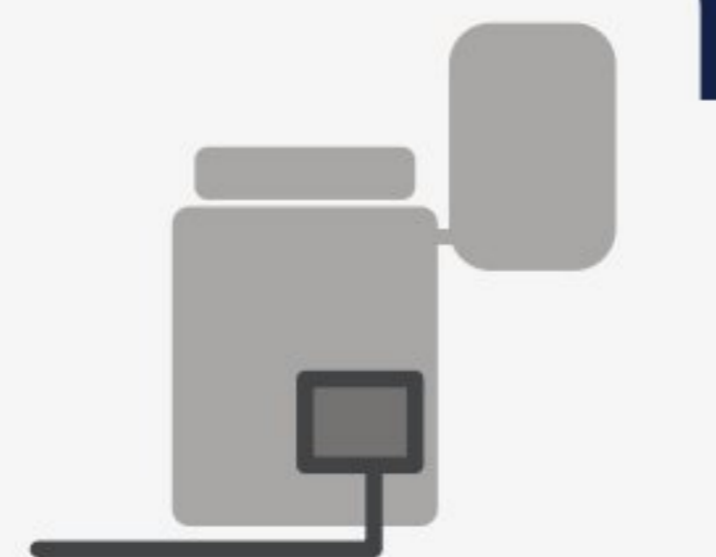

ES: Escanee el código para más información.

FR: Scannez le code pour plus d'informations.

EN: Scan the code for further information.

IT: Scansiona il codice per maggiori informazioni.



NOTA: Las imágenes mostradas tienen el propósito de representar el producto solamente y pueden variar dependiendo del modelo y stock



12" - 24"



800 mm



1.5 - 20"



0.25kw



(1 ~) 220V



1.15 x 0.95 x 0.98 m



146 kg



- Alta precisión, Fácil de operar, Fácil de montar.
- Haute précision, Facile à utiliser, Facile à assembler.
- High accuracy, Easy to use, Easy to assemble.
- Alta precisione, Facile da utilizzare, Facile da montare.

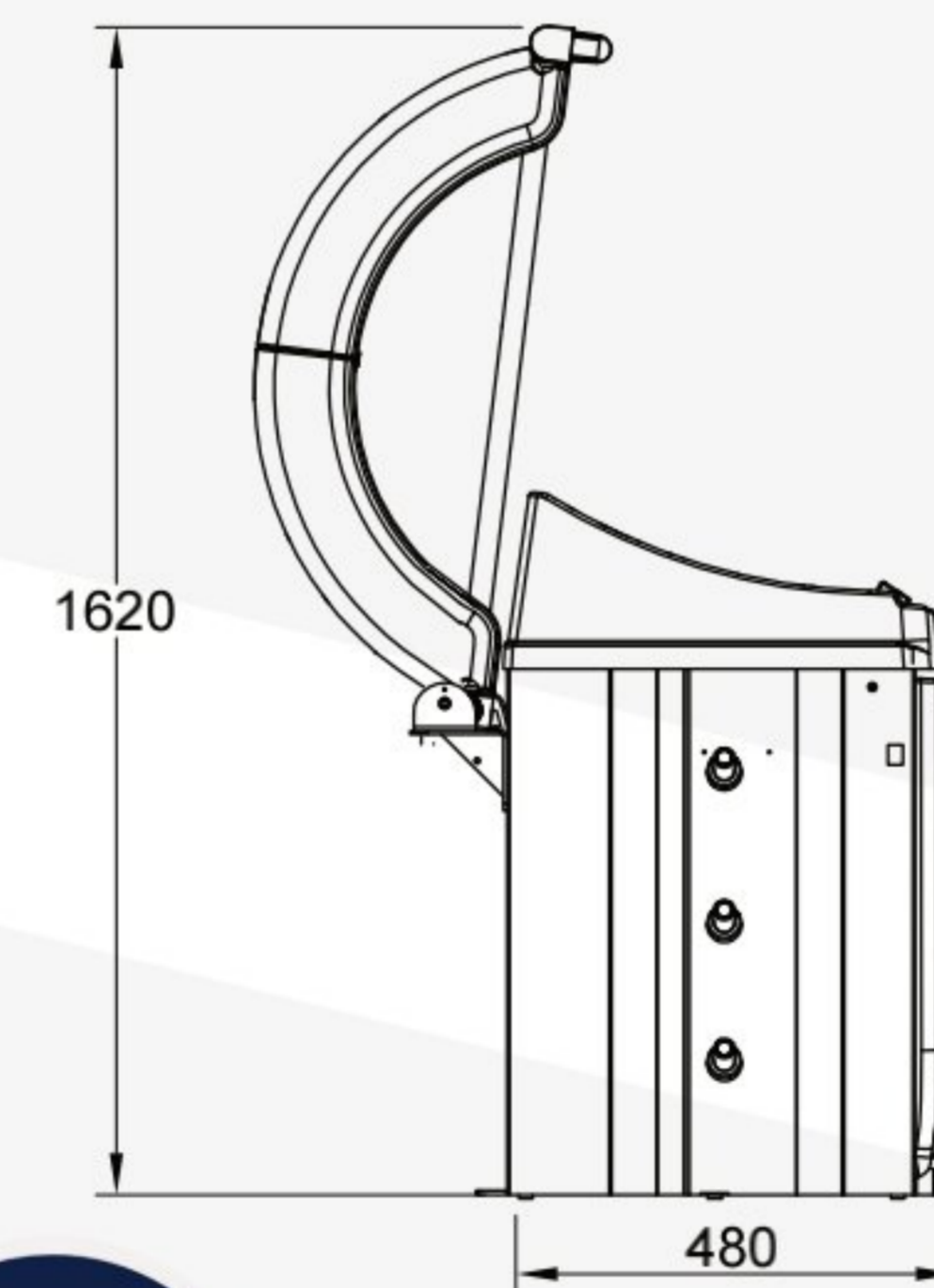
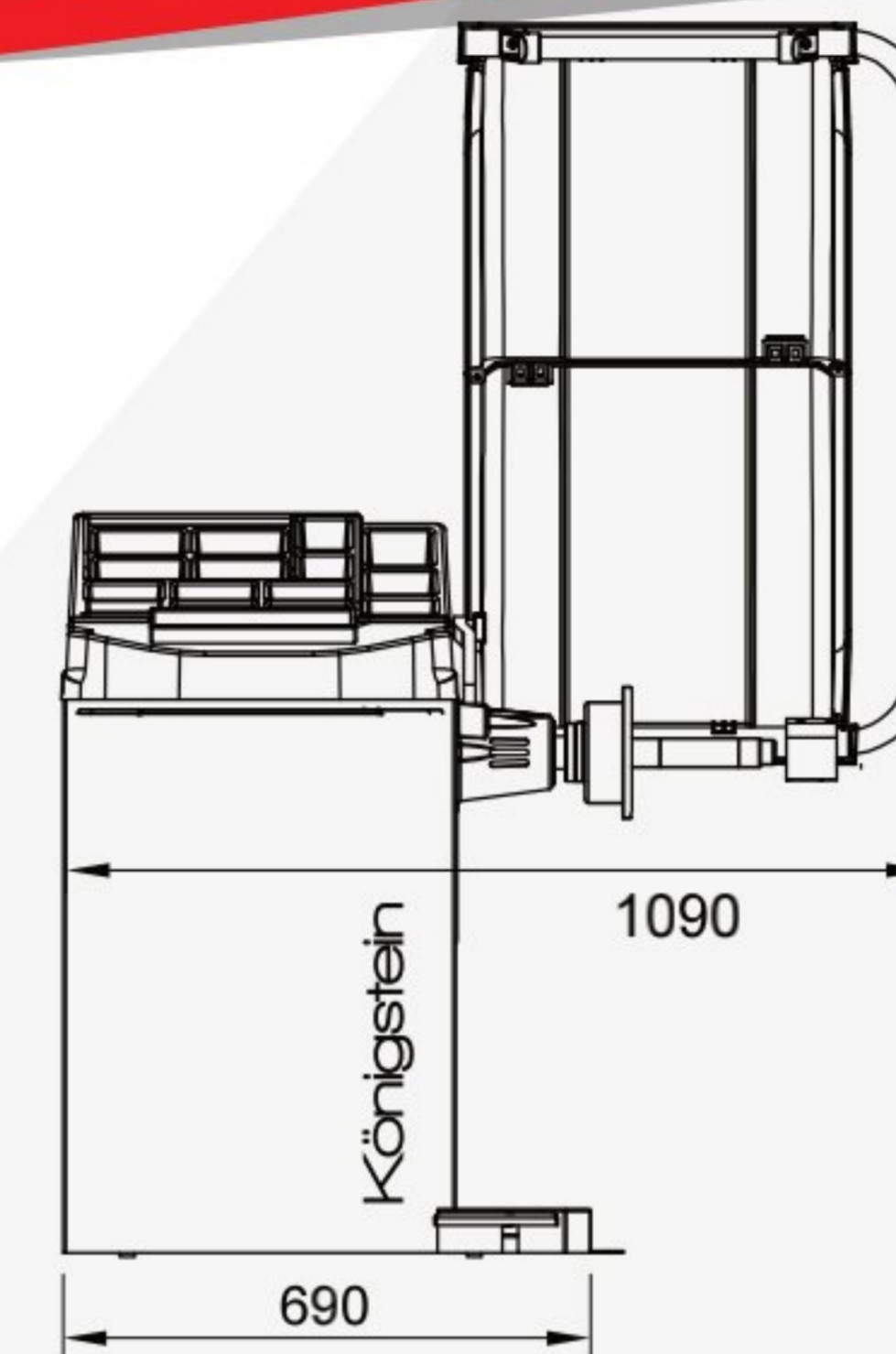

EQUILBRADORA PARA RUEDAS DE 12"- 24"

- Función de medición dinámica y estática.
- Función de auto-calibración
- Modos de medición ALU 1,2 y 3 dinámico y estático.
- Sistema de operación geométrico

EQUILIBREUSE MESURE AUTOMATIQUE POUR ROUES DE 12"- 24"

- Fonction de mesure dynamique et statique.
- Fonction d'auto-calibration
- Modes de mesure ALU 1,2 y 3 dynamique et statique.
- Système de géométrie

BASIC PROFESSIONAL BALANCER IDEAL FOR 12"- 24" WHEELS

- Dynamic and static measurement
- Self-calibration
- ALU 1,2 y 3 dynamic and static program.
- Geometric operating system

EQUILIBRATRICE BASICA PROFESSIONALE PER RUOTE DI 12"- 24"

- Funzione di misurazione dinamica e statica.
- Funzione di auto-calibrazione
- Modalità misurazione ALU 1,2 e 3, dinamica e statica.
- Sistema di operazione geometrica.

KN224

Königstein



- Localice los accesorios dentro de la máquina
- Les accessoires se trouvent dans une tiroir située en bas à l'intérieur de la machine
- Find the accessories inside the machine
- Gli accessori sono situati nel cassetto in fondo alla macchina

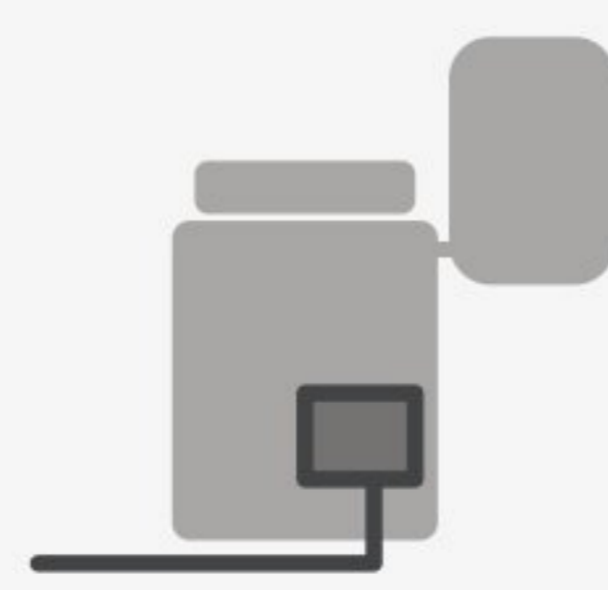

ES: Escanee el código para más información.

FR: Scannez le code pour plus d'informations.





EN: Scan the code for further information.

IT: Scansiona il codice per maggiori informazioni.



-  12"- 24"
-  800 mm
-  1.5 - 20"
-  0.25kw
-  (1 ~) 220V
-  0.90 x 0.75 x 1.16 m
-  150 kg



-  Alta precisión, Fácil de operar, Fácil de montar.
-  Haute précision, Facile à utiliser, Facile à assembler.
-  High accuracy, Easy to use, Easy to assemble.
-  Alta precisione, Facile da utilizzare, Facile da montare.

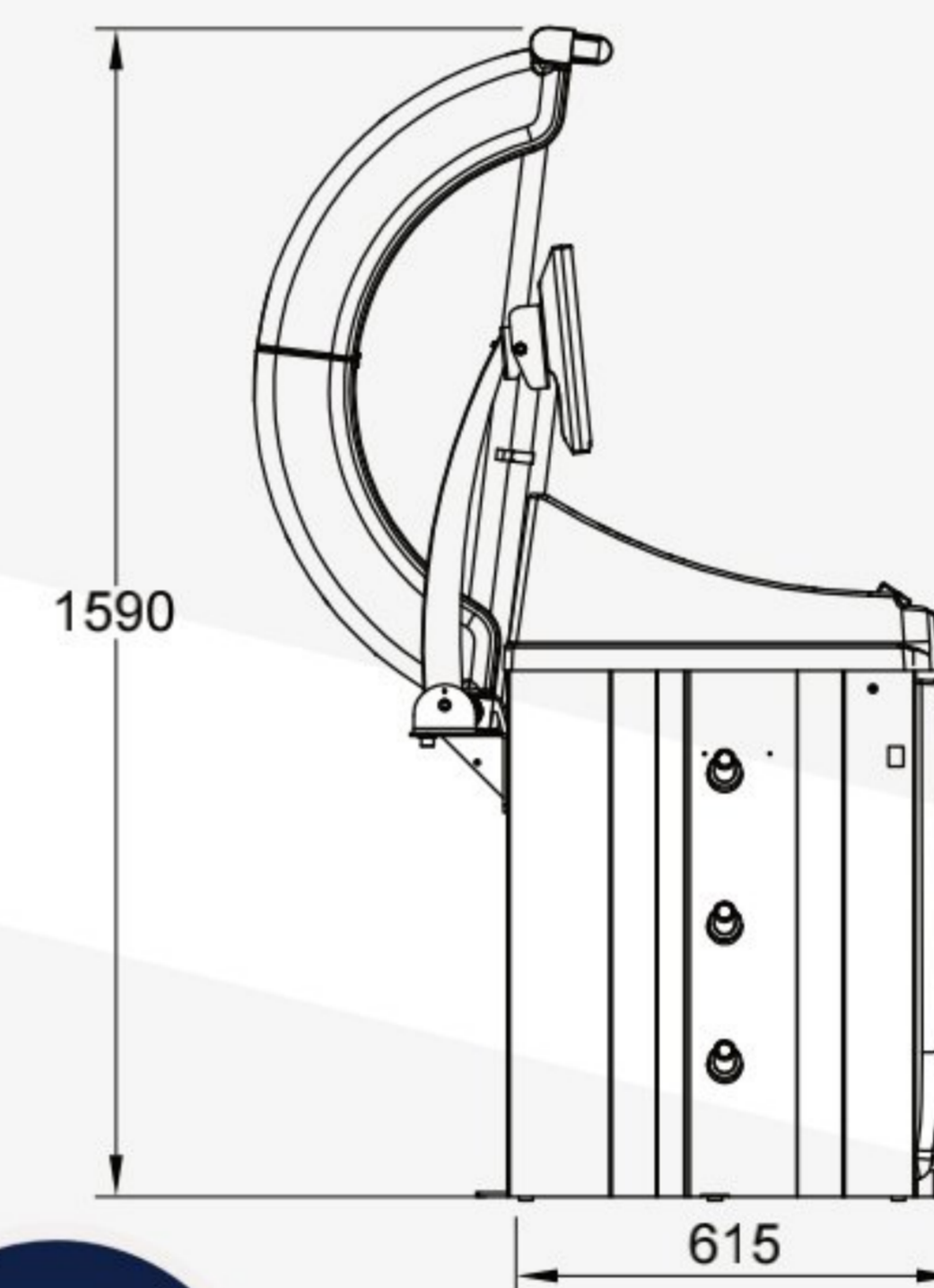
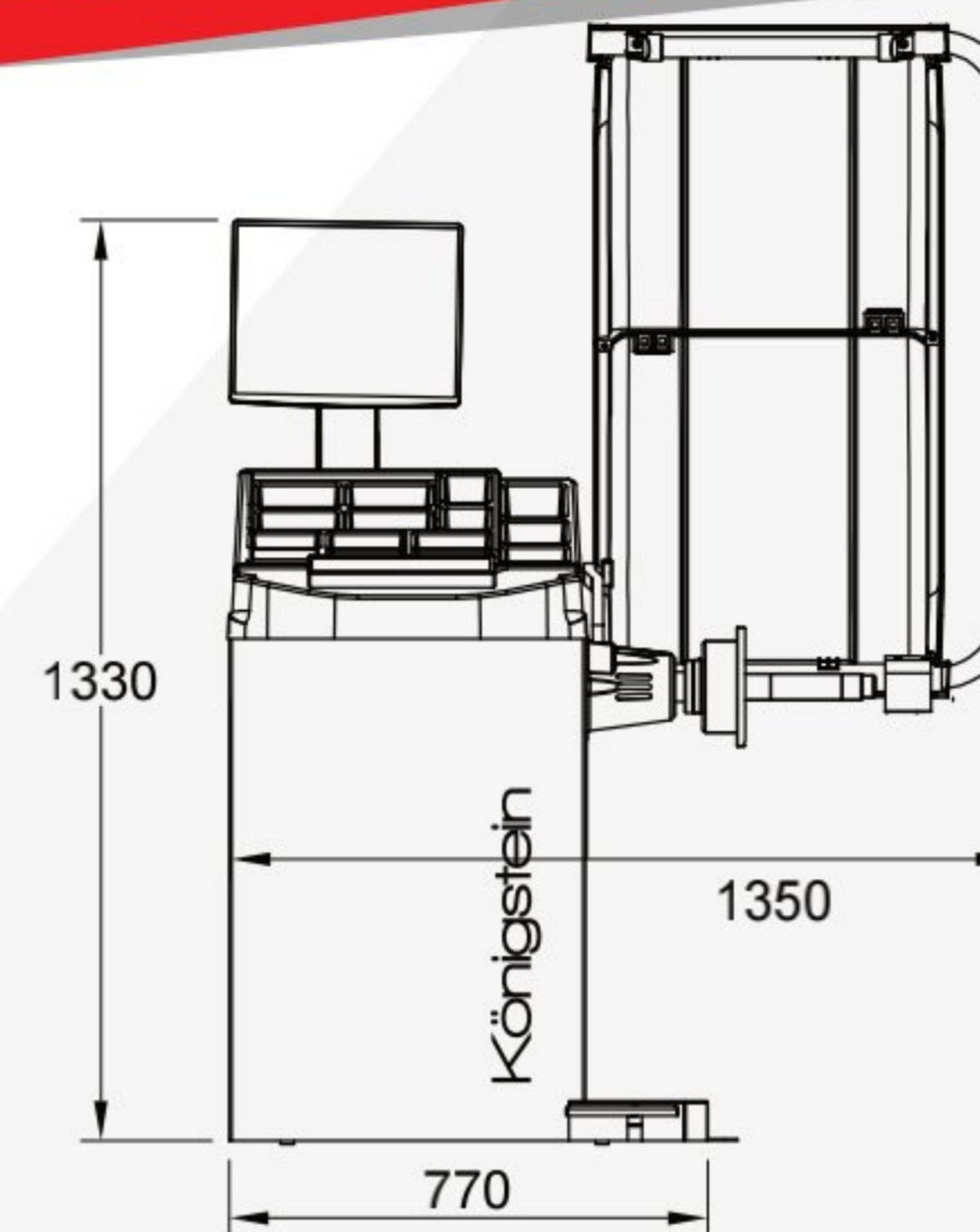

EQUILBRADORA AUTOMÁTICA PROFESIONAL PARA RUEDAS DE 12"- 24"

- Función de medición dinámica y estática.
- Función de auto-calibración
- Modos de medición ALU 1,2 y 3 dinámico y estático.
- Sistema de operación geométrico

ÉQUILIBREUSE PROFESSIONNELLE AUTOMATIQUE POUR ROUES DE 12"- 24"

- Fonction de mesure dynamique et statique.
- Fonction d'auto-calibration
- Modes de mesure ALU 1,2 y 3 dynamique et statique.
- Système de géométrie

AUTOMATIC PROFESSIONAL WHEEL BALANCER 12"- 24" WHEELS.

- Dynamic and static measurement
- Self-calibration
- ALU 1,2 y 3 dynamic and static program.
- Geometric operating system

EQUILBRATRICE AUTOMATICA PROFESSIONALE PER RUOTE DA 12"- 24"

- Funzione di misurazione dinamica e statica.
- Funzione di auto-calibrazione
- Modalità misurazione ALU 1,2 e 3, dinamica e statica.
- Sistema di operazione geometrica.

KN233

Königstein



-  Localice los accesorios dentro de la máquina
-  Les accessoires se trouvent dans une tiroir située en bas à l'intérieur de la machine
-  Find the accessories inside the machine
-  Gli accessori sono situati nel cassetto in fondo alla macchina



ES: Escanee el código para más información.

FR: Scannez le code pour plus d'informations.

QR

EN: Scan the code for further information.

IT: Scansiona il codice per maggiori informazioni.





12" - 24"



800 mm



1.5 - 20"



0.25kw



(1 ~) 220V



0.90 x 0.75 x 1.16 m



150 kg

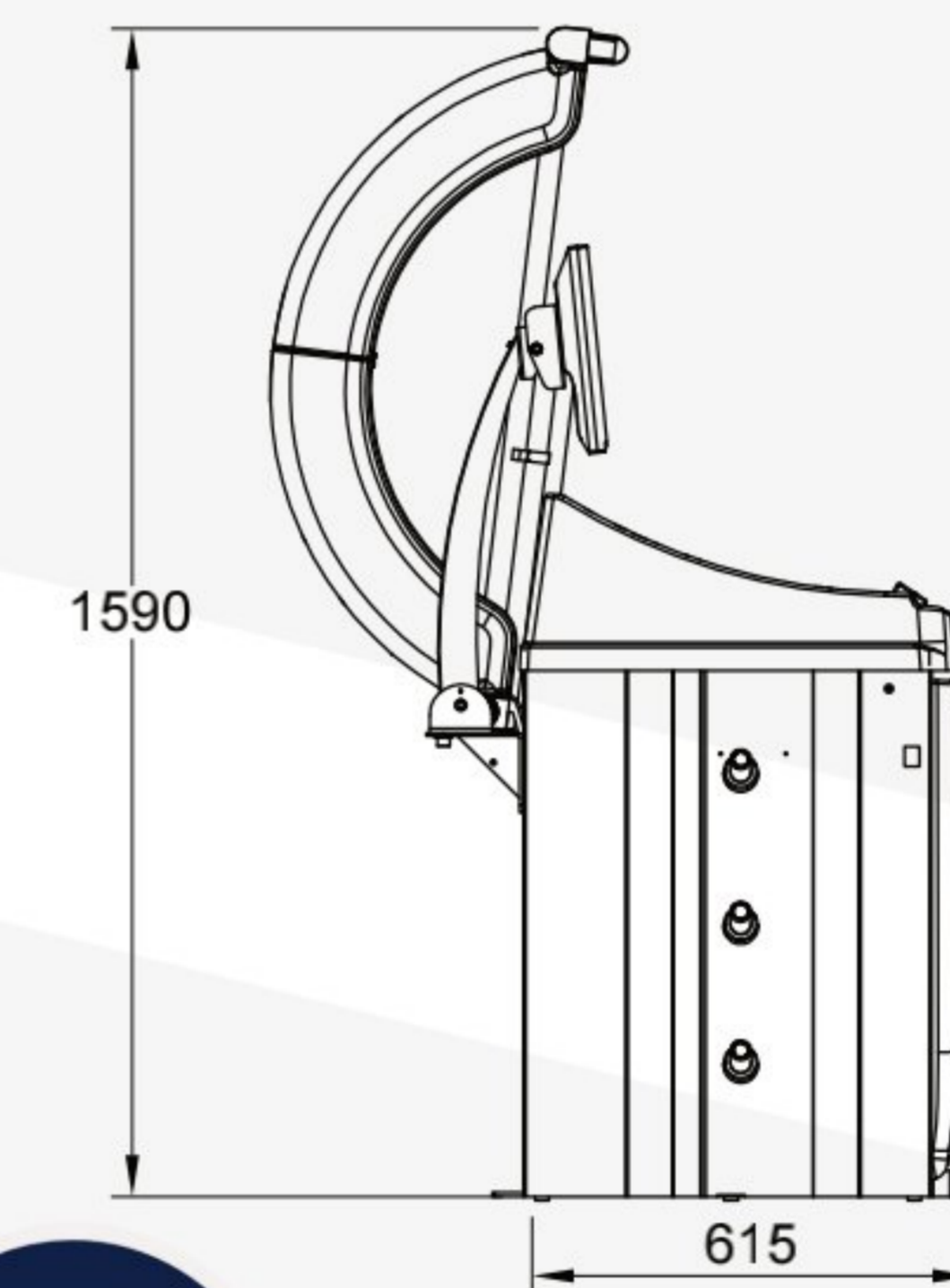
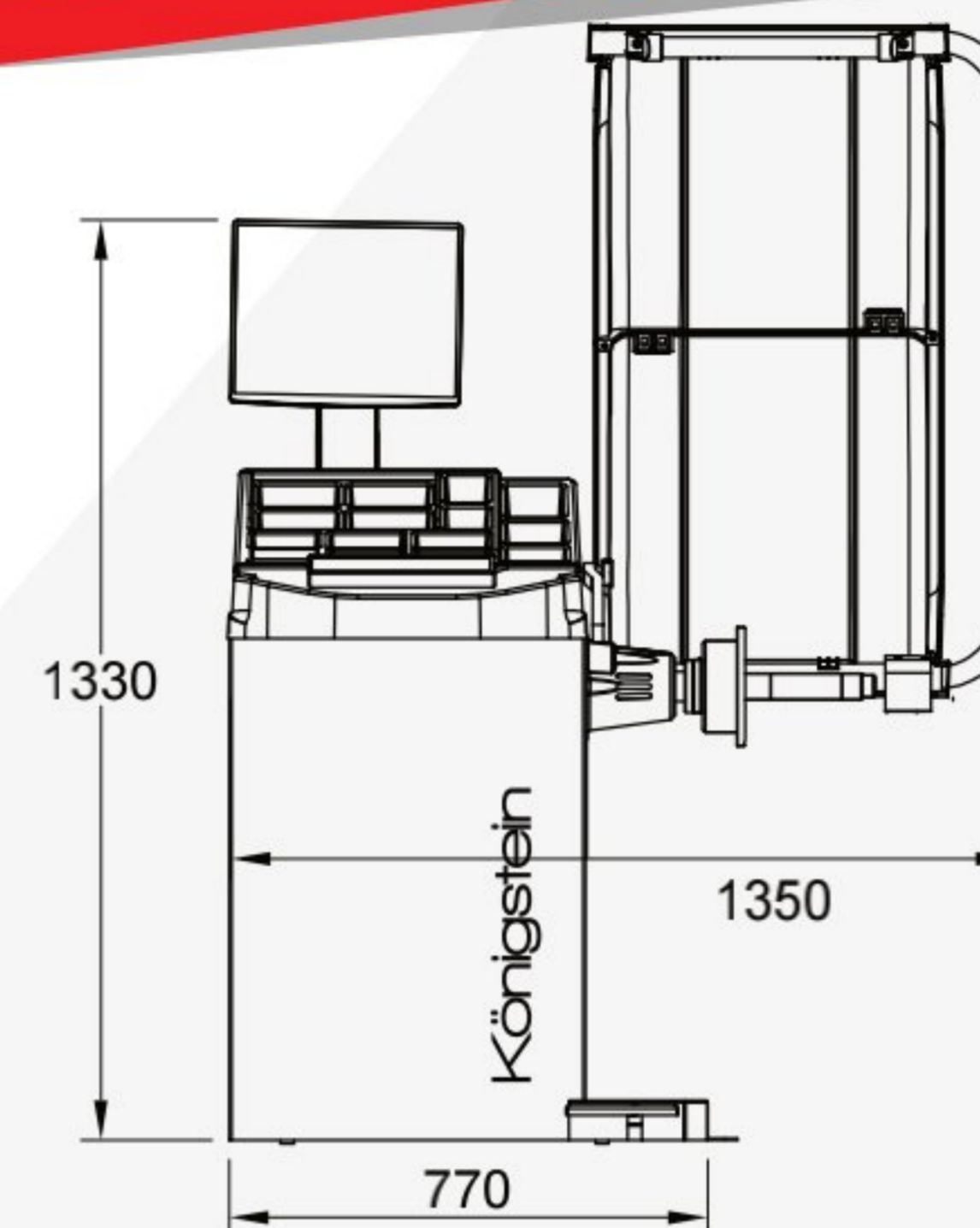

EQUILIBRADORA AUTOMÁTICA PROFESIONAL PARA RUEDAS DE 12"- 24"

- Función de medición dinámica y estática.
- Función de auto-calibración
- Modos de medición ALU 1,2 y 3 dinámico y estático.
- Sistema de operación geométrico

ÉQUILIBREUSE PROFESSIONNELLE AUTOMATIQUE POUR ROUES DE 12"- 24"

- Fonction de mesure dynamique et statique.
- Fonction d'auto-calibration
- Modes de mesure ALU 1,2 y 3 dynamique et statique.
- Système de géométrie

AUTOMATIC PROFESSIONAL WHEEL BALANCER 12"- 24" WHEELS.

- Dynamic and static measurement
- Self-calibration
- ALU 1,2 y 3 dynamic and static program.
- Geometric operating system

EQUILIBRATRICE AUTOMATICA PROFESSIONALE PER RUOTE DA 12"- 24"

- Funzione di misurazione dinamica e statica.
- Funzione di auto-calibrazione
- Modalità misurazione ALU 1,2 e 3, dinamica e statica.
- Sistema di operazione geometrica.

Alta precisión, Fácil de operar, Fácil de montar.

Haute précision, Facile à utiliser, Facile à assembler.

High accuracy, Easy to use, Easy to assemble.

Alta precisione, Facile da utilizzare, Facile da montare.

Königstein



Localice los accesorios dentro de la máquina

Les accessoires se trouvent dans une tiroir située en bas à l'intérieur de la machine

Find the accessories inside the machine

Gli accessori sono situati nel cassetto in fondo alla macchina

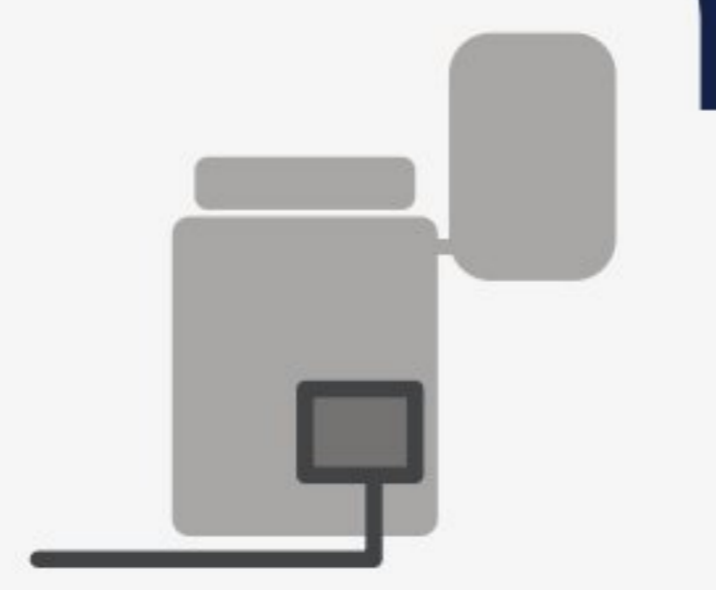

ES: Escanee el código para más información.

FR: Scannez le code pour plus d'informations.

EN: Scan the code for further information.

IT: Scansiona il codice per maggiori informazioni.





12" - 24"



800 mm

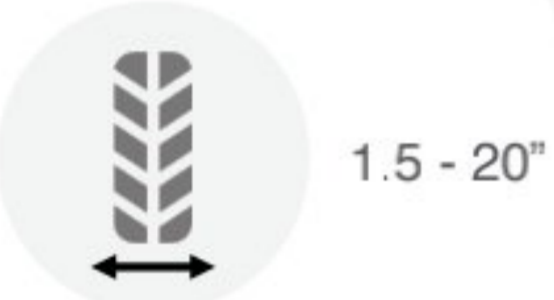

1.5 - 20"

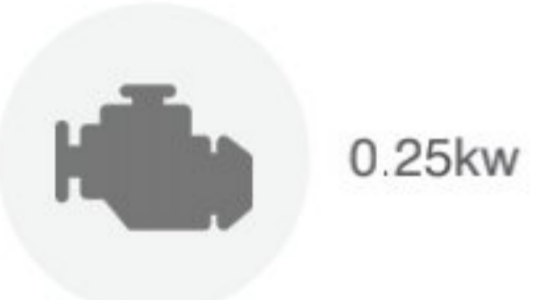

0.25kw

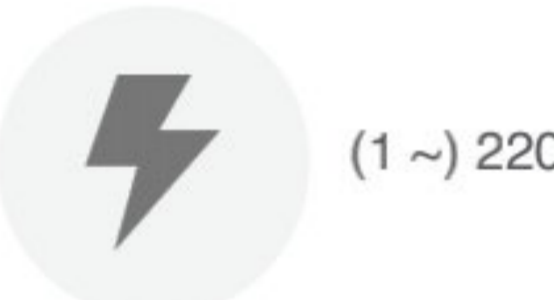

(1 ~) 220V



1.15 x 1 x 0.80 m



200 kg



- Alta precisión, Fácil de operar, Fácil de montar.
- Haute précision, Facile à utiliser, Facile à assembler.
- High accuracy, Easy to use, Easy to assemble.
- Alta precisione, Facile da utilizzare, Facile da montare.

KN260

Königstein



- Localice los accesorios dentro de la máquina
- Les accessoires se trouvent dans une tiroir située en bas à l'intérieur de la machine
- Find the accessories inside the machine
- Gli accessori sono situati nel cassetto in fondo alla macchina

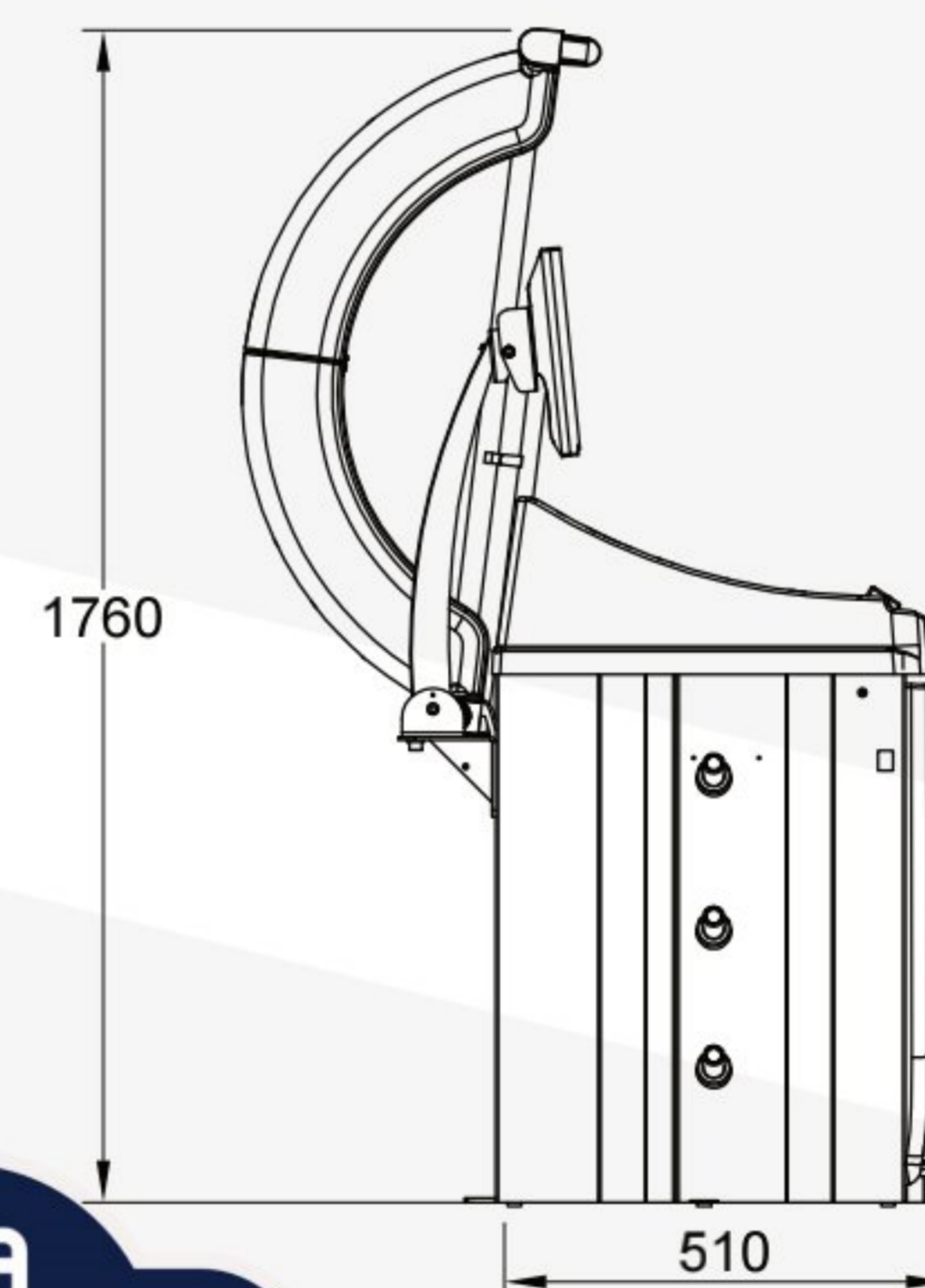
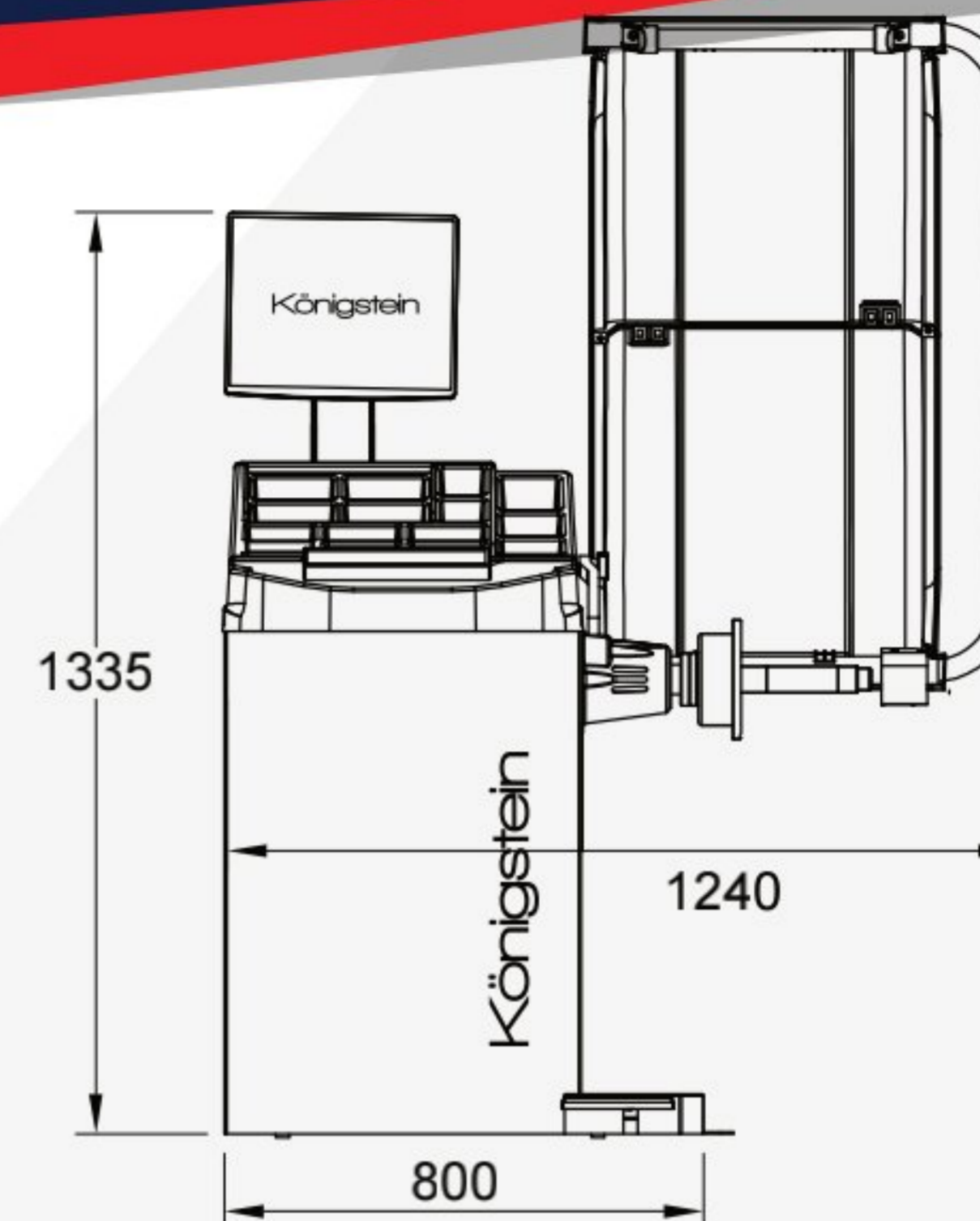
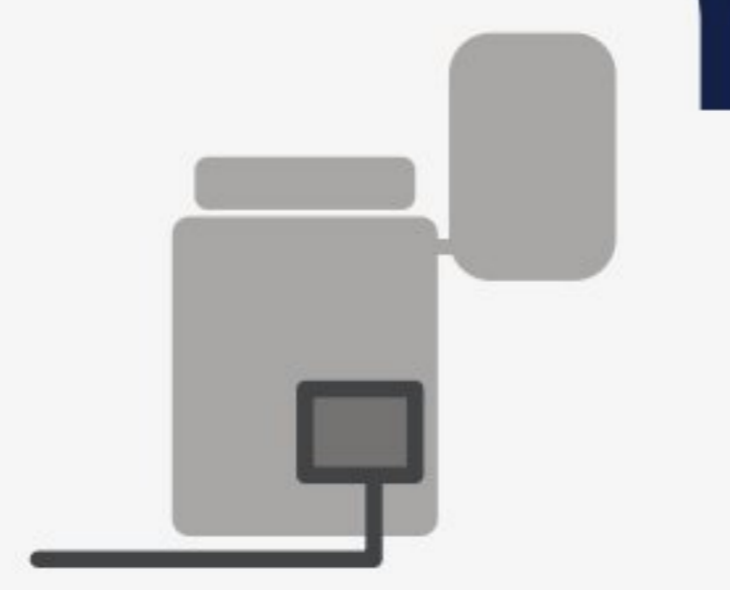

EQUILBRADORA DIGITAL CON PANTALLA DE VIDEO

- Equilibradora digital con pantalla de video.
- Software intuitivo que facilita el trabajo
- Laser que indica la posición donde se ha de colocar la contrapesa en llantas de aluminio.

ÉQUILIBREUSE NUMÉRIQUE AVEC ÉCRAN VIDÉO

- Équilibruse numérique avec écran.
- Logiciel intuitif qui facilite le travail
- Laser qui indique la position où le contrepoids doit être placé sur les jantes en aluminium.

AUTOMATIC WHEEL BALANCER WITH VIDEO SCREEN

- Digital balancer with video screen.
- Intuitive software easy to use
- Laser system for weight placement.

EQUILBRATRICE DIGITALE CON SCHERMO VIDEO

- Equilibratrice digitale con schermo video.
- Software intuitivo che facilita il lavoro.
- Laser che indica la posizione dove bisogna collocare il contrappeso su cerchi di alluminio.



ES: Escanee el código para más información.

FR: Scannez le code pour plus d'informations.

EN: Scan the code for further information.

IT: Scansiona il codice per maggiori informazioni.





2.5 kg



4660 mm



2.2 kw



(3 ~) 380V



1.15 x 1 x 0.80 m



1300 kg

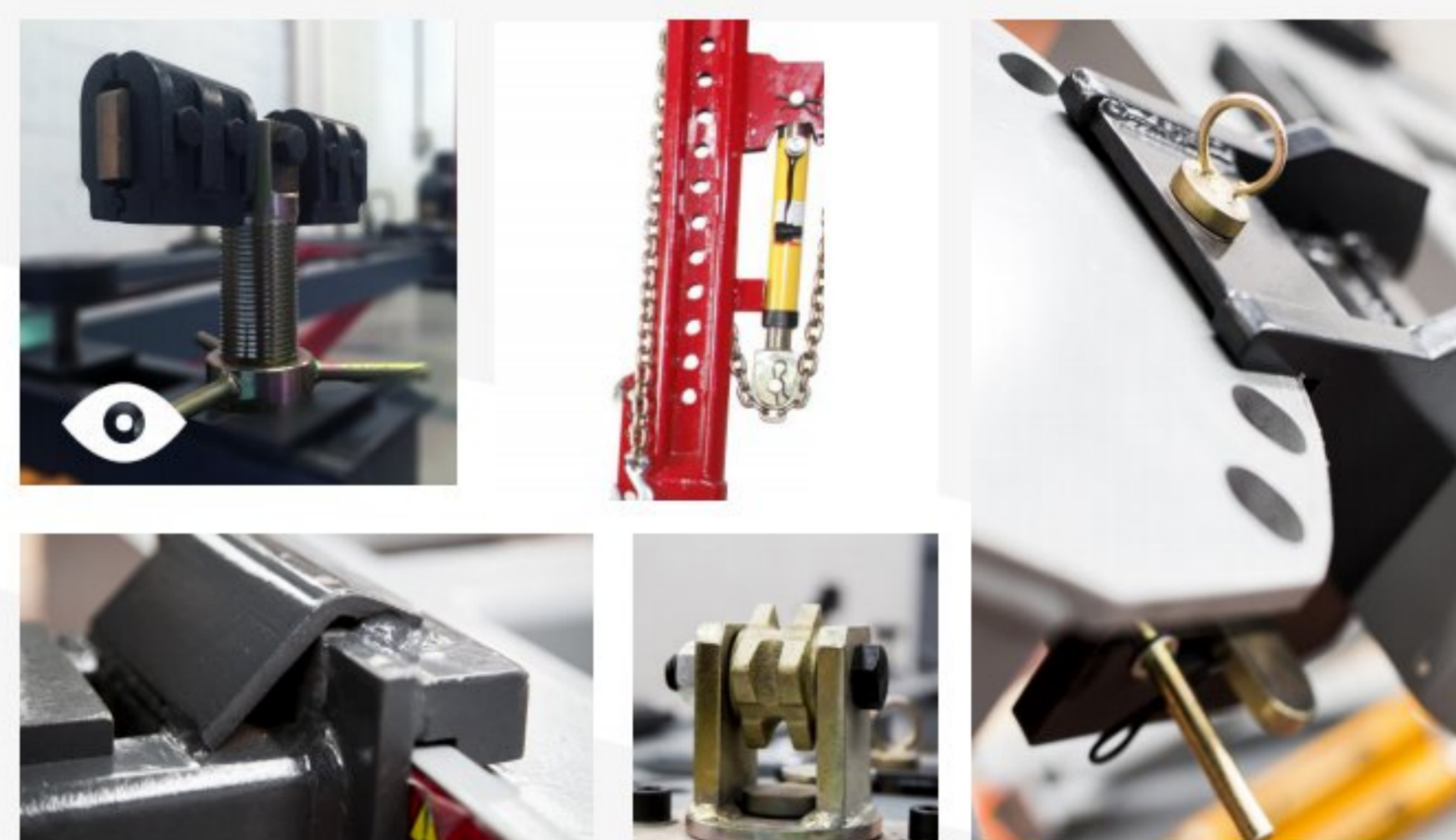
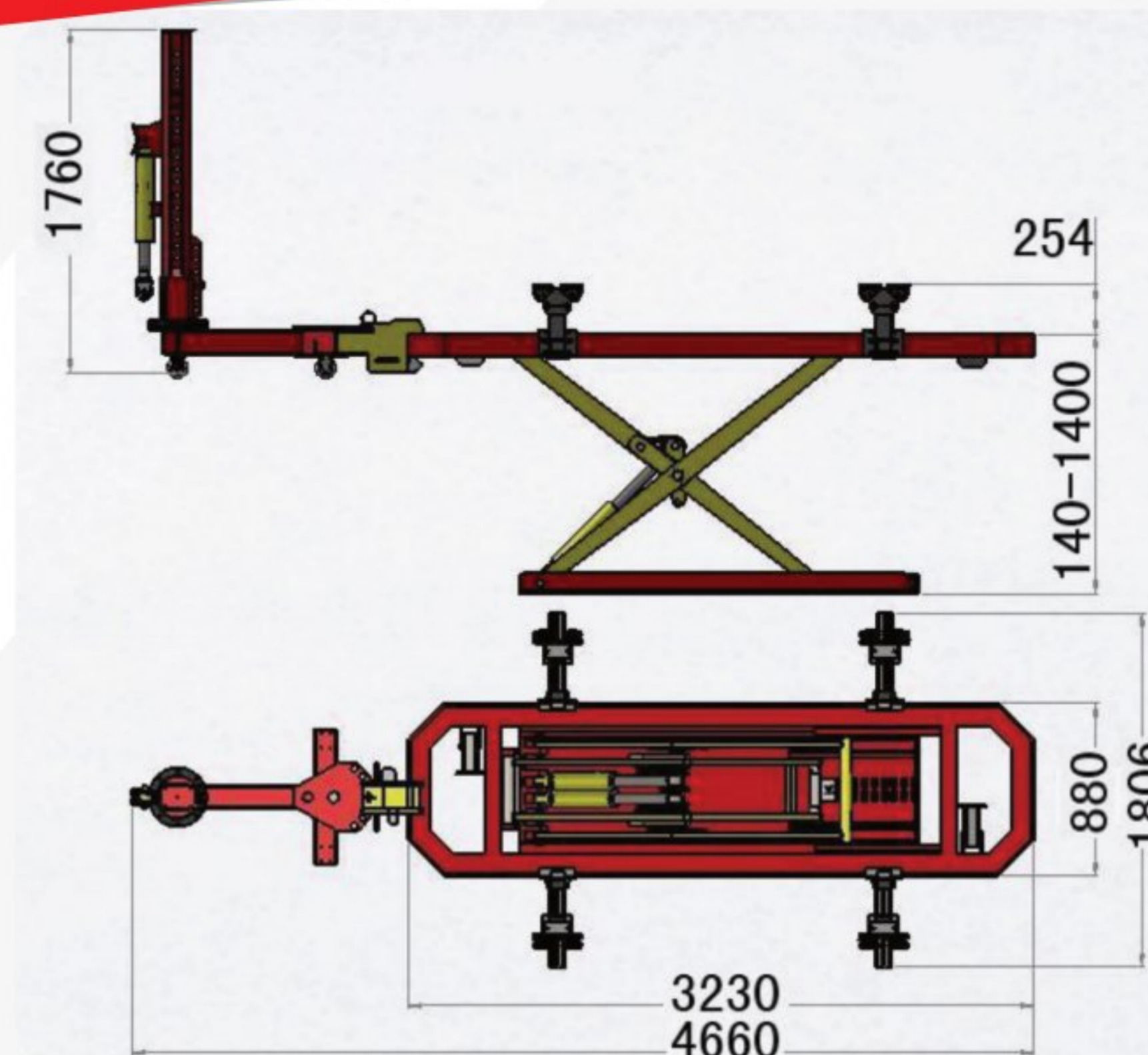
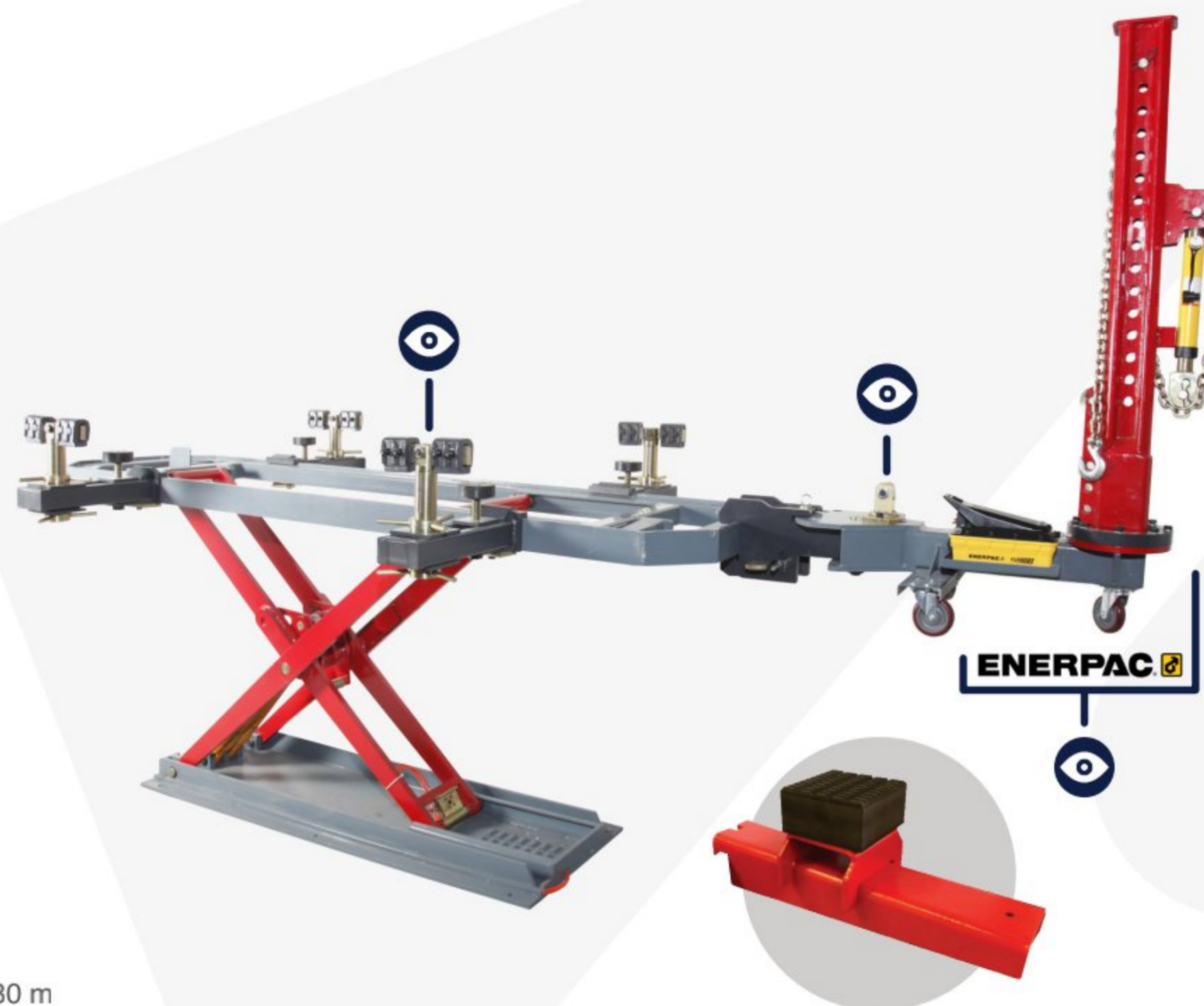

QR

ES: Escanee el código para más información.

FR: Scannez le code pour plus d'informations.

EN: Scan the code for further information.

IT: Scansiona il codice per maggiori informazioni.

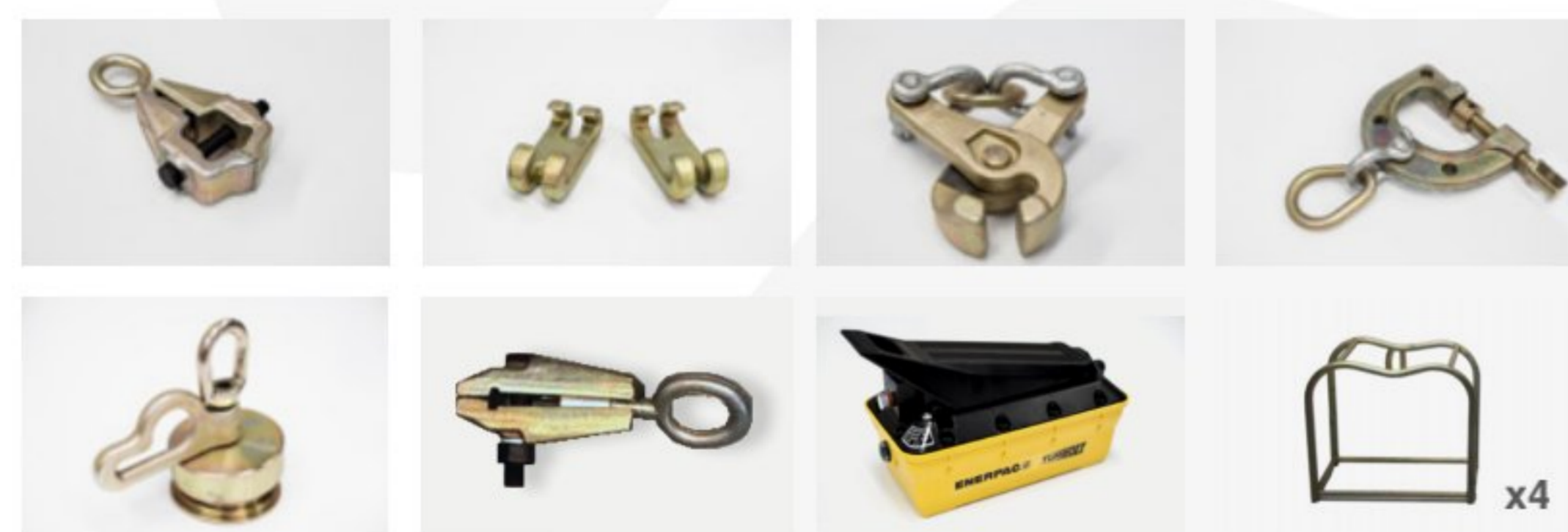

KN720

Königstein

- Opcional
- Optionel
- Option
- Opzione

- Incluido
- Inclus
- Included
- Inclusi

MINIBANCO DE TIRO RÁPIDO

- Elevador integrado con capacidad de elevación de 2500kg
- Elevación 1.4 metros, lo que facilita el trabajo en cualquier tipo de vehículo incluyendo 4x4 y furgonetas
- Tiro vertical de 1.76 metros de altura y 10T de potencia, aplicables en los 360° de la bancada.

MINI BANC DE TIRAGERAPIDE

- Banc élévateur intégré capacité de 2500 Kg
- Élévation de 1.4M, pour faciliter le travail sur n'importe quel type de véhicule y compris véhicules 4x4 et fourgonnettes.
- Bras tirant de 1.76M de hauteur et 10T de capacité, utilisable sur les 360° du banc.

QUICK PULL MINIBENCH

- 2500kg built-in lift.
- 1.4 m lift for different car types, including 4x4 and vans.
- 1.76 m vertical pull. 10T power, on 360° bench.

MINI BANCO DI TIRO RAPIDO

- Sollevatore integrato con capacità di sollevamento di 2500kg.
- Sollevamento di 1.4 metri, il quale facilita il lavoro per qualunque tipo di veicolo, inclusi i 4x4 e i furgoni.
- Tiro verticale di 1.76 metri di altezza e 10T di potenza, applicabili a 360° del banco.



12" - 25"



(1 ~) 220V



Pack 1:
1090*860*740mm

Pack 2:
2930*240*410mm

Pack 3:
630*630*1220mm

Pack 4:
2910*380*330mm



280 kg

KN7070

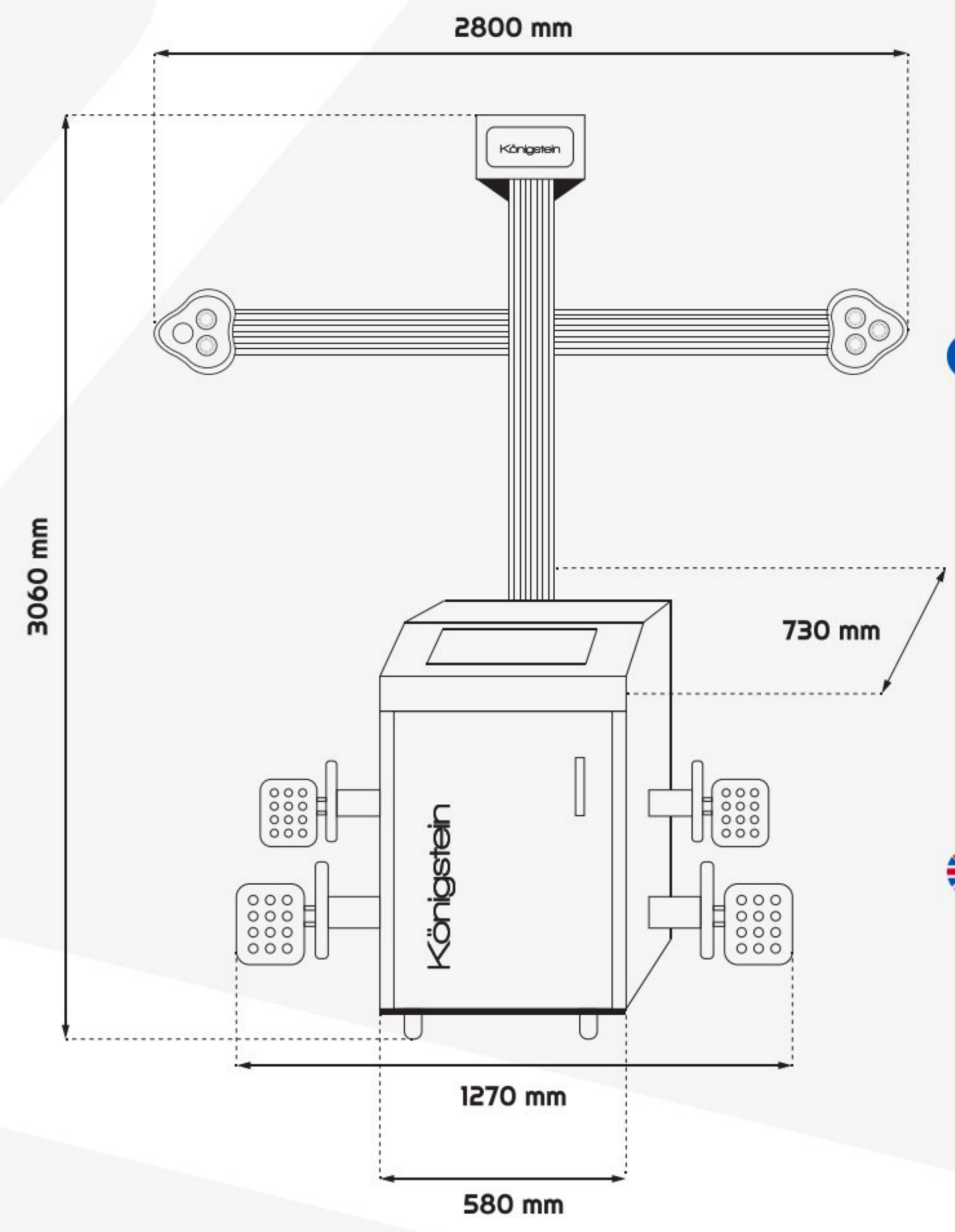

ALINEADOR 3D AUTOMÁTICO

- Equipo de alineación 3D con cámaras ajustable en altura de manera automatizada
- Software de fácil utilización para una rápida gestión del proceso de alineación
- Con base de Datos oficial AUTODATA con más de 17000 vehículos actualizable periódicamente

APPAREIL DE GÉOMÉTRIE 3D AUTOMATIQUE

- Équipement d'alignement 3D avec caméras à hauteur réglable par dispositif automatisé
- Logiciel intuitif et ergonomique pour une gestion rapide du processus d'alignement
- Base de données officielle AUTODATA avec plus de 17 000 véhicules référencés actualisable régulièrement

3D AUTOMATIC ALIGNMENT

- 3D aligning equip. Automatic height adjustment camera included
- Alignment process with easy software use
- AUTODATA data base. Over 17000 vehicles continued updating

ASSETTO RUOTE 3D AUTOMATICO

- Strumenti di allineamento 3D con videocamera regolabile in altezza in modo automatizzato.
- Software di facile utilizzo per una rapida gestione del processo di assetto delle ruote.
- Database ufficiale AUTODATA con più di 17000 veicoli aggiornata periodicamente.



ES: Escanee el código para más información.

FR: Scannez le code pour plus d'informations.

EN: Scan the code for further information.

IT: Scansiona il codice per maggiori informazioni.



NOTA: Las imágenes mostradas tienen el propósito de representar el producto solamente y pueden variar dependiendo del modelo y stock

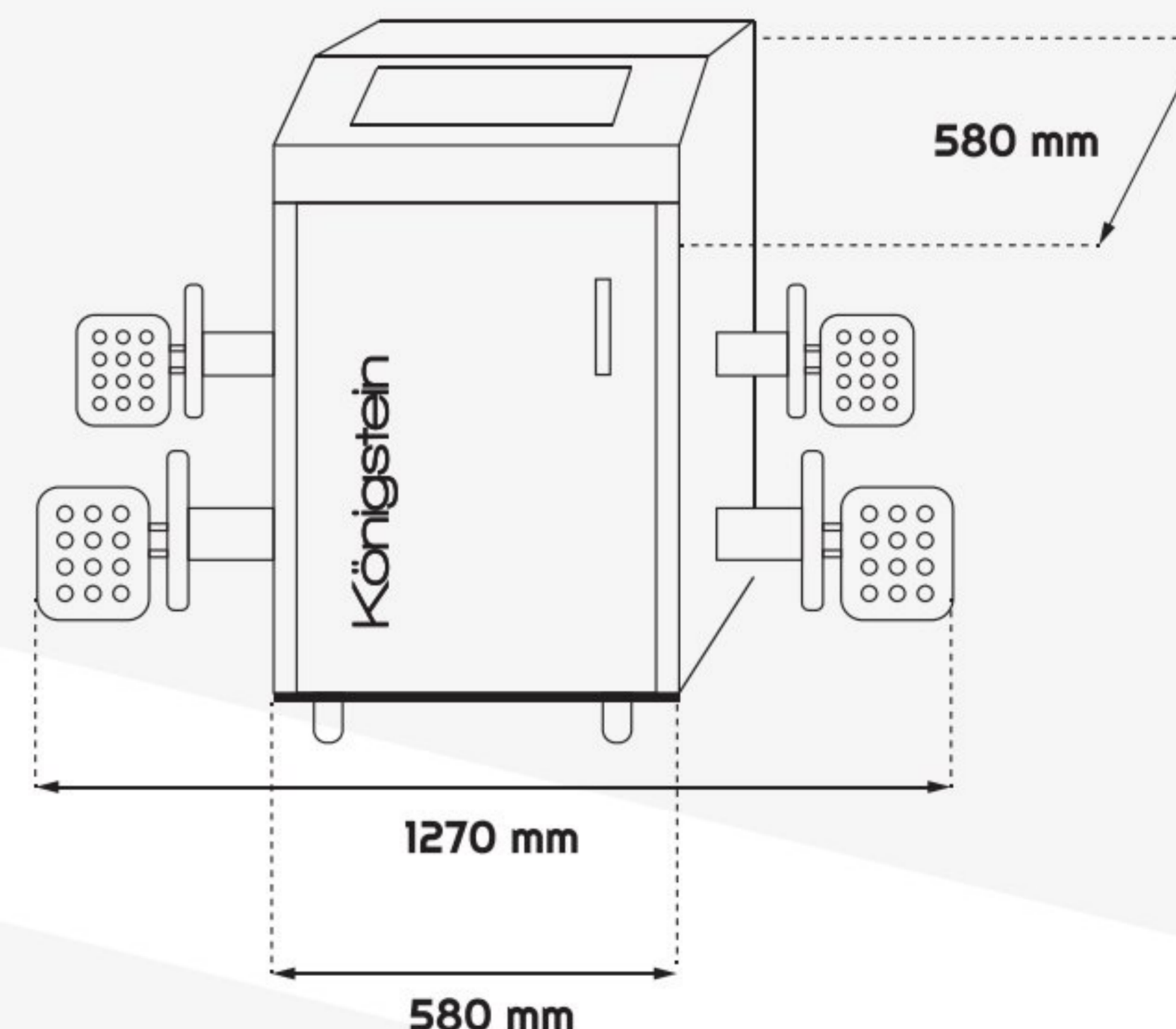
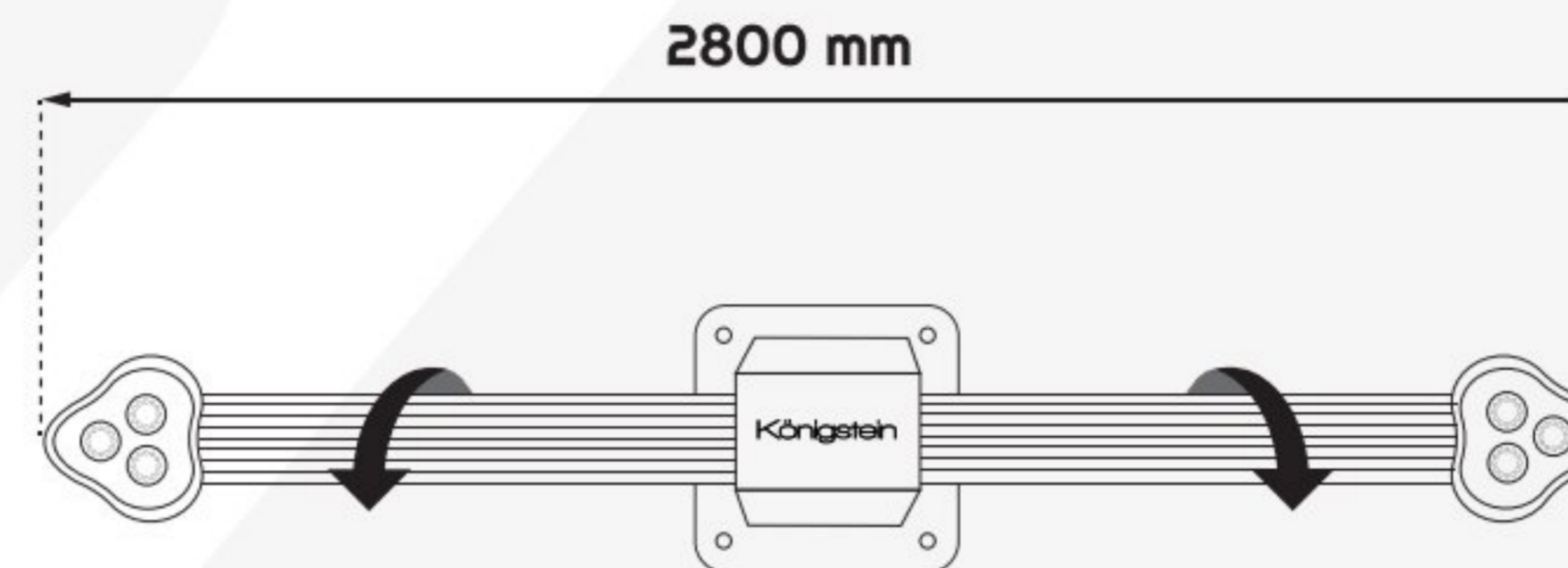

ALINEADOR 3D DE PARED CON MANDO A DISTANCIA

- Equipo de alineación 3D con cámaras ajustable en ángulo a través de mando a distancia
- Software de fácil utilización para una rápida gestión del proceso de alineación
- Con base de Datos oficial AUTODATA con más de 17000 vehículos actualizable periódicamente

APPAREIL 3D MURAL AVEC CONTRÔLE À DISTANCE

- Équipement d'alignement 3D avec caméras à angle réglable par télécommande
- Logiciel intuitif et ergonomique pour une gestion rapide du processus d'alignement
- Base de données officielle AUTODATA avec plus de 17 000 véhicules référencés actualisable régulièrement

WALL 3D ALIGNMENT REMOTE CONTROL

- 3D alignment kit. Adjustable angle cameras with remote control.
- Alignment process with easy software use
- AUTODATA data base. Over 17000 vehicles continued updating

ASSETTO RUOTE 3D DA PARTE CON COMANDO A DISTANZA

- Strumenti di allineamento 3D con videocamera regolabile movimento da CONTROLLO REMOTO
- Software di facile utilizzo per una rapida gestione del processo di assetto delle ruote.
- Database ufficiale AUTODATA con più di 17000 veicoli aggiornata periodicamente.



12"- 25"



(1 ~) 220V

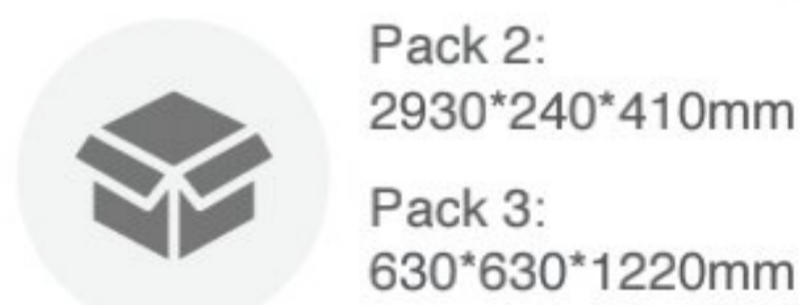

Pack 1:
1090*860*740mm



Pack 2:
2930*240*410mm



Pack 3:
630*630*1220mm



Pack 4:
220*420*360mm

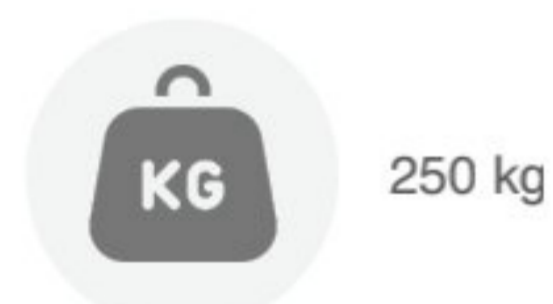

250 kg



KN7050DA

Königstein



ES: Escanee el código para más información.

FR: Scannez le code pour plus d'informations.

EN: Scan the code for further information.

IT: Scansiona il codice per maggiori informazioni.



NOTA: Las imágenes mostradas tienen el propósito de representar el producto solamente y pueden variar dependiendo del modelo y stock

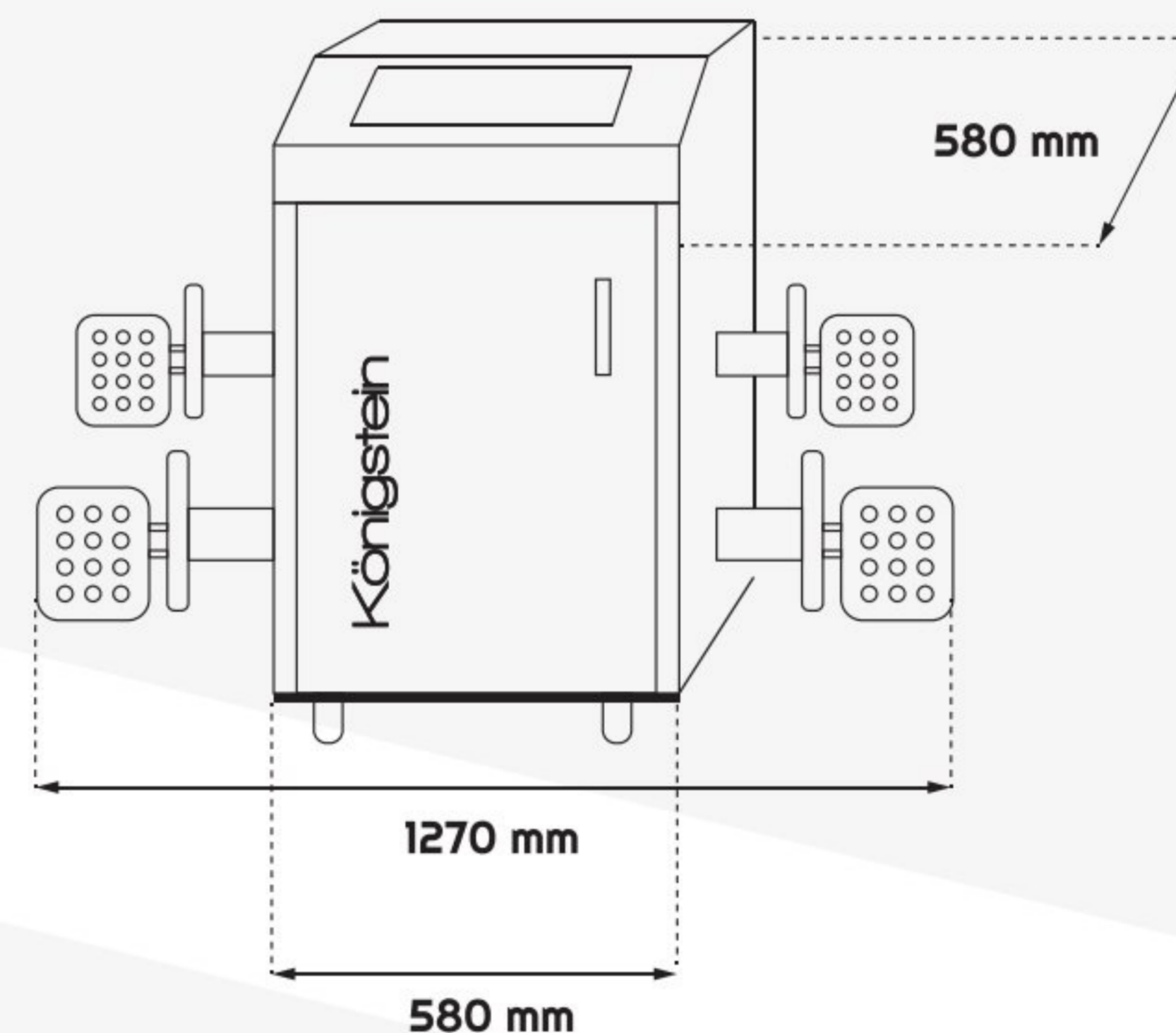
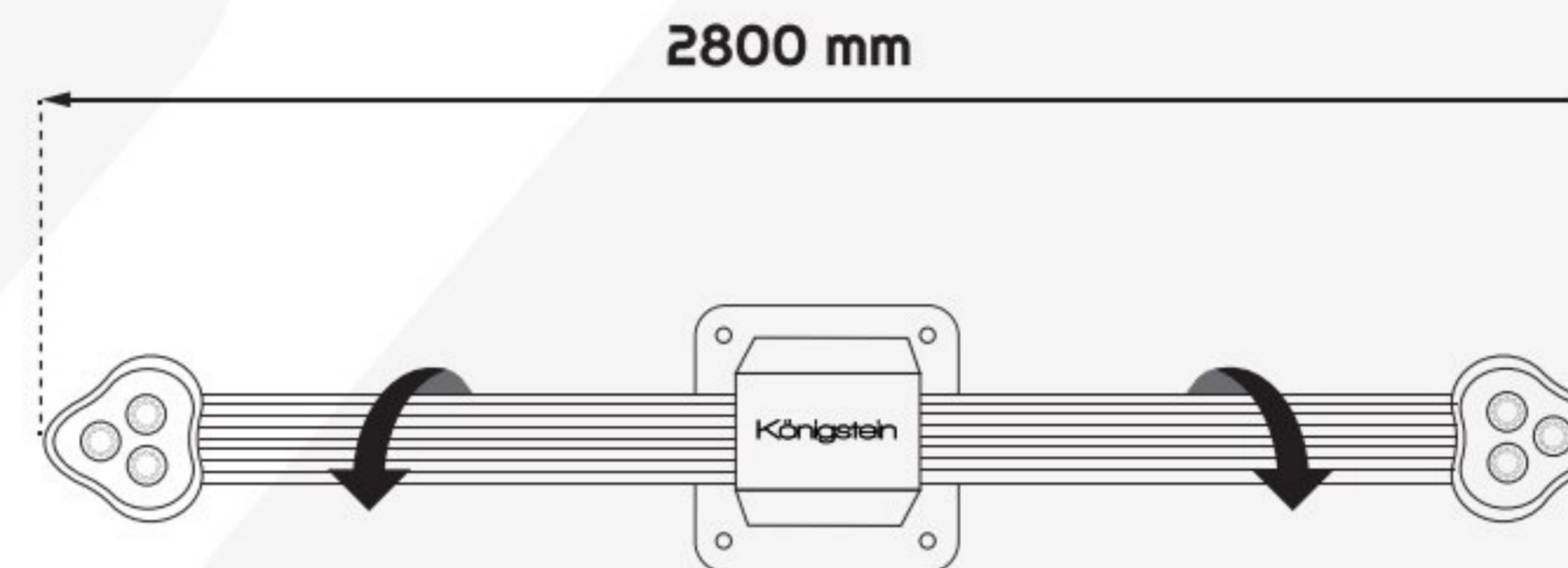

12" - 25"



(1 ~) 220V



Pack 1:
1090*860*740mm

Pack 2:
2930*240*410mm

Pack 3:
630*630*1220mm

Pack 4:
220*420*360mm



250 kg



KN7050DF

Königstein



ES: Escanee el código para más información.

FR: Scannez le code pour plus d'informations.

EN: Scan the code for further information.

IT: Scansiona il codice per maggiori informazioni.



ALINEADOR 3D DE PARED CON CÁMARAS FIJAS

- Equipo de alineación 3D con cámaras fijas.
- Software de fácil utilización para una rápida gestión del proceso de alineación
- Con base de Datos oficial AUTODATA con más de 17000 vehículos actualizable periódicamente

APPAREIL 3D FIXE CÁMERAS FIXES

- Équipement d'alignement 3D avec caméras fixes
- Logiciel intuitif et ergonomique pour une gestion rapide du processus d'alignement
- Base de données officielle AUTODATA avec plus de 17 000 véhicules référencés actualisable régulièrement

3D FIXED ALIGNMENT WITH FIXED CAMERAS

- 3D aligning equipment with fixed cameras.
- Alignment process with easy software use
- AUTODATA data base. Over 17000 vehicles continued updating

ASSETTO RUOTE 3D FISSO VIDEOCAMERE FISSE

- Strumenti di allineamento 3D con videocamere fisse.
- Software di facile utilizzo per una rapida gestione del processo di assetto delle ruote.
- Database ufficiale AUTODATA con più di 17000 veicoli aggiornata periodicamente.

Königstein

3T

-  1230mm
-  118 mm
-  3000 kg
-  3 kw
-  (3 ~) 400/50V / Hz
- 
-  580 kg



**BRAZOS AUTOMÁTICOS INCLUIDOS
CENTRALITA APEX OPCIONAL**

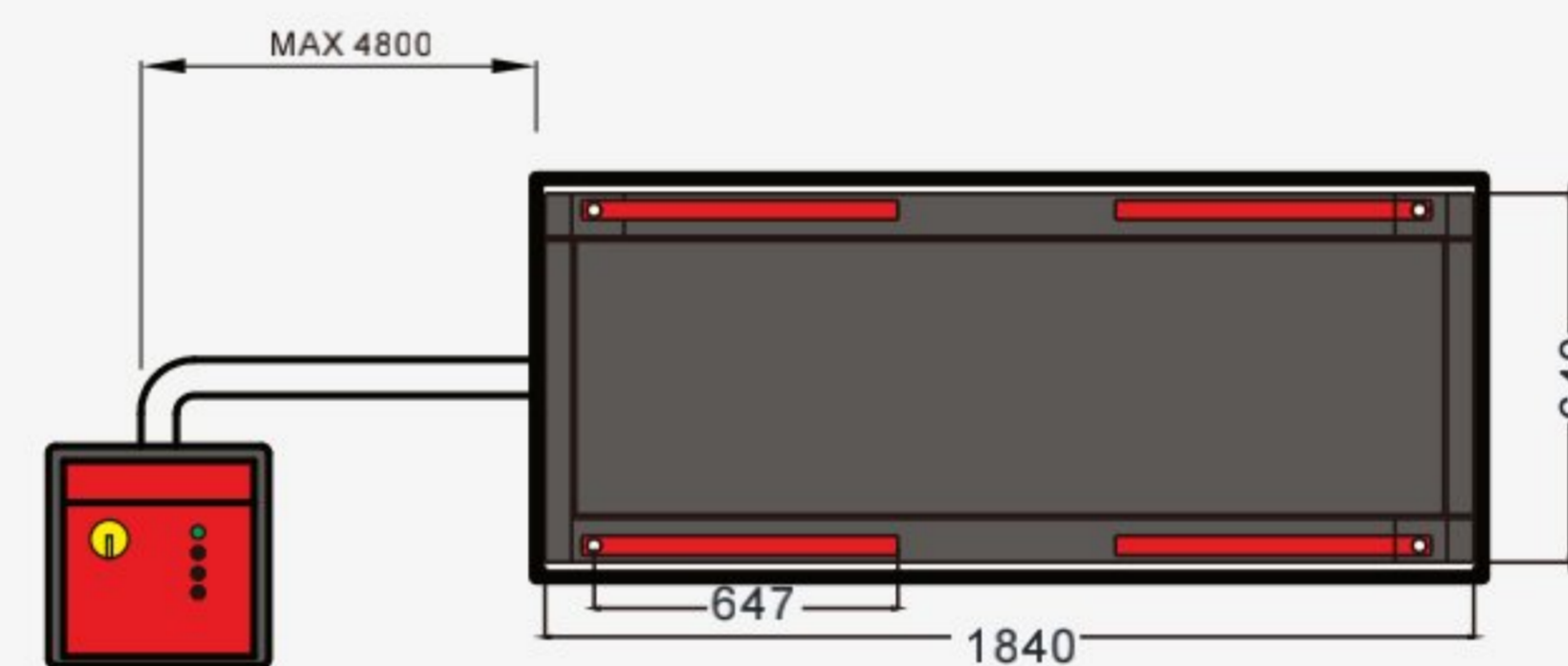
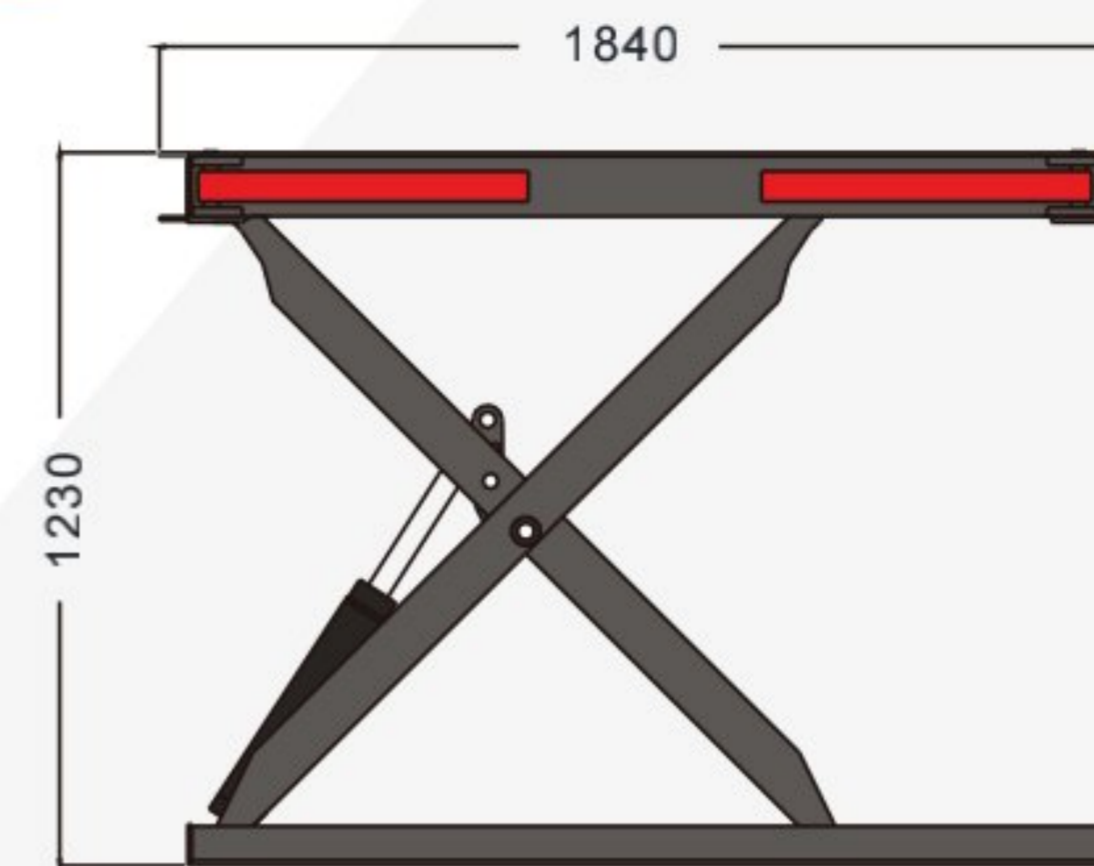

ELEVADOR DE TIJERA PARA CABINA DE PINTURA Y ZONA DE PREPARACIÓN

- Panel de control de 24V, Dispositivo de Seguridad Neumático-Mecánico
- Estructura de aleación de acero, con límite elástico de 355 Mpa
- Ideal para empotrar en la rejilla de la cabina de pintura del taller y/o en las zonas de preparación.

PONT CISEAUX POUR CABINE DE PEINTURE ET ZONE DE PRÉPARATION

- Panneau de commande 24V, dispositif de sécurité pneumo-mécanique
- Structure alliée en acier, limite d'élasticité de 355 Mpa.
- Idéal pour être encastré dans les caillebotis de la cabine de peinture et zones de préparation.

SPRAY BOOTH SCISSOR LIFT

- 24V Dead Man control, Pneumatic-Mechanical Safety device
- Alloy-Steel structure, yield strength 355Mpa
- Suits recessed instillation in bodyshop spry booth grid and preparing areas.





SOLLEVATORE A FORBICE CABINA DI VERNICIATURA E/O DELLE AREE DI PREPARAZIONE

- Pannello di controllo 24V, dispositivo di sicurezza pneumo-meccanico
- Struttura in acciaio con resistenza 355 Mpa.
- Ideale per incassare nel grigliato della cabina di verniciatura e/o delle aree di preparazione.

KN3630CP

Königstein



-  Cilindros mas resistentes, retenes de calidad y válvula paracaídas.
-  Cylindres 60% d'épaisseur en plus, plus résistants, joints de qualité et valve parachute
-  Stronger cylinders, High-quality oil rings and parachute valve.
-  Cilindri 60% più spessi, più resistenti, guarnizioni di qualità e valvola a paracadute.



ES: Escanee el código para más información.

EN: Scan the code for further information.

FR: Scannez le code pour plus d'informations.

IT: Scansiona il codice per maggiori informazioni.



Königstein

1.5T



1800mm

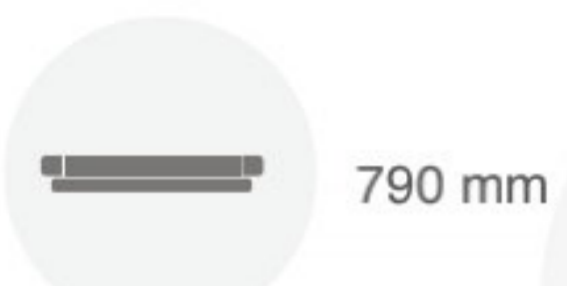

790 mm



1500 kg



1.8 kw

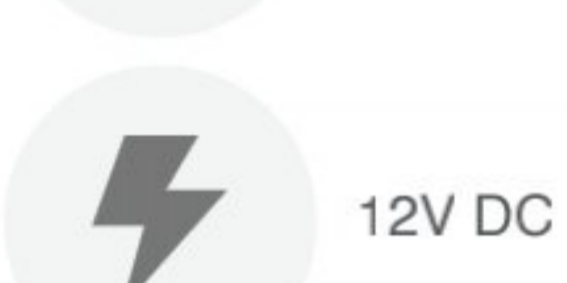

12V DC



1.6 0.88 x 0.90 m



375 kg





 **Incluye**
Correas
Tacos de goma
Llaves estandar

 **Inclus**
Sangles
Tampons caoutchouc
Clés standards

 **Include**
Straps
Rubber pads
Standard keys

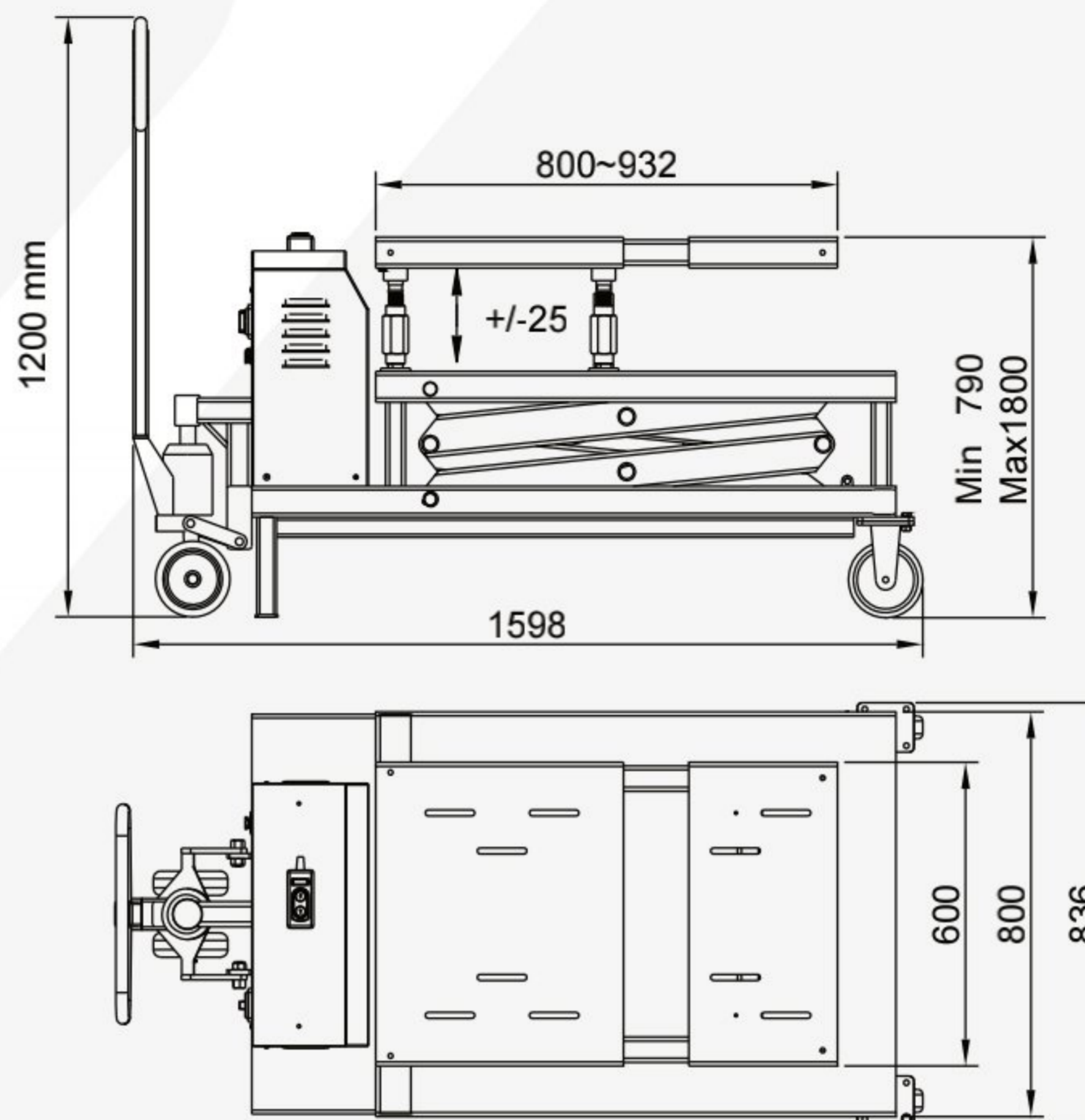
 **Inclusi**
Cinghie
Tasselli in gomma
Chiavi standard



 Mando a distancia con cable de 3 metros que facilita el uso de la máquina desde cualquier punto alrededor de la misma.

 La commande à distance dotée d'un câble de 3 mètres, rend l'appareil facile à utiliser depuis n'importe quel point autour de la machine.

 3 meters cable control for easy operating in any direction.

 Comando a distanza con cavo di 3 metri che facilita l'uso della macchina da qualunque punto intorno alla stessa.

 **MESA ELEVADORA IDEAL PARA MOTOR, TRANSMISION, CAJAS DE CAMBIO Y BATERÍAS**

- Elevador para descargar y trasladar motores y transmisiones así como también baterías de vehículos eléctricos. También puede ser utilizado como mesa de trabajo para acceder a reparaciones en lugares altos de difícil acceso.

- La máquina es operada con una batería de 12V DC para mayor seguridad, elevación suave y amistosa con el medio ambiente. También disponible version AC.

 **TABLE ÉLÉVATRICE**

- Élévateur pour le déchargement et le déplacement des moteurs et des transmissions ainsi que des batteries de véhicules électriques. Il peut également être utilisé comme table de travail lors de réparations dans des endroits élevés et difficiles d'accès.

- La machine fonctionne avec une batterie de 12V DC pour une plus grande sécurité, une levée souple et le respect de l'environnement. Également disponible en version AC.

 **LIFTING TABLE**

- Lift used for moving and unloading motors, transmissions and electric vehicle batteries.

- 12V DC battery operated for safety and environment friendly. AC version available.

 **SOLLEVATORE PER TRASMISSIONI E MOTORI**

- Sollevatore per scaricare e spostare motori così come le batterie di veicoli elettrici. Può essere anche utilizzato come tavolo da lavoro per compiere delle riparazioni in posti alti e di difficile accesso.

KN3009

Königstein

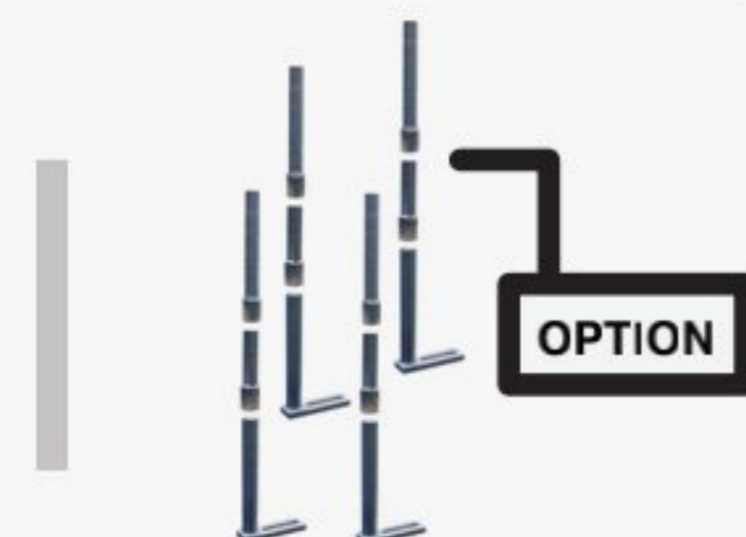
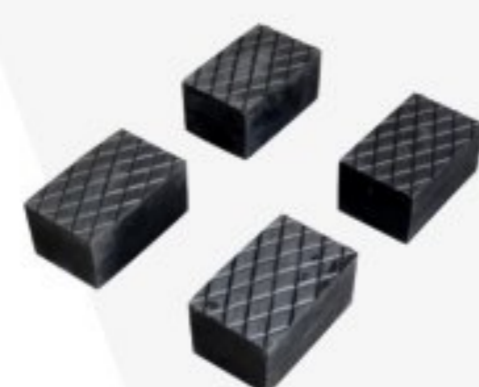

ES: Escanee el código para más información.

FR: Scannez le code pour plus d'informations.

EN: Scan the code for further information.







IT: Scansiona il codice per maggiori informazioni.



Königstein

NOTA: Las imágenes mostradas tienen el propósito de representar el producto solamente y pueden variar dependiendo del modelo y stock





2.5T

-  1050 mm
-  115 mm
-  2500 kg
-  2715 mm
-  (1~) 220V
-  ...
-  322 kg

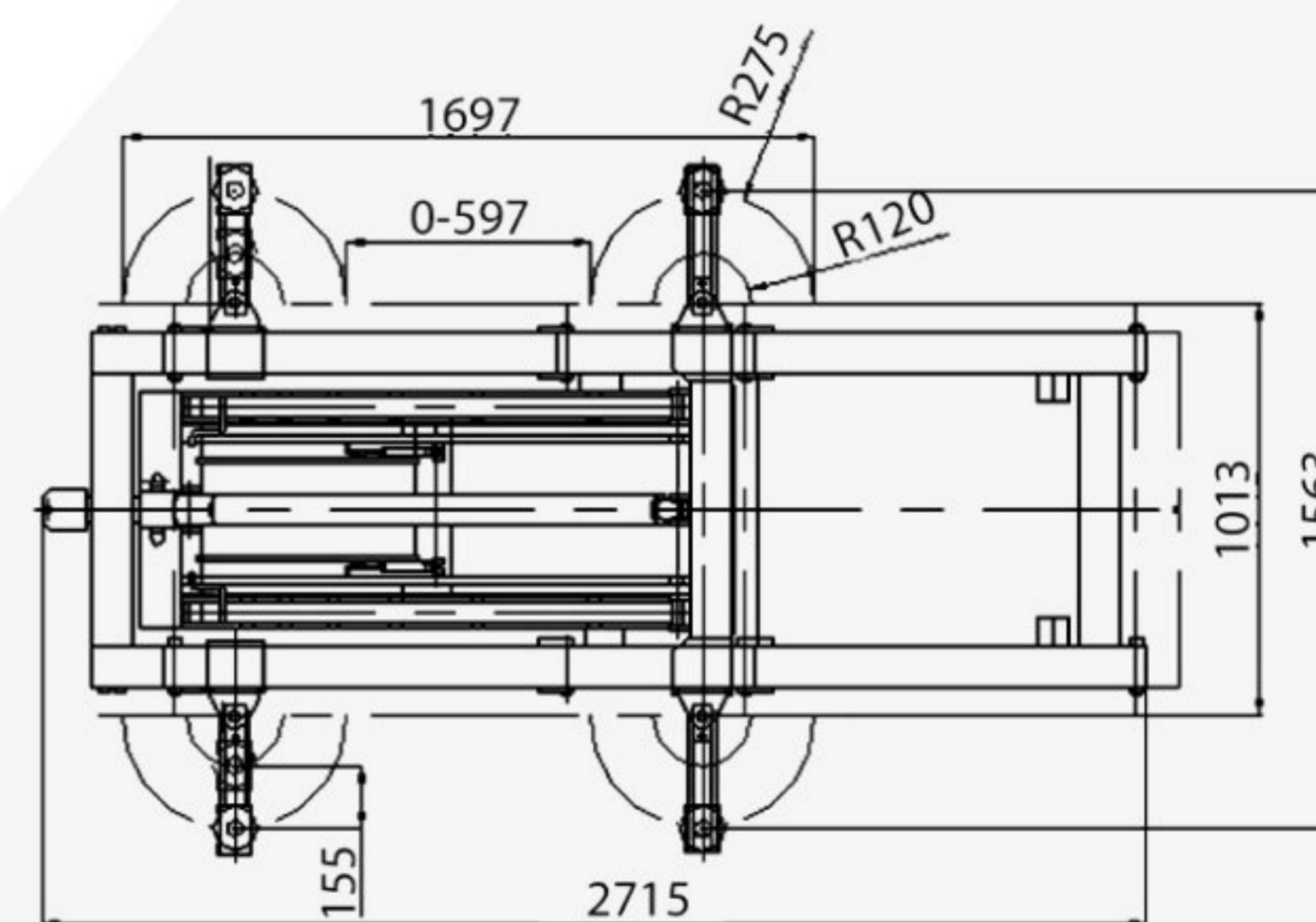
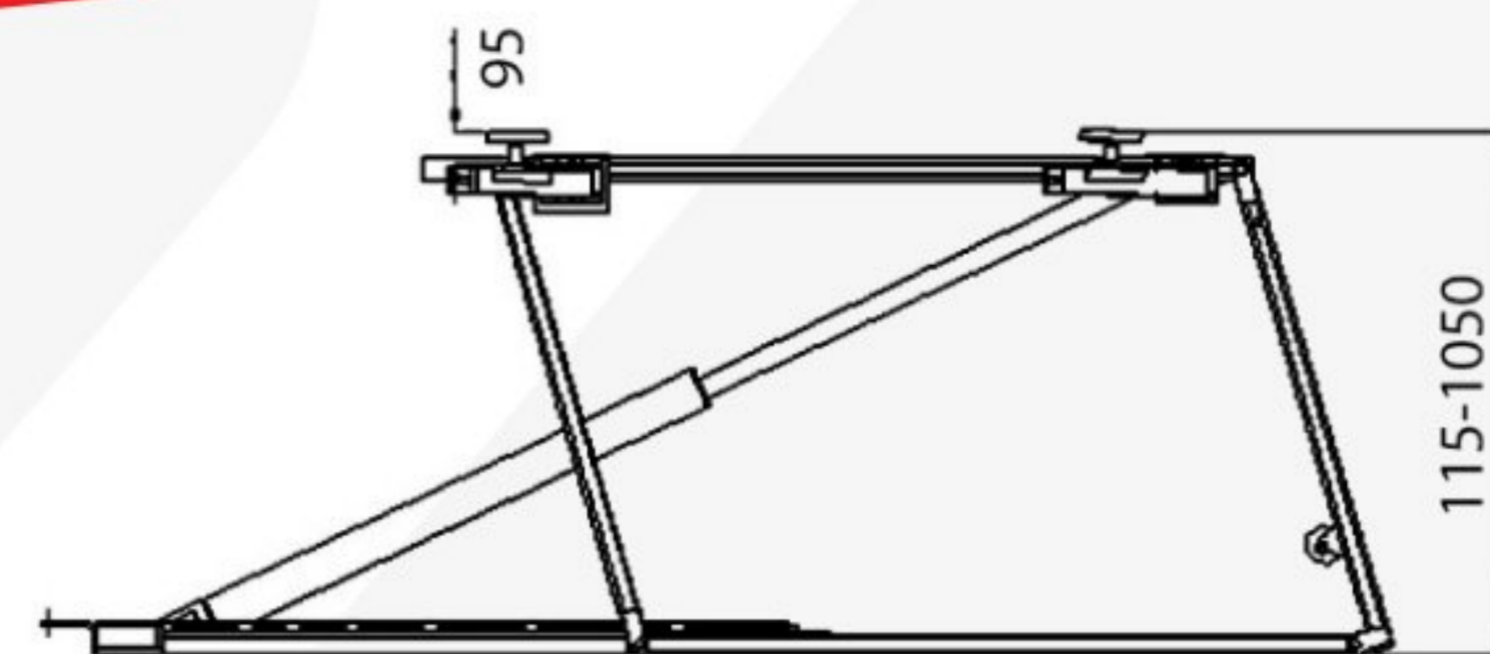

ACCESORIOS OPCIONALES | ACCESSOIRES
OPTIONNELS | OPTIONAL | ACCESSORI OPZIONALI



-  Brazos ajustables en distintas posiciones
-  Bras réglables dans différentes positions
-  Bracci regolabili in diverse posizioni
-  Multi positioning arms

 **ELEVADOR DE CHAPISTA**

- Doble sistema bloqueo automático de seguridad con liberación neumática.
- Brazos de sujeción ajustables.
- Cilindro hidráulico.
- Se puede transportar para su uso en distintas instalaciones.

 **ELÉVATEUR À CISEAUX DE MI-HAUTEUR MOBILE ET TRANSPORTABLE**

- Double système de verrouillage de sécurité automatique avec libération pneumatique.
- Bras de serrage ajustables.
- Cylindre hydraulique.
- Peut être facilement transporté pour être utilisé dans différentes installations.

 **MOBILE MEDIUM HEIGHT SCISSOR LIFT**

- Double automatic safety locking system with pneumatic release.
- Adjustable holding arms
- Hydraulic cylinder
- Easy to transport

 **SOLLEVATORE A FORBICE DI MEDIA ALTEZZA MOBILE E PORTATILE**

- Doppio sistema di blocco automatico di sicurezza con liberazione pneumatica.
- Bracci di fissaggio regolabili.
- Si può trasportare per essere utilizzato in diverse installazioni.









ES: Escanee el código para más información.

FR: Scannez le code pour plus d'informations.

EN: Scan the code for further information.

IT: Scansiona il codice per maggiori informazioni.



-  1100 mm
-  115 mm
-  600 kg
-  2572 mm
-  (1~) 220V
-  ...
-  322 kg

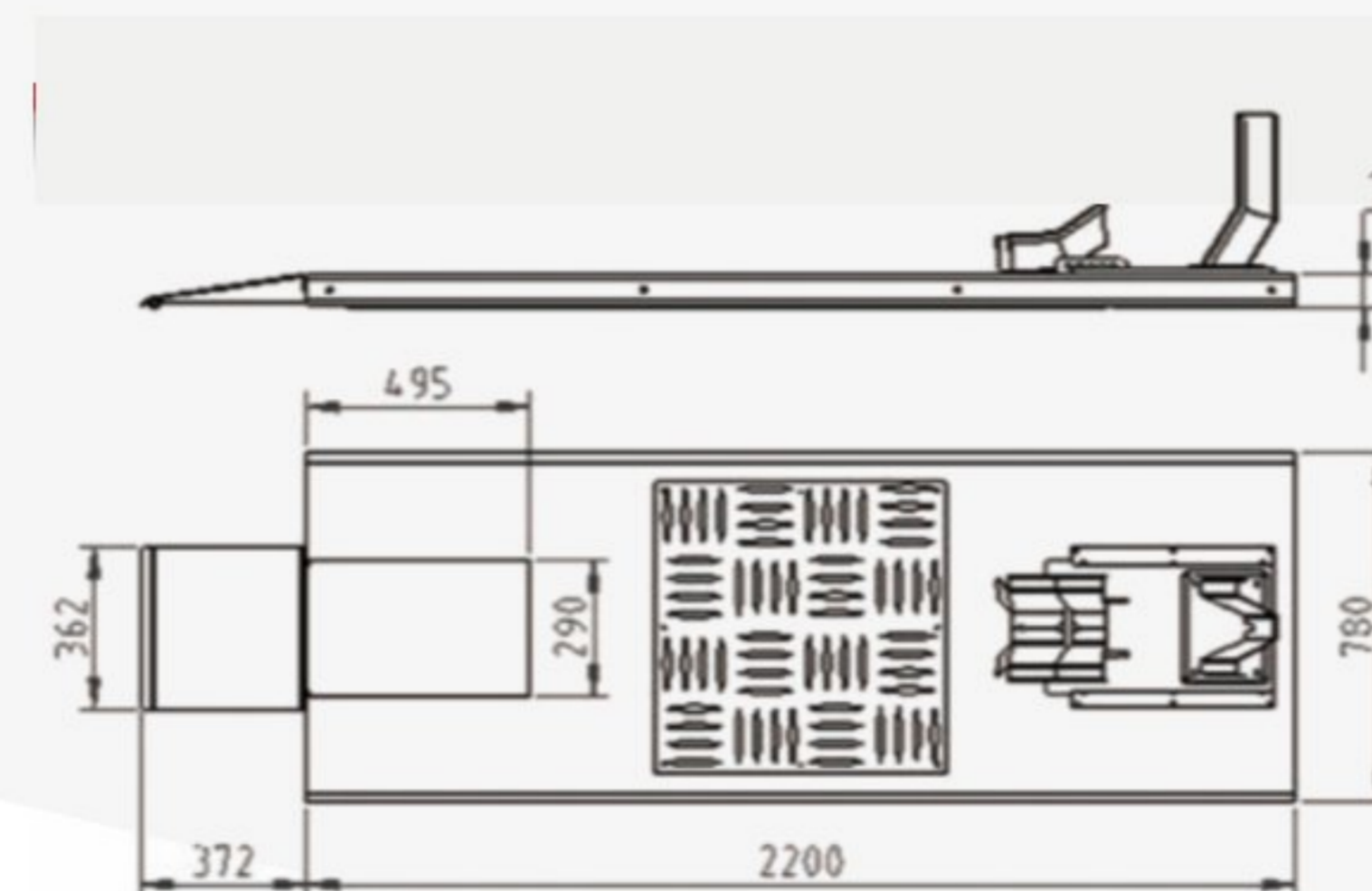

ELEVADOR HIDRÁULICO DE TIJERAS PARA MOTOCICLETAS

- Doble cilindro hidráulico.
- Garra de sujeción de rueda fabricada en Zinc.
- Plancha trasera abatible para fácil desmontaje de la rueda.
- Rampa inferior móvil y recogible.
- Ojales laterales para sujeción incluidos.

ÉLÉVATEUR HYDRAULIQUE À CISEAUX POUR MOTO

- Double cylindre hydraulique.
- Griffe de serrage de roue en zinc.
- Pliage rampe arrière pour l'enlèvement de la roue facile.
- Rampa inférieure mobile et rétractable.

HYDRAULIC SCISSOR LIFT FOR MOTORCYCLES

- Double hydraulic cylinder
- Zinc vehicle holding clamp
- Back platform for easy wheel disassembling
- Lower mobile and folding ramp





SOLLEVATORE IDRAULICO A FORBICE PER MOTOCICLETTE

- Doppio cilindro idraulico.
- Morsa di fissaggio della ruota. Prodotta in lamiera zincata.
- Lastra posteriore pieghevole per un facile smontaggio della ruota.
- Rampa inferiore mobile e pieghevole.

KN3606MT

Königstein



-  Garra de zinc
-  Griffe de serrage de roue en zinc.
-  Zinc vehicle holding clamp
-  Morsa zincata.



-  Incluido
-  Inclus
-  Included
-  Inclusi



ES: Escanee el código para más información.

FR: Scannez le code pour plus d'informations.







EN: Scan the code for further information.

IT: Scansiona il codice per maggiori informazioni.



Königstein

1.5T

-  940 mm
-  1500 kg
-  1545 mm
-  688 mm
-  12V DC / 1.8 kw
-  1540 x 936 x 685 mm
-  152 kg

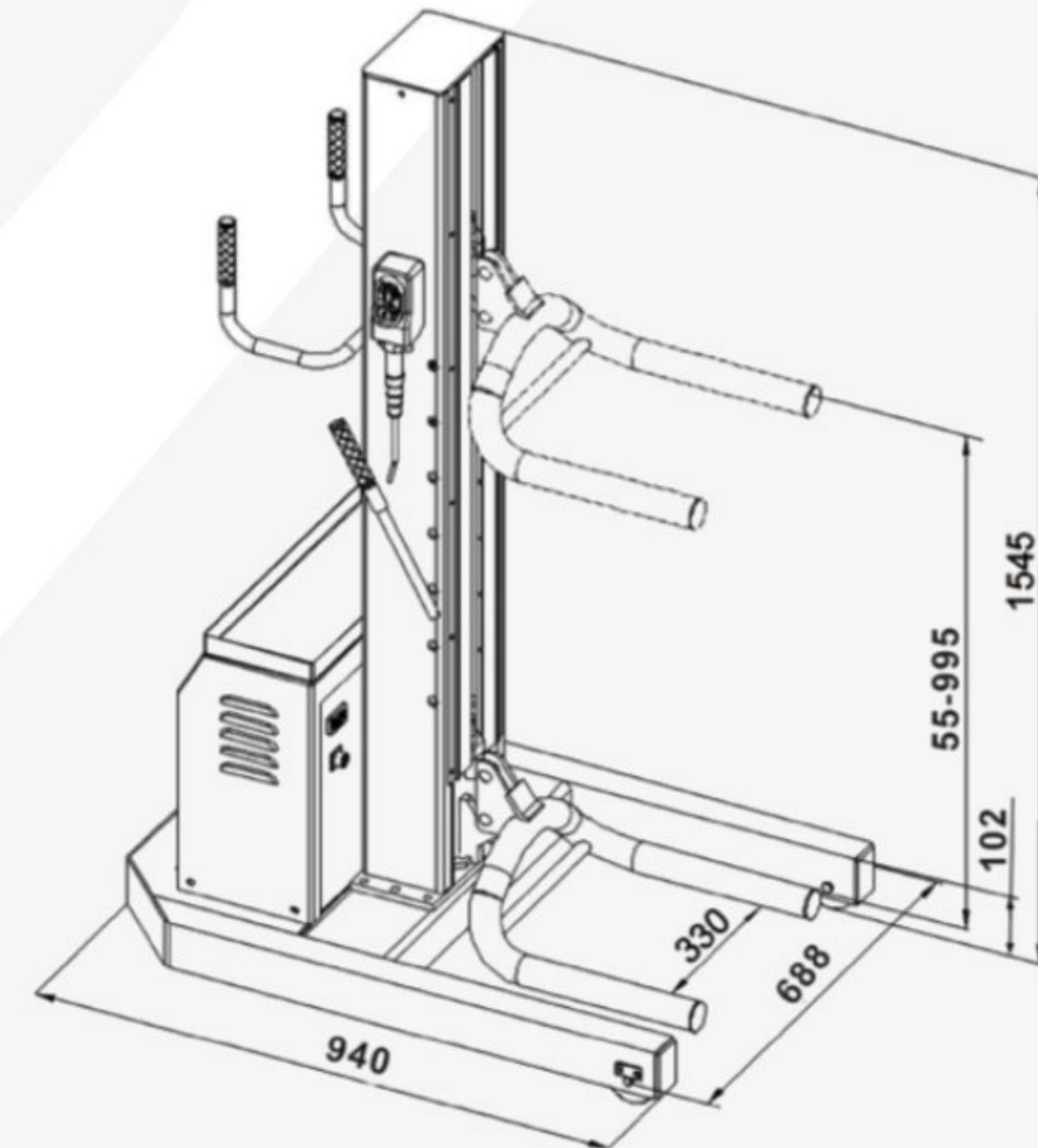

 **ELEVADOR LATERAL PORTÁTIL CON BATERÍA**

- Permite una posición ergonómica de trabajo
- Múltiples maneras de elevación para varias aplicaciones
- Ideal para vehículos de perfil bajo
- Mando de mano con base magnética

 **ÉLÉVATEUR LATÉRAL PORTABLE AVEC BATTERIE**

- Permet une position de travail ergonomique
- Plusieurs modes d'élévation pour diverses applications
- Idéal pour les véhicules à profil bas.

 **BATTERY OPERATED MOBILE SIDE LIFT**

- Good ergonomic position
- Multi-position lift
- Best for lowering profile vehicles
- Hand control with magnetic base

 **SOLLEVATORE LATERALE PORTATILE CON BATTERIA**

- Permette una posizione di lavoro ergonomica
- Diverse modalità di sollevamento per diverse applicazioni
- Ideale per veicoli a basso profilo
- Comando a mano con base magnetica

KN3115PL

Königstein



ES: Escanee el código para más información.

FR: Scannez le code pour plus d'informations.

EN: Scan the code for further information.

IT: Scansiona il codice per maggiori informazioni.



Königstein

3T



570 mm



3000 kg



1300 mm



1680 mm



1685 x 845 x 315 mm



67 kg



AVAILABLE COLORS

BLACK & RED (NOT AVAILABLE)

BLACK & LIGHT BLUE

ELEVADOR DE COCHE PORTATIL BASCULANTE Y AJUSTABLE - 3T

- Elevador portátil basculante, se puede que lo deslizar debajo del coche. Este elevador tiene ruedas para hacer un uso mas sencillo.

- Se puede elevar con un taladro eléctrico o manualmente con la herramienta que se suministra. Se puede detener en cualquier posición permitiendo inclinar el coche hacia la posición deseada.

PONT ÉLÉVATEUR DE VOITURE D'INCLINAISON - 3T

- Nous avons un nouveau élévateur d' inclinaison portable, très faible pour lui permettre de glisser sous la voiture, cet élévateur a des roues pour l' utiliser plus facilement.

- Ensuite, vous pouvez le soulever avec une perceuse électrique ou manuellement à l'aide de l'outil fourni. Vous pouvez l' arrêter dans quelque position, puis la voiture peut être verrouillé incline vers l' avant ou vers l' arrière.

TILT LIFT - 3T

- Nous avons un nouveau élévateur d' inclinaison portable, très faible pour lui permettre de glisser sous la voiture, cet élévateur a des roues pour l' utiliser plus facilement.

- Ensuite, vous pouvez le soulever avec une perceuse électrique ou manuellement à l'aide de l'outil fourni. Vous pouvez l' arrêter dans quelque position, puis la voiture peut être verrouillé incline vers l' avant ou vers l' arrière.

ASCENSORE PER AUTO INCLINABILE - 3T

- Sollevatore basculante portatile, puoi farlo scorrere sotto l'auto. Questo sollevatore è dotato di ruote per facilitarne l'utilizzo.

- Può essere sollevato con un trapano elettrico o manualmente con l'attrezzo in dotazione. Può essere fermato in qualsiasi posizione consentendo di inclinare l'auto nella posizione desiderata..

1. Borriquete 2. Soportes de caucho 3. Adaptadores 4. Soportes para pared 5. Manibela

1. Borriquete 2. Supports en caoutchouc 3. Adaptateurs 4. Supports muraux 5. Poignée

1. Borriquete 2. Rubber mounts 3. Adapters 4. Wall mounts 5. Handle

1. Borriquete 2. Supporti in gomma 3. Adattatori 4. Supporti a parete 5. Maniglia

KN3007

Königstein



1

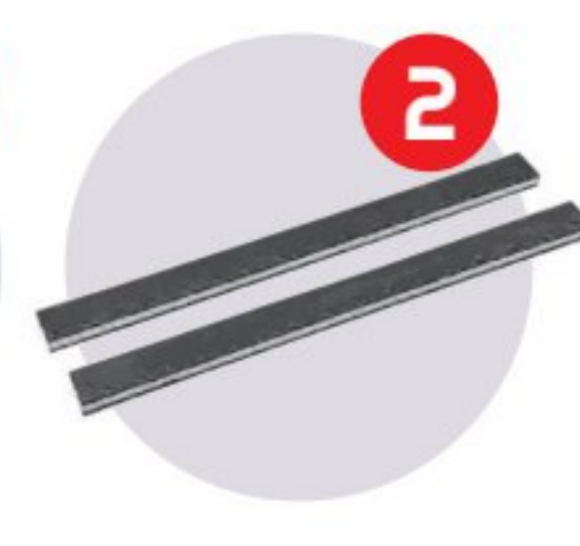

2



3



4

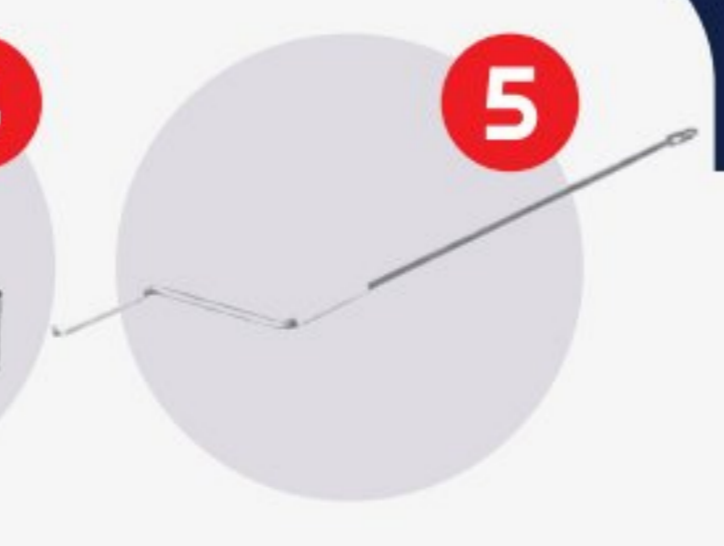

5



ES: Escanee el código para más información.

FR: Scannez le code pour plus d'informations.

EN: Scan the code for further information.

IT: Scansiona il codice per maggiori informazioni.



OPTION



Königstein

NOTA: Las imágenes mostradas tienen el propósito de representar el producto solamente y pueden variar dependiendo del modelo y stock

80KG



80KG

 **ELEVADOR DE RUEDAS**

- Mecanismo tipo gato de botella de largo alcance
- El pedal permite tener ambas manos libres para trabajar
- Cuatro ruedas giratorias (dos con freno)
- Ancho ajustable, 300 mm o 360 mm entre rodillos, brinda mayor flexibilidad

 **ÉLÉVATEUR POUR ROUES**

- Mécanisme de type cric à longue portée
- L'utilisation de la pédale laisse les deux mains libres pour travailler
- Quatre roulettes pivotantes
- Largeur réglable, 300 mm ou 360 mm entre les rouleaux, donne une plus grande flexibilité

 **HYDRAULIC WHEEL LIFT**

- Long reach bottle jack type mechanism
- Pedal operation leaves both hands free for working
- Four swivel caster (two with brakes)
- Adjustable width, 300 mm or 360 mm between roller, gives greater flexibility

 **SOLLEVATORE RUOTE**

- Meccanismo tipo martinetto a lunga portata
- L'azionamento a pedale lascia libere entrambe le mani per lavorare
- Quattro ruote girevoli (due con freno)
- La larghezza regolabile, di 300 mm o 360 mm tra i rulli, offre una maggiore flessibilità

 **CUBA DE INSPECCIÓN TÉCNICA**

- Permite detectar con facilidad los pinchazos y poros de los neumáticos.
- Accionamiento neumático con regulador de presión y decantador.
- Cilindro neumático y eje de desbloqueo.
- Tubería de drenaje y vaciado

 **RÉSERVOIR DE VÉRIFICATION**

- Permet détecter facilement les crevaisons et les pores de vos pneus.
- Commande pneumatique avec régulateur de pression et décanter.
- Cylindre pneumatique et axe de déverrouillage.
- Tuyau de drainage et de vidange.

 **TYRE DUNKER**

- Easy detecting punctures and pores in tyres.
- Pneumatic start with pressure regulator and decanter.
- Pneumatic cylinder and unlocking axe.
- Steel tank with noncorrosive coat.
- Drain and vacuum pipe.

 **SERBATOIO D'ISPEZIONE DEI PNEUMATICI**

- Permette di rilevare con facilità i fori nei pneumatici.
- Azionamento pneumatico con regolatore di Pressione.
- Cilindro pneumatico e albero di sblocco.
- Serbatoio in acciaio con trattamento e vernice anti-corrosiva.
- Tubi di drenaggio e svuotamento.



80E0ENY



QR

ES: Escanee el código para más información.

EN: Scan the code for further information.

FR: Scannez le code pour plus d'informations.

IT: Scansiona il codice per maggiori informazioni.



QR

ES: Escanee el código para más información.

EN: Scan the code for further information.

FR: Scannez le code pour plus d'informations.

IT: Scansiona il codice per maggiori informazioni.



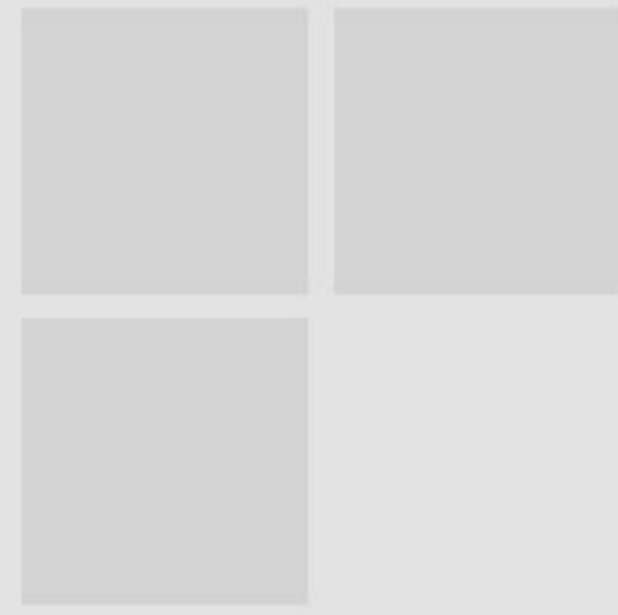

INDUSTRIAL

 **Königstein**
konigstein.es



7.5T

9.5T

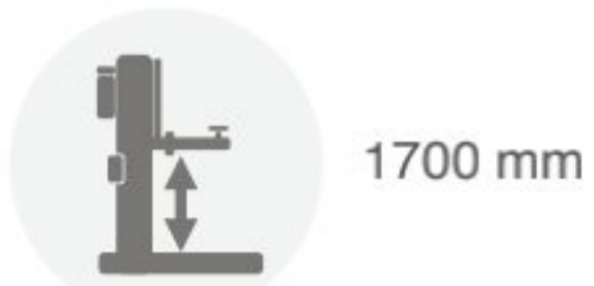

1700 mm

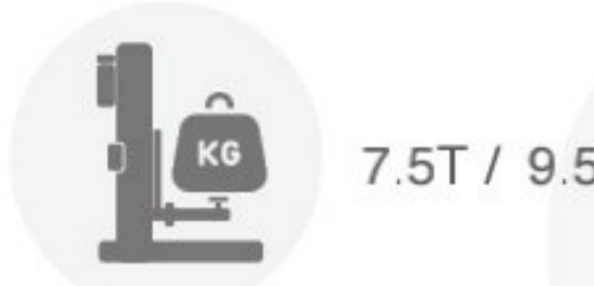

7.5T / 9.5T



2250 mm



1120 mm

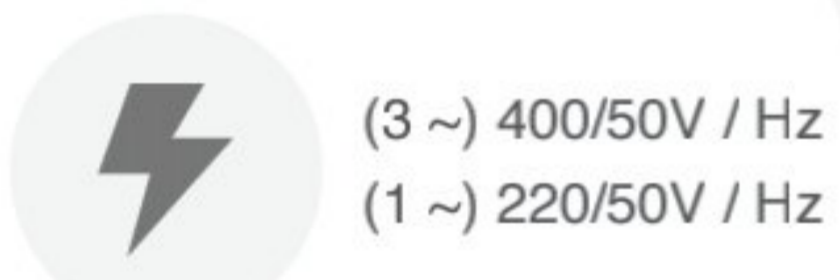

(3 ~) 400/50V / Hz
(1 ~) 220/50V / Hz

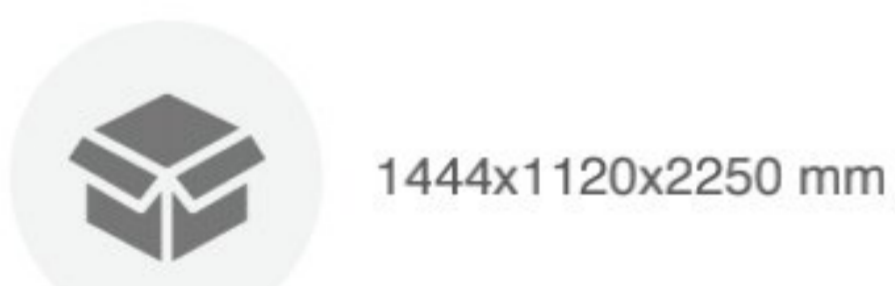

1444x1120x2250 mm



700 kg/u

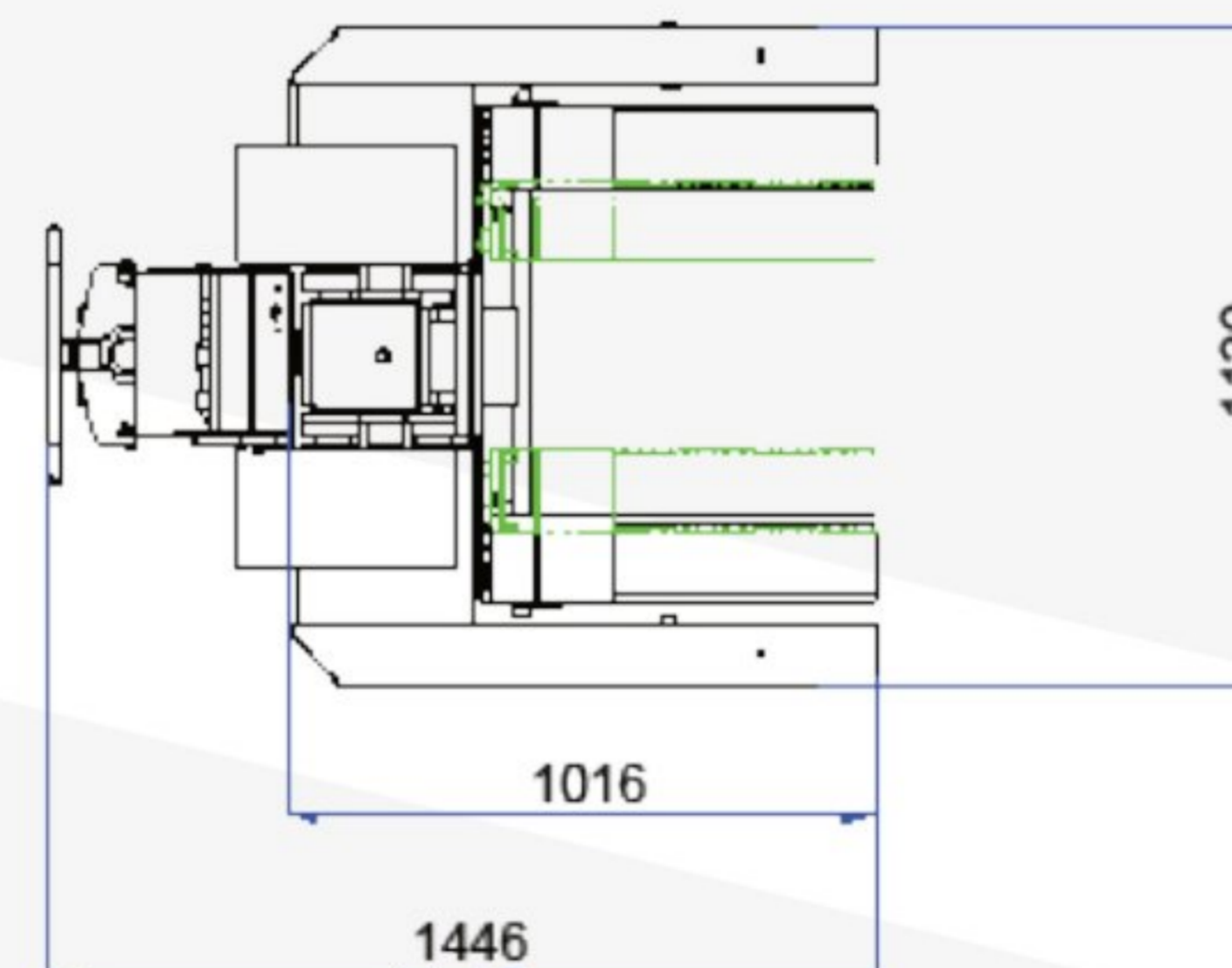
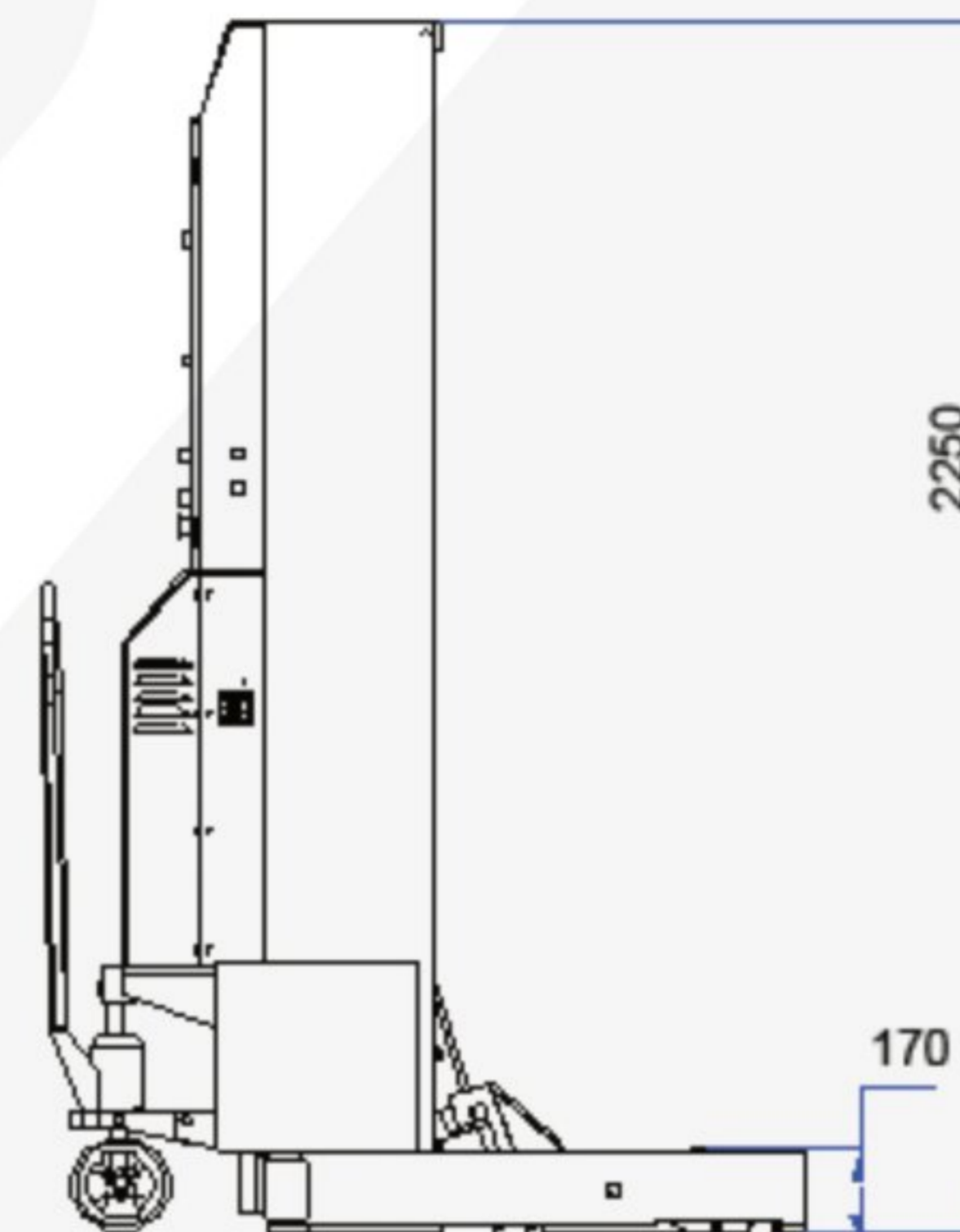

COLUMNAS MÓVILES PARA VEHÍCULOS INDUSTRIALES 7.5 Y 9T (VERSIONES CABLE O WIRELESS)

Funcionamiento simultáneo de todas las columnas

Pantalla LCD muestra la altura de elevación exacta de cada columna

Doble seguridad garantizada tanto por el control de flujo hidráulico y cerraduras mecánicas



COLONNA MOBILE PER VEICOLI INDUSTRIALI - 7.5T - 9T - VERSIONI: VIA CAVO O WIRELESS

Fonctionnement simultané de toutes les colonnes

L'écran LCD affiche la hauteur actuelle de chaque colonne

Double sécurité garantie à la fois par le contrôle hydraulique du débit et les serrures mécaniques



INDUSTRIAL MOBILE POST LIFT 7.5 - 9T CABLE / WIRELES

Simultaneous operation of all columns

LCD shows the current height of each column

Double security guaranteed by both the hydraulic flow control and mechanical locks



COLONNA MOBILE PER VEICOLI INDUSTRIALI - 7.5T - 9T - VERSIONI: VIA CAVO O WIRELESS

Funzionamento simultaneo di tutte le colonne

Il display LCD mostra l'esatta altezza di sollevamento di ogni colonna

Doppia sicurezza garantita dal controllo del flusso idraulico e dalle chiusure meccaniche

KN3875H / 95H



ES: Escanee el código para más información.

FR: Scannez le code pour plus d'informations.







EN: Scan the code for further information.

IT: Scansiona il codice per maggiori informazioni.



NOTA: Las imágenes mostradas tienen el propósito de representar el producto solamente y pueden variar dependiendo del modelo y stock

6T

-  2023-2205 mm
-  6000 kg
-  4697-4392 mm
-  3841 mm
-  2,2 kw
-  (3 ~) 400/50V / Hz
(1 ~) 220/50V / Hz
-  0.65 x 3.15 x 1.1 m



KG 1100 kg

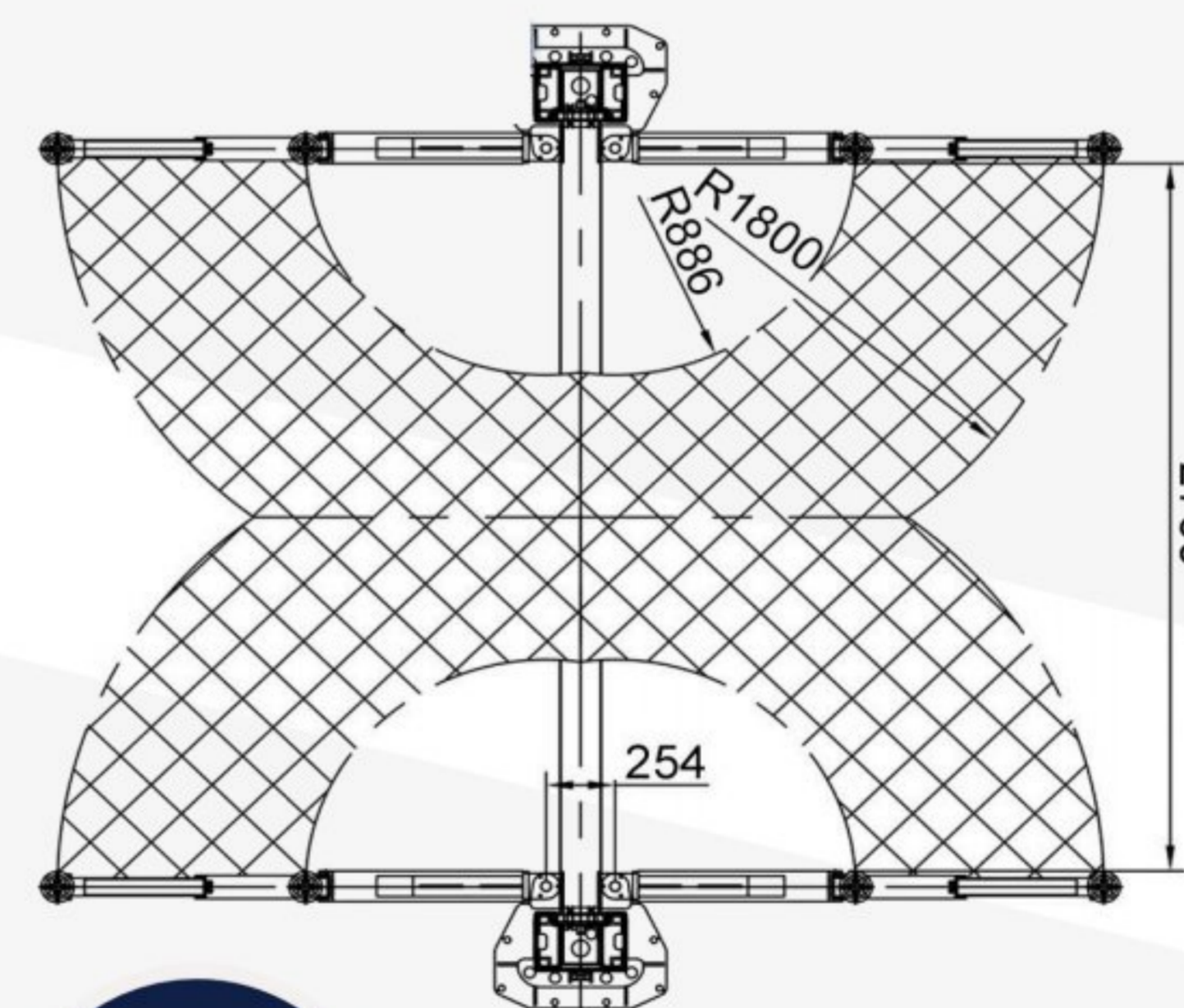
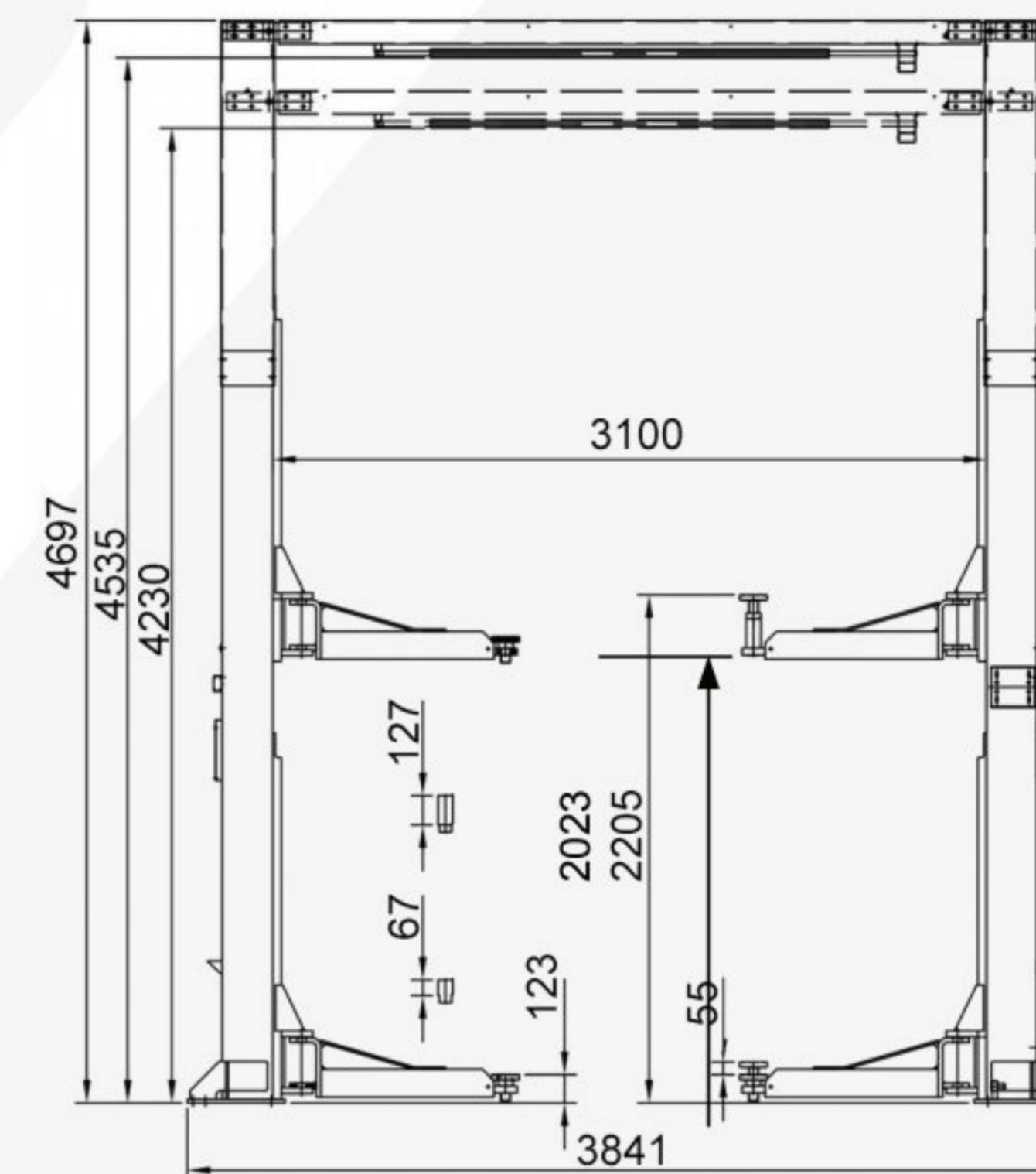

ELEVADOR DE 2 COLUMNAS INDUSTRIAL DE 6000 KILOS (6T) DE CAPACIDAD

- Elevador ajustable en altura
- 6T de capacidad de carga
- Ideal para vehículos industriales, camiones, furgonetas
- Máxima seguridad, bloqueo mecánico para prevenir descensos accidentales.

PONT ÉLÉVATEUR 2 COLONNES POUR VÉHICULES INDUSTRIELS. 6T

- Elévateur réglable en hauteur 6T de capacité de charge
- Idéal pour les véhicules industriels, camions, fourgonnettes
- Sécurité maximale, verrouillage mécanique pour éviter toute descente accidentelle.

2 POST LIFT FOR INDUSTRIAL VEHICLES

- Height adjustable lift.
- 6T lifting capacity.
- Best for industrial vehicles, lorries and vans.
- Max. Security. Mechanic lock to prevent accidents .

SOLLEVATORE 2 COLONNE PER VEICOLI INDUSTRIALI

- Sollevatore regolabile in altezza
- 6T di capacità di carico
- Ideale per veicoli industriali, camion, furgoni
- Massima sicurezza, blocco meccanico per impedire delle discese accidentali.

KN3260PSX

Königstein



ES: Escanee el código para más información.

FR: Scannez le code pour plus d'informations.

EN: Scan the code for further information.

IT: Scansiona il codice per maggiori informazioni.



Königstein

-  14" - 26"
-  1600 mm
-  780 mm
-  2500 kg
-  1.5kw
-  (1~) 220V
(3~) 380V
-  2030 x 1580 x 1000 mm

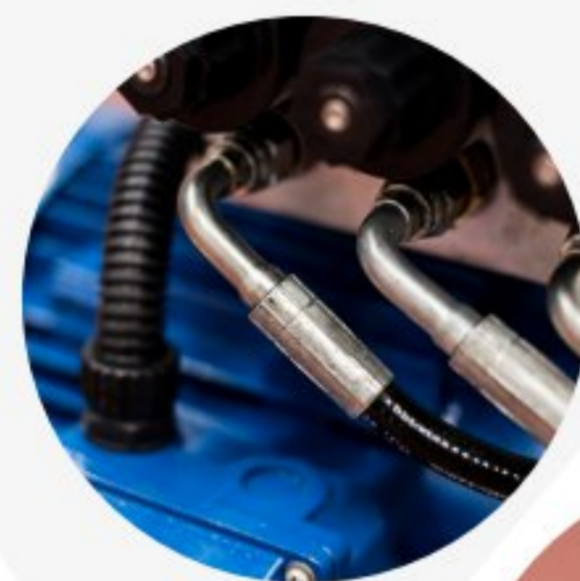

DESMONTADORA INDUSTRIAL SEMIAUTOMÁTICA PARA RUEDAS DE CAMIÓN Y AUTOBUS 14" - 26"

- Desmontadoras de ruedas electro-hidráulicas para ruedas de camión, bus, tractor etc., con diámetro de llanta comprendido entre 14" y 26".
- Todo el sistema hidráulico esta montado sobre el chasis del equipo, con esto conseguimos menos roturas, mayor eficiencia del equipo y una maquina mas compacta.
- Brazo porta-útil con movimiento giratorio semi-automático fabricado en acero laminado en frío y diseñado para un uso sencillo y cómodo
- Bloqueo de la llanta por medio de 4 garras de sujeción autocentrantes, que permiten montar ruedas desde 14" a 26"

DÉMONTÉ-PNEU INDUSTRIEL SEMI-AUTOMATIQUE POUR ROUES DE CAMIONS ET D'AUTOBUS 14" - 26"

- Démonté-pneus électro-hydrauliques pour roues de camions, bus, tracteur, etc... avec un diamètre de jante compris entre 14" et 26".
- Le dispositif hydraulique est entièrement monté sur le châssis de l'équipement, ce qui réduit les ruptures, augmente l'efficacité de l'équipement et permet de disposer d'une machine plus compacte.
- Bras porte-outils rotatif semi-automatique en acier laminé à froid, conçu pour une utilisation simple et confortable.
- Blocage de la jante au moyen de 4 mâchoires de serrage auto-centrantes, permettant de monter des roues de 14" à 26"

DESMONTADORA INDUSTRIAL SEMIAUTOMÁTICA PARA RUEDAS DE CAMIÓN Y AUTOBUS 14" - 26"

- Electro-hydraulic tyre changer for bus, lorry, tractor ,etc wheel range 14" y 26".
- All the hydraulic system is mounted on the chassis of the equipment, with this we achieve less breakage, better equipment efficiency and a more compact machine.
- Tool-holder arm with semi-automatic rotating movement made of cold rolled steel and designed for easy and comfortable use
- 4 self-centering holding claws for wheel locking.
- Wheel range 14" a 26".

DÉMONTÉ-PNEU INDUSTRIEL SEMI-AUTOMATIQUE POUR ROUES DE CAMIONS ET D'AUTOBUS 14" - 26"

- Smontagomme elettro-idraulici per ruote di camion, bus, trattori etc., con diametro del pneumatico compreso tra 14" e 26".
- Tutto il sistema idraulico è montato sul telaio dell'attrezzatura, in modo che ci siano meno fratture, maggior efficienza e una macchina più compatta.
- Braccio porta-utile che utilizza un movimento rotante automatico. È prodotto in acciaio laminato a freddo ed è progettato per un uso semplice e comodo.
- Blocco del pneumatico per mezzo di 4 morse di fissaggio autocentranti, che permettono montare ruote da 14" a 26"

KN131

Königstein



-  Incluido
-  Inclus
-  Included
-  Inclusi

 470 kg



ES: Escanee el código para más información.

FR: Scannez le code pour plus d'informations.

EN: Scan the code for further information.

IT: Scansiona il codice per maggiori informazioni.



Königstein

-  14" - 56"
-  2500 mm
-  1200 mm
-  2500 kg
-  2.4 / 3.0 kw
-  (1~) 220V
(3~) 380V
-  2310 x 2100 x 1100 mm

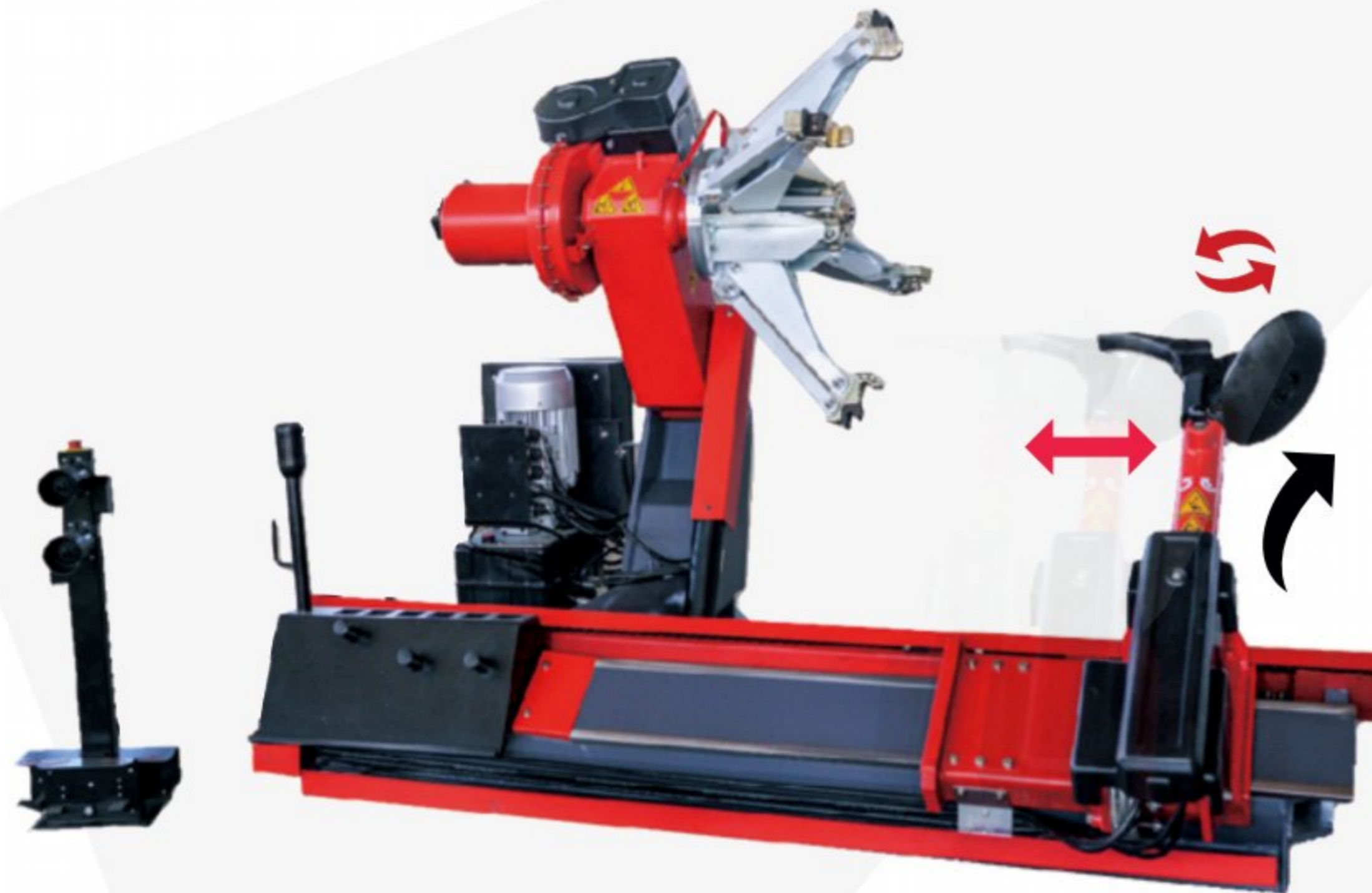

DESMONTADORA INDUSTRIAL AUTOMÁTICA PARA RUEDAS DE CAMIÓN Y TRACTOR 14" - 56"

- Todos los movimientos son automáticos y en todas las direcciones
- Equipada con cabezal bidireccional y posicionamiento hidráulico del brazo porta-útil, con disco destalonador de perfil convexo montado sobre casquillos autolubricantes.
- Todo el sistema hidráulico esta montado sobre el chasis del equipo, con esto conseguimos menos roturas, mayor eficiencia del equipo y una maquina mas compacta.
- Brazo porta-útil con movimiento giratorio automático fabricado en acero laminado en frío y diseñado para un uso sencillo y cómodo

DÉMONTE-PNEU INDUSTRIEL AUTOMATIQUE POUR ROUES DE CAMIONS ET TRACTEURS 14" - 56"

- Equipé d'une tête bidirectionnelle et d'un positionnement hydraulique du bras porte-outils, avec détalonneur à profil convexe monté sur des paliers autolubrifiants.
- Le dispositif hydraulique est entièrement monté sur le châssis de l'équipement, ce qui réduit les ruptures, augmente l'efficacité de l'équipement et permet de disposer d'une machine plus compacte.
- Bras porte-outils rotatif semi-automatique en acier laminé à froid, conçu pour une utilisation simple et confortable.
- Blocage de la jante au moyen de 4 mâchoires de serrage auto-centrantes, permettant de monter des roues de 14" à 56".

AUTOMATIC INDUSTRIAL TYRE CHANGER FOR TRUCK AND TRACTOR 14" - 56"

- Equipped with a bidirectional head and hydraulic positioning of the tool-holder arm, with a convex profile bead breaker disc mounted on self-lubricating bushings.
- All the hydraulic system is mounted on the chassis of the equipment, with this we achieve less breakage, better equipment efficiency and a more compact machine.
- Tool-holder arm with semi-automatic rotating movement made of cold rolled steel and designed for easy and comfortable use
- 4 self-centering holding claws for wheel locking.
- Wheel range 14" a 56"

SMONTAGOMME INDUSTRIALE AUTOMATICO PER RUOTE DI CAMION E TRATTORI 14" - 56"

- Dotato di testina bidirezionale e posizionamento idraulico del braccio porta-utile, con un disco smontagomme di profilo convesso montato su cappucci autolubrificanti.
- Tutto il sistema idraulico è montato sul telaio dell'attrezzatura, in modo che ci siano meno rotture, maggior efficienza e una macchina più compatta.
- Braccio porta-utile che utilizza un movimento rotante automatico. È prodotto in acciaio laminato a freddo ed è progettato per un uso semplice e comodo
- Blocco del pneumatico per mezzo di 4 morse di fissaggio autocentranti, che permettono montare ruote da 14" a 56"



-  Incluido
-  Inclus
-  Included
-  Inclusi

 1300 kg



ES: Escanee el código para más información.

EN: Scan the code for further information.

FR: Scannez le code pour plus d'informations.

IT: Scansiona il codice per maggiori informazioni.



 **EQUILIBRADORA DE RUEDAS INDUSTRIAL**

- Equilibradora motorizada para ruedas de camión, autobuses, vehículos comerciales ligeros y turismos, con un peso máximo de 160 kg y 1.200mm de altura con sistema de medición electrónico y display.
- Un programa para equilibrado estático y cuatro programas para equilibrado dinámico.
- Panel con displays luminoso de gran tamaño.
- Visualización del desequilibrio después de un solo lanzamiento con escamoteo del residuo inferior a 5 grs. para ruedas de turismo y de 50 grs. para las de camión; no obstante puede reducirse a 1 gr. si se desea.
- Visualización de la corrección del desequilibrio estático.

 **EQUILIBREUSES DE ROUES INDUSTRIEL**







- Equilibreuse motorisée pour roues de camions, d'autobus, de véhicules utilitaires légers et de voitures de tourisme, avec un poids maximum de 160 kg et une hauteur de 1 200 mm, avec système de mesure et d'affichage électroniques.
- Un programme pour l'équilibrage statique et quatre programmes pour l'équilibrage dynamique.
- Tableau avec de grand afficheurs éclairés.
- Visualisation du déséquilibre après une seule lancée de mesure, avec une tolérance inférieure à 5 gr pour les roues de voiture et à 50 gr pour les roues de camion, mais qui peut être réduite à 1 gr.
- Affichage de la correction du déséquilibre statique.

 **INDUSTRIAL WHEEL BALANCER"**

- Motorized balancer for truck, bus, light commercial vehicle and passenger car wheels, with a maximum weight of 160 kg and 1,200mm height with electronic measurement system and display.
- One static balancer program and 4 balancer programs.
- Built in pneumatic lift to fit the wheel in the axle easily and work confortly
- Big size display.
- Imbalance view after a single toss with a residue of less than 5gr. for tourism wheels, and 50 grs. for trucks; however it can be reduced to 1 gr. if desired.
- Illustrates wrong static imbalance.

 **EQUILIBRATRICE INDUSTRIALE**

- Equilibratrice motorizzata per ruote di camion, autobus, veicoli commerciali leggeri e automobili, con un peso massimo di 160 kg e 1.200mm di altezza con sistema di misurazione elettronica e display.
- Un programma per bilanciamento statico e quattro programmi per il bilanciamento dinamico.
- Pannello con display luminosi di grandi dimensioni.
- Visualizzazione dello squilibrio dopo una sola attivazione con comparsa del residuo inferiore a 5 grs. per ruote di automobili e di 50 grs. per quelle dei camion; nonostante ciò, se si desidera si può ridurre a 1 gr.
- Visualizzazione della correzione dello squilibrio statico.

-  12" - 24"
-  1200 mm
-  5.5 - 20"
-  0.25kw
-  (1 ~) 220V
-  ...
-  320 kg



KN250

Königstein



-  Incluido
-  Inclus
-  Included
-  Inclusi

 1300 kg



ES: Escanee el código para más información.

FR: Scannez le code pour plus d'informations.

EN: Scan the code for further information.

IT: Scansiona il codice per maggiori informazioni.



Königstein



A series of horizontal dashed lines for writing, arranged in two columns. The lines are evenly spaced and extend across most of the page width.



A large writing area consisting of multiple horizontal dashed lines across the page, intended for text entry.



Distribuciones Eviran SL | © 2022 | +34 954 680 870 | pedidos@eviran.es
PI La Palmera C/ Dátiles, 7 41703 Dos Hermanas - Seville - Spain



Königstein
konigstein.es

Distribuciones Eviran SL | © 2022 | +34 954 680 870 | pedidos@eviran.es PI La Palmera C/ Dátiles, 7 41703 Dos Hermanas - Seville - Spain